

May.1.2023 Copyright 2023 HIROSE ELECTRIC CO., LTD. All Rights Reserved.  
In case of consideration for using Automotive equipment / device which demand high reliability, kindly contact our sales window correspondents.

COUNT	DESCRIPTION OF REVISIONS	BY	CHKD	DATE	COUNT	DESCRIPTION OF REVISIONS	BY	CHKD	DATE

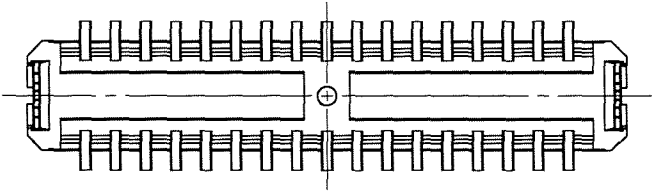
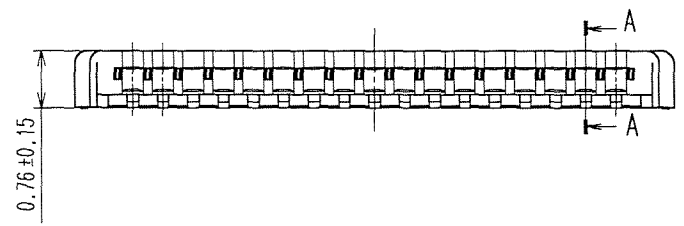
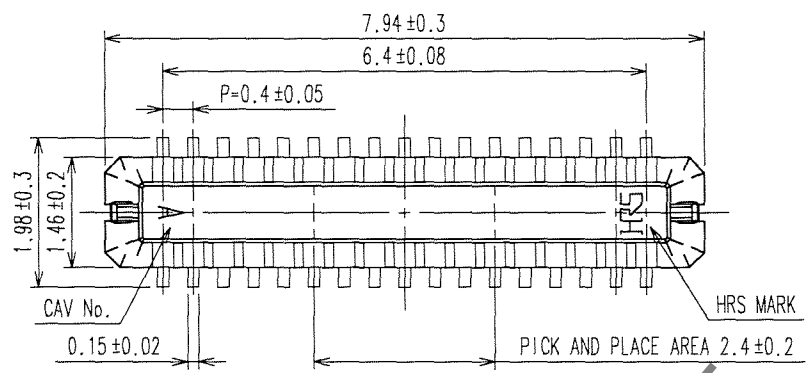

HRS DRAWING FOR REFERENCE

RECOMMENDED METAL MASK  
OPENING PATTERN

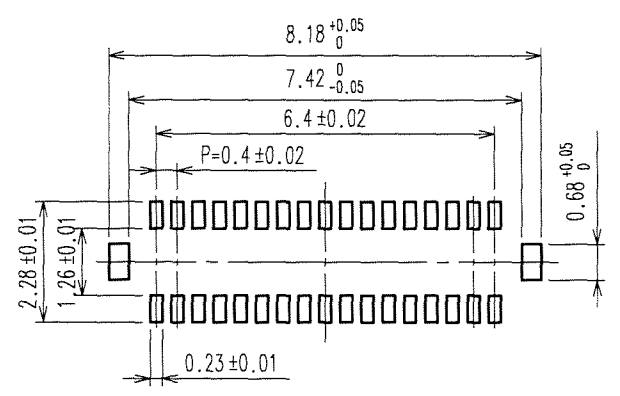

RECOMMENDED SOLDER PASTE: THICKNESS 120μm

RECOMMENDED PATTERN

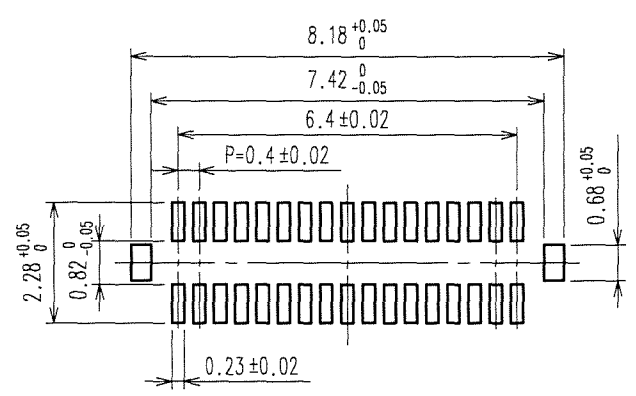

ENGAGEMENT FIGURE

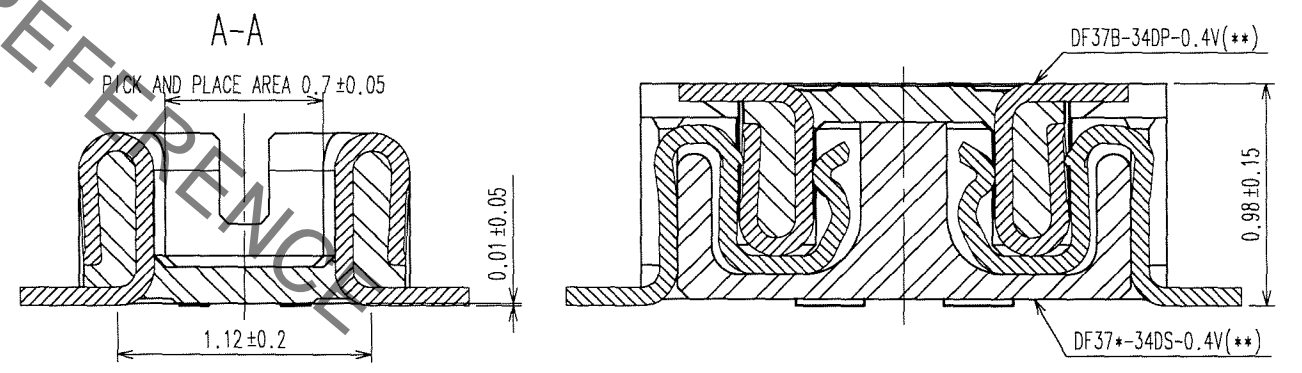

- NOTE 1. ALL LEADS CO-PLANARITY SHALL BE 0.1 MAX.  
 2. PER REEL : 8000 CONNECTORS.  
 3. AT THE BEGINNING OF THE REEL, 100 mm AT MIN SHALL BE EMPTY POCKETS.  
 AT THE END OF THE REEL, 160 mm AT MIN SHALL BE EMPTY.  
 4. CONTACT PLATING SPECIFICATIONS.  
 CONTACT AREA : GOLD 0.05μm MIN.  
 SMT LEAD : GOLD 0.05μm MIN.  
 UNDERPLATING : NICKEL 1μm MIN.  
 (SURFACE : SEALING)  
 5. METAL HOLD DOWN PLATING SPECIFICATIONS.  
 MOUNTING AREA: GOLD 0.05μm MIN.  
 UNDERPLATING : NICKEL 1μm MIN.  
 6. PEEL FORCE REFERS TO JIS C 0806.

TO

3	PHOSPHOR BRONZE	5	6	PS	PLASTIC REEL (BLACK)	
2	PHOSPHOR BRONZE	4	5	POLYESTER	CLEAR (COVER TAPE)	
1	LCP	UL94V-0, BLACK	4	PS	CLEAR (EMBOSSED CARRIER TAPE)	
NO.	MATERIAL	FINISH, REMARKS	NO.	MATERIAL	FINISH, REMARKS	
CODE NO. (OLD)		DRAWN	DESIGNED	CHECKED	APPROVED	RELEASED
		J. Oai	J. Oai	K. Ikeda	K. Ikeda	
		67.03.29	67.03.29	67.03.29	67.03.29	
DRAWING NO. EDC3-31554-01			PART NO. DF37B-34DP-0.4V(51)			
SCALE FREE			CODE NO. CL684-3064-2-51			
UNITS mm			HRS HIROSE ELECTRIC CO., LTD			

May.1.2023 Copyright 2023 HIROSE ELECTRIC CO., LTD. All Rights Reserved.  
In case of consideration for using Automotive equipment / device which demand high reliability, kindly contact our sales window correspondents.

COUNT	DESCRIPTION OF REVISIONS	BY	CHKD	DATE	COUNT	DESCRIPTION OF REVISIONS	BY	CHKD	DATE

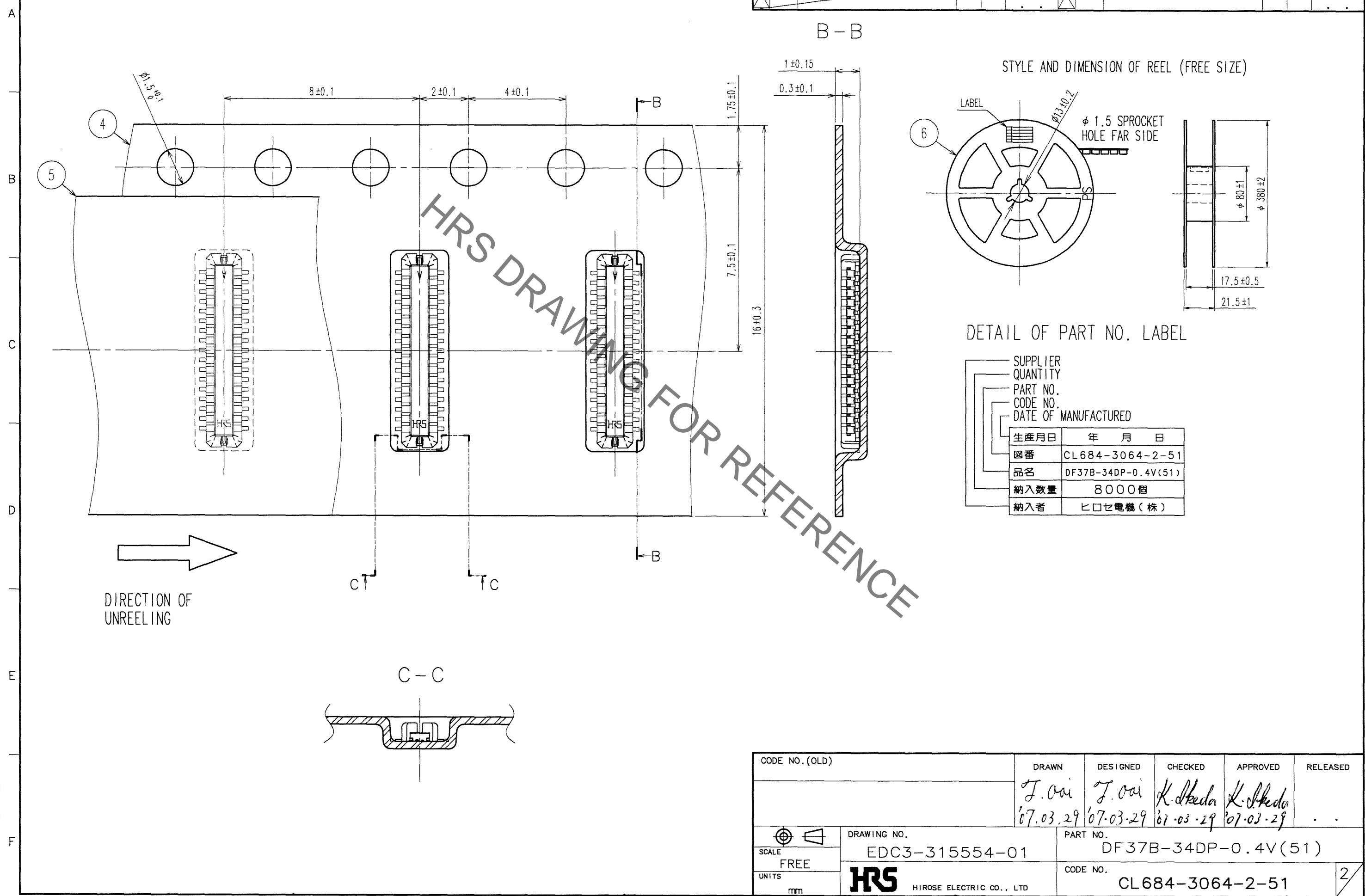

STYLE AND DIMENSION OF REEL (FREE SIZE)

DETAIL OF PART NO. LABEL

SUPPLIER	
QUANTITY	
PART NO.	
CODE NO.	
DATE OF MANUFACTURED	
生産月日	年 月 日
図番	CL684-3064-2-51
品名	DF37B-34DP-0.4V(51)
納入数量	8000個
納入者	ヒロセ電機(株)

CODE NO. (OLD)	DRAWN	DESIGNED	CHECKED	APPROVED	RELEASED
	J. Oai	J. Oai	K. Ikeda	K. Ikeda	
	07.03.29	07.03.29	07.03.29	07.03.29	
SCALE	DRAWING NO.		PART NO.		
FREE	EDC3-315554-01		DF37B-34DP-0.4V(51)		
UNITS	HIROSE ELECTRIC CO., LTD		CODE NO.		
mm			CL684-3064-2-51		

TO