



PCE Americas Inc.
711 Commerce Way
Suite 8
Jupiter
FL-33458
USA
From outside US: +1
Tel: (561) 320-9162
Fax: (561) 320-9176
info@pce-americas.com

PCE Instruments UK Ltd.
Units 12/13
Southpoint Business Park
Ensign way
Hampshire / Southampton
United Kingdom, SO31 4RF
From outside UK: +44
Tel: (0) 2380 98703 0
Fax: (0) 2380 98703 9
info@pce-instruments.com

www.pce-instruments.com/english
www.pce-instruments.com

Manual

Accelerometer

PCE-VT 204

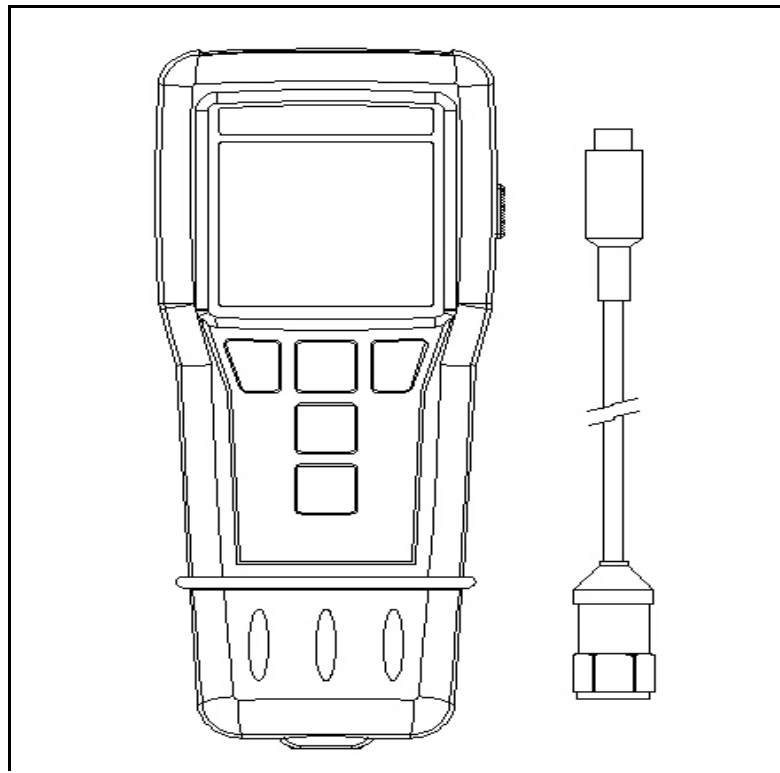

TABLE OF CONTENTS

| | | |
|------|---|----|
| 1 | FEATURES..... | 1 |
| 2 | SPECIFICATIONS..... | 3 |
| 3 | FRONT PANEL DESCRIPTION..... | 7 |
| 3-1 | Display..... | 7 |
| 3-2 | Power button (vibration)..... | 7 |
| 3-3 | Hold/ESC/Zero button..... | 7 |
| 3-4 | Eenter/REC button..... | 7 |
| 3-5 | Function/Send button..... | 7 |
| 3-6 | Unit/Logger button..... | 7 |
| 3-7 | Operation button (tachometer)..... | 7 |
| 3-8 | Surface speed wheel (contact tach.)..... | 7 |
| 3-9 | RPM adapter (contact tach.)..... | 7 |
| 3-10 | Protection cover (contact tach.)..... | 7 |
| 3-11 | Screw for protection cover..... | 7 |
| 3-12 | Cable plug (vibration sensor)..... | 7 |
| 3-13 | Vibration sensor..... | 7 |
| 3-14 | Magnetic base..... | 7 |
| 3-15 | Input socket (vibration sensor)..... | 7 |
| 3-16 | Laser light beam (photo tach.)..... | 7 |
| 3-17 | Photo tach. detecting sensor..... | 7 |
| 3-18 | IR probe input socket..... | 7 |
| 3-19 | RS-232 output terminal..... | 7 |
| 3-20 | Battery cover/battery compartment..... | 7 |
| 3-21 | Cone rubber (RPM adapter)..... | 7 |
| 3-22 | Funnel rubber (RPM adapter)..... | 7 |
| 4 | VIBRATION MEASURING PROCEDURE..... | 9 |
| 5 | TACHOMETER MEASURING PROCEDURE..... | 20 |
| 6 | IR TEMP. MEASURING PROCEDURE..... | 24 |
| 7 | RS232 PC SERIAL INTERFACE..... | 24 |
| 8 | BATTERY REPLACEMENT..... | 26 |
| 9 | OPTIONAL ACCESSORIES..... | 26 |
| 10 | CLASSIFICATION RANGES (Vibration)..... | 27 |
| 11 | SENSITIVITY RELATIVE TABLE ACCORDING ISO 2954 (Vibration)..... | 28 |

1. FEATURES

Vibration function :

- * Applications for industrial vibration monitoring :
All industrial machinery vibrates. The level of vibration is a useful guide to machine condition. Poor balance, misalignment & looseness of the structure will cause the vibration level increase, it is a sure sign that the maintenance is needed.
- * Acceleration range : 200 m/s².
- * Velocity range : 200 mm/s.
- * Displacement (p-p) range : 2 mm.
- * Metric and imperial display unit .
- * RMS measurement for Acceleration and Velocity.
- * Peak to peak measurement for Displacement.
- * Peak function for Acceleration and Velocity.
- * Max. hold function for Acceleration (peak), Velocity (peak) and Displacement (peak to peak).
- * Frequency range 10 Hz - 1 kHz, sensitivity relative meet ISO 2954.
- * Zero function, executed by front buttons.
- * Data logger function with flexible sampling time selection, can save max. 1000-point data into the memory circuit.
- * Data hold button to freeze the desired reading.
- * Memory function to record maximum and minimum reading of RMS value (Acc., Vel.) or Displacement (p-p).
- * Auto shut off saves battery life.
- * Professional vibration meter supply with separate vibration sensor & magnetic base, full set.

Tachometer (photo, contact) function :

- * Laser light detecting source, long measuring range up to 1.5 meters, it is useful in the RPM measurement application where the machine would be a risk to the operator or close access is difficult or not possible.
- * The best Tachometer in the world. 2 in 1, one instrument combine Photo Tachometer & Contact Tachometer.
- * Wide measuring range from 0.5 to 100,000 RPM, 0.1 RPM resolution for the measured value < 1000 RPM.
- * Microprocessor based circuit, crystal time base, high precision with 0.05% accuracy.
- * Memory with recall function, the last value, max., value, min. value will be stored into the memory automatically.
- * Patent patented.

General function :

- * Super large LCD display.
- * No contact infrared temperature measurement via optional IR temp. probe.
- * RS 232 computer interface.
- * Optional data acquisition software and data logger software.
- * Microcomputer circuit, high performance.
- * Built-in low battery indicator.
- * Heavy duty & compact housing case.
- * Complete set with the hard carrying case.

2. SPECIFICATIONS

2-1 Vibration function

| | | |
|---|--|--------------------------------|
| Velocity range | 0.5 to 199.9 mm/s | |
| | 0.05 to 19.99 cm/s | |
| | 0.02 to 7.87 in/s | |
| Acceleration range | 0.5 to 199.9 m/s ² | |
| | 0.05 to 20.39 g | |
| | 2 to 656 ft/s ² | |
| Displacement (p-p) <i>* p-p : Peak to Peak</i> | 0.005 to 1.999 mm | |
| | 0.002 to 0.078 inch | |
| Frequency range | 10 Hz to 1 KHz <i>* Sensitivity relative during the the frequency range meet ISO 2954 Refer to table 1, page 28.</i> | |
| Function | Velocity | RMS, Peak, Max. hold (peak). |
| | Acceleration | RMS, Peak, Max. hold (peak). |
| | Displacement | p-p, Max. hold (p-p). |
| | <i>* Peak : To measure the peak value. * p-p : Peak to peak value. * Max. hold : To hold the max. peak or p-p value.</i> | |
| Accuracy | ± (5 % + 2 d) reading , 160 Hz, 80 Hz. <i>* 23 ± 5 °C</i> | |
| Calibration point | Velocity | 50 mm/s (160 Hz) |
| | Acceleration | 50 m/s ² (160 Hz) |
| | Displacement (p-p) | 0.05 mm (160 Hz) |
| Data hold | Freeze the desired reading. | |

| | | |
|------------------------------|--|---|
| Memory | Maximum & Minimum value. * <i>Memory function are only available for RMS (Acc., Vel.) and Displacement (p-p).</i> | |
| Sampling time | Approx. 1 second. | |
| Data logger | Data logger function with flexible sampling time selection, can save max. 1000-point data into the memory circuit. | |
| Sampling Time of Data Logger | Manual | Push the data logger button once will save the data one time. |
| | Auto | 1, 2, 10, 30, 60, 600, 1800, 3600 seconds. |
| Sampling time | Approx. 1 second. | |
| Power off | Auto shut off, saves battery life, or manual off by push button. | |

2-2 Tachometer (photo, contact) function

| | | |
|------------|--|----------------------|
| Range | Photo Tachometer : 10 to 99,999 RPM | |
| | Contact Tachometer : 0.5 to 19,999 RPM | |
| | Surface Speed (m/min.) : 0.05 to 1,999.9 m/min. | |
| | Surface Speed (ft/min.) : 0.2 to 6,560 ft/min. | |
| Accuracy | $\pm (0.05 \% + 1 \text{ digit })$. | |
| Resolution | 0.1 RPM | < 1,000 RPM |
| | 1 RPM | $\geq 1,000$ RPM |
| | 0.01 m/min. | < 100 m/min. |
| | 0.1 m/min. | ≥ 100 m/min. |
| | 0.1 ft/min. | < 1000 ft/min. |
| | 1 ft/min. | $\geq 1,000$ ft/min. |
| Time base | Quartz crystal | |

| | |
|--|--|
| Sampling Time | Photo Tachometer - 1 sec. (≥ 60 RPM). Contact Tachometer - 1 sec. (≥ 6 RPM). |
| Photo Tachometer detecting distance | 50 - 1,500 mm typically. <i>* Spec. of detecting distance are that under the size of reflecting tape is 10 mm square & the measuring RPM value is 1,800 PPM. The max. & min. detecting distance may change under different environment, different reflecting tape or the measuring RPM beyond 1800 RPM.</i> |
| Laser light source <i>* Photo Tach.</i> | * Less than 1 mW. * Class 2 laser diode. Red. Wave length is 645 nm approximately. |
| Memory | Last value, Max. value, Min. value. |

2-3 General function

| | |
|-----------------------|---|
| Display | 45 mm x 48 mm LCD size. |
| Circuit | Exclusive microcomputer circuit. |
| Data output | RS 232 serial output. |
| Operating temperature | 0 to 50 °C (32 to 122 °F). |
| Operating humidity | Less than 80% RH. |
| Power supply | 1.5 V battery x 4 PCs UM-3, AA, R6 Alkaline or heavy duty type, |

| | | |
|----------------------|---|-----------------|
| Power consumption | Vibration | Approx. 10.5 mA |
| | Tachometer | Approx. 21 mA |
| Weight | Meter | 397 g/0.87 LB |
| | Probe with magnetic base | 110 g/0.24 LB |
| Dimension | Meter : 46.8 x 75.5 x 188 mm (1.8 x 3.0 x 7.4 inch). | |
| | Vibration sensor probe: Round 18 mm Dia. x 40 mm. | |
| Accessories included | Instruction manual..... 1 PC. Vibration sensor (VB-82)..... 1 PC. Magnetic base..... 1 PC. Reflecting tape marks (600 mm)..... 1 PC. RPM cone rubber..... 1 PC. RPM funnel rubber..... 1 PC. Carrying Case..... 1 PC. | |
| Optional accessories | * Data Acquisition software, SW-U801-WIN * Data Logger software, SW-DL2005 * RS232 cable..... UPCB-02 * USB cable..... USB-01 * IR Temp. probe..... IR-962 | |

3. FRONT PANEL DESCRIPTION

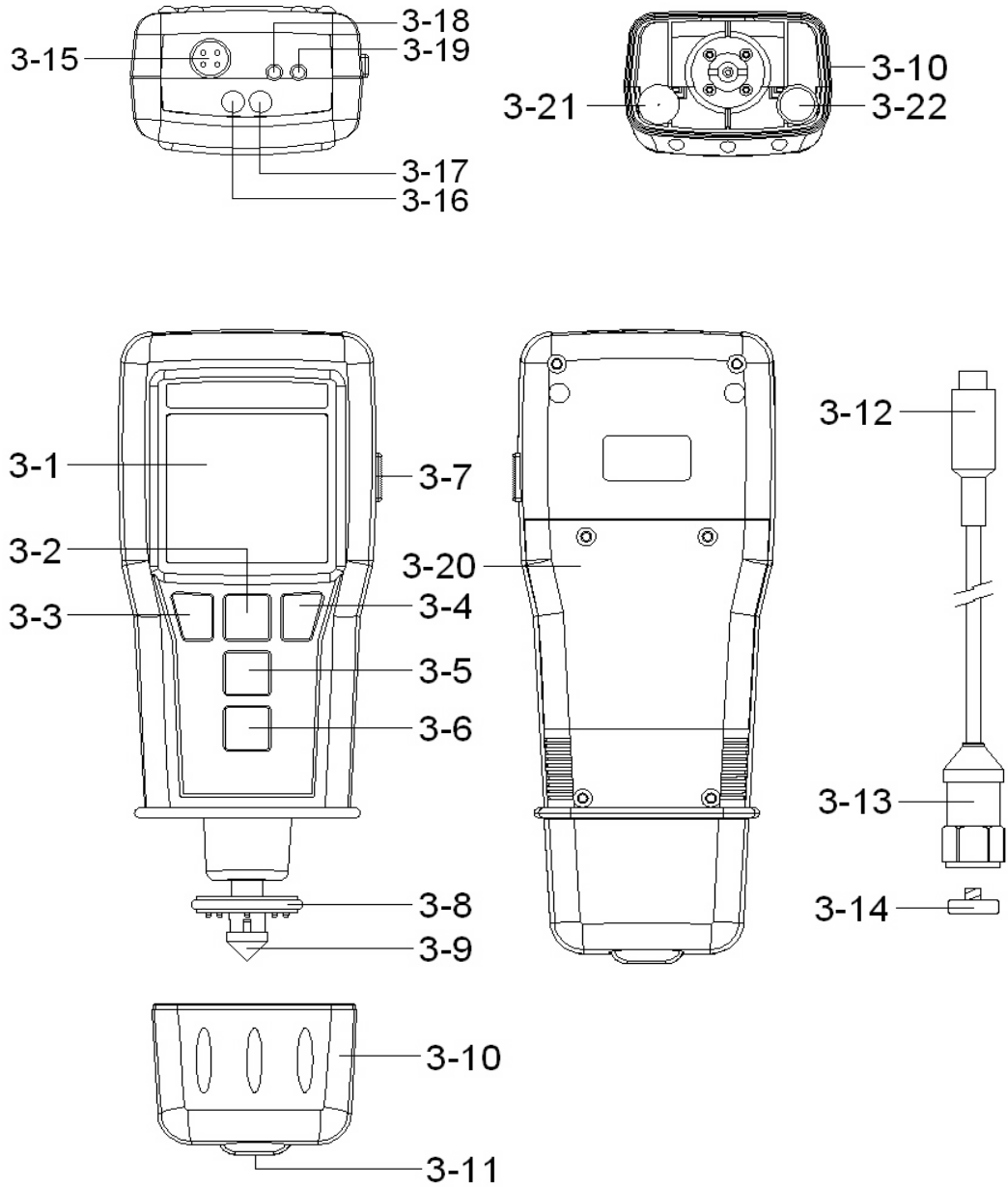

- 3-1 Display
- 3-2 Power button (vibration)
- 3-3 Hold/ESC/Zero button
- 3-4 Eenter/REC button
- 3-5 Function/Send button
- 3-6 Unit/Logger button
- 3-7 Operation button (tachometer)
- 3-8 Surface speed wheel (contact tach.)
- 3-9 RPM adapter (contact tach.)
- 3-10 Protection cover (contact tach.)
- 3-11 Screw for protection cover
- 3-12 Cable plug (vibration sensor)
- 3-13 Vibration sensor
- 3-14 Magnetic base
- 3-15 Input socket (vibration sensor)
- 3-16 Laser light beam (photo tach.)
- 3-17 Photo tach. detecting sensor
- 3-18 IR probe input socket
- 3-19 RS-232 output terminal
- 3-20 Battery cover/battery compartment
- 3-21 Cone rubber (RPM adapter)
- 3-22 Funnel rubber (RPM adapter)

4. VIBRATION MEASURING PROCEDURE

4-1 Basic operation procedures

- 1) Plug in the " Cable plug " (3-12, Fig. 1) to the " Input socket of meter " (3-15, Fig. 1).
- 2) Power on the meter by pressing the " Power button " (3-2, Fig. 1).
- 3)
 - a. For the Acceleration measurement, press the " Unit button " (3-6, Fig. 1) once until the display show the " ACC ", " m/s^2 ", " RMS " symbol or the " ACC ", " g ", " RMS " symbol.
 - b. For the Velocity measurement, press the " Unit button " (3-6, Fig. 1) once until the display show the " VEL ", " mm/s " and " RMS " symbol or the " VEL ", " cm/s " and " RMS " symbol.
 - c. For the Displacement measurement, press the " Unit button " (3-6, Fig. 1) once until the display show the " DISP(P-P) ", " mm " symbol.
- 4) If the surface material of measuring article is not the ferrous material, hold the vibration sensor by hand & touch the sensor to the surface of the measuring article, refer the Fig. 2.

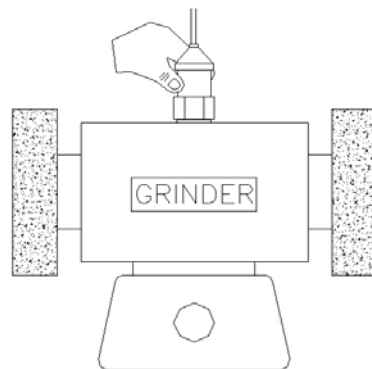

Fig. 2

5) If the surface material of measuring article is the ferrous material, connect " Vibration sensor " (3-13, Fig. 1) with the " Magnetic base " (3-14), refer Fig. 3. Put the whole unit (Vibration sensor & Magnetic base) to the surface of measuring article, refer Fig. 4.

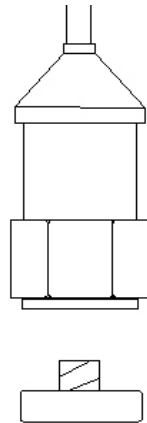

Fig. 3

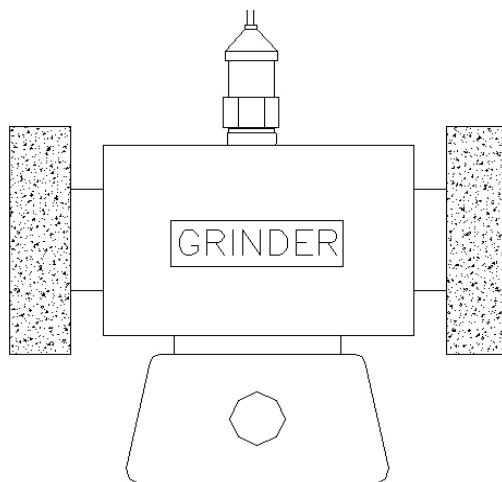

Fig. 4

4-2 Unit selection (Imperial/Metric)

During the measurement, press the " Unit button " (3-6, Fig. 1) at least 2 second continuously, the display unit can be changed from the Imperial unit to Metric unit or be changed from Metric unit to Imperial unit.

The Metric unit are :

Acceleration measurement is m/s^2 or g.

Velocity measurement is mm/s or cm/s.

Displacement (p-p) measurement is mm.

The Imperial unit are :

Acceleration measurement is ft/s^2 .

Velocity measurement is inch/s.

Displacement (p-p) measurement is inch.

4-3 Function selection (RMS/PEAK/MAX HOLD)

During the Acceleration, Velocity, Displacement measurement if press " Function/Send button " (3-5, Fig. 1) once can select the following function :

| | Function 1 | Function 2 | Function 3 |
|--------------------------------|--------------------|---------------------|------------------------------|
| Acceleration (LCD symbol) | ACC RMS | ACC PEAK | ACC PEAK MAX HOLD |
| Velocity (LCD symbol) | VEL RMS | VEL PEAK | VEL PEAK MAX HOLD |
| Displacement (LCD symbol) | DISP(p-p) | ----- | MAX HOLD |

1)Function 1 (RMS for ACC, VEL., p-p for DISP.) :

Function 1 is the basic operation function, for general operation select the function 1 typically.

- * If Acceleration function measure the " RMS " value, the display show " ACC " and " RMS " symbol.
- * If Velocity function measure the " RMS " value. the display show " VEL " and " RMS " symbol.
- * If Displacement function measure the " p-p " (peak to peak) value, the display show " DISP (p-p) " symbol.
The definition of " peak to peak ", please refer Fig. 6

2)Function 2 (Peak , for ACC. and VEL, only) :

- * If Acceleration function measure the " Peak " value, the display show " ACC " and " PEAK " symbol.
- * If Velocity function measure the " Peak " value. the display show " VEL " and " PEAK " symbol.
The definition of " Peak ", refer Fig. 5.

3)Function 3 (Max. hold, for ACC., VEL and DISP.) :

- * If Acceleration function measure the " Max. peak " value with hold. the display show " ACC " and " PEAK MAX HOLD " symbol.
The definition of " Max. peak hold " value, refer Fig. 5.
- * If the Velocity function measure the " Max. peak " value with hold the display show " VEL " and " PEAK MAX HOLD " symbol.
The definition of " Max. peak hold " value, refer Fig. 5.

* The Displacement function measure the max. " p-p " (peak to peak) value with hold, the display show " DISP (p-p) " and " MAX HOLD " symbol.

The definition of " peak to peak ", please refer Fig. 6

* **Max. hold reset :**

If intend reset the " MAX HOLD " value, just press the " Zero button " (3-3, Fig. 1) > 2 sec continuously, the display will return to zero and make the new max. hold value measurement again.

Fig. 5

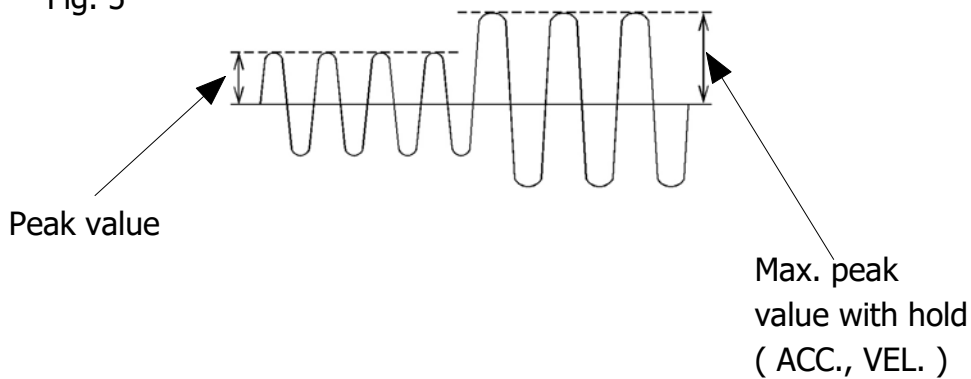
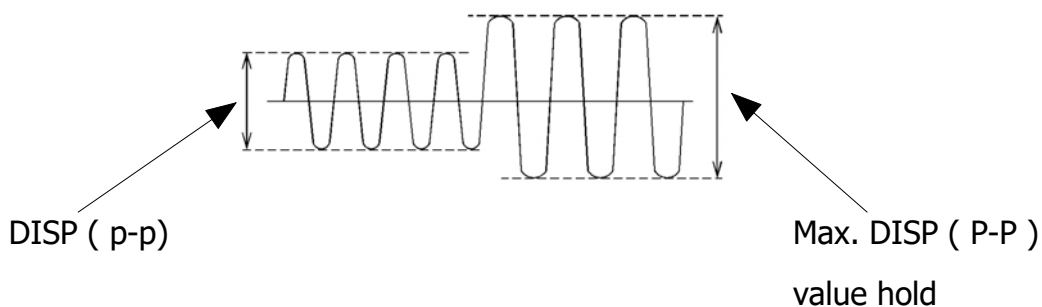

Fig. 6



4-4 Data hold

During the measurement, push the " Hold button " (3-3, Fig. 1) will hold the measured value & the LCD will show " HOLD " symbol.

Push the " Hold button " again to release the data hold function.

4-5 Data Record (Max., Min. reading)

The DATA RECORD function displays the maximum, minimum readings for the measurement of

Acceleration (RMS)

Velocity (RMS)

Displacement (p-p)

- 1) Press the " REC button " (3-4, Fig. 1) once to start the Data Record function. " REC " will be displayed.
- 2) With the " REC " symbol on the display :
 - a) Press the " REC button " (3-4, Fig. 1) once, the " REC MAX. " symbol along with the maximum value will appear on the display.
To delete the maximum value, just press the " Hold button " (3-3, Fig. 1) once. The display will show " REC " and execute the memory function continuously.
 - b) Press the " REC button " (3-4, Fig. 1) again, the " REC MIN. " symbol along with the minimum value will appear on the display. To delete the minimum value, just press the " Hold button " (3-3, Fig. 1) once, then the display will show the " REC " symbol only and execute the memory function continuously.

c) To exit the memory record function, just press the " REC button " for at least 2 seconds. The display will revert to the current reading.

4-6 Zero adjustment procedure

Due to drift of environment temperature value, battery power change or, meter used for a long time or other reasons. The display value may exist not zero value (few digits) in case of no signal into the " Vibration Sensor ". General speaking those not zero value will not effect the measurement typically. However if intend to make the precision measurement, the following zero adjustment procedures should be executed as :

- 1) Press the " Function button " (3-5, Fig. 1) to the " Acceleration " position.
- 2) No signal into the vibration sensor.
- 3) Press the " Zero button " (3-3, Fig. 1) continuously at least 2 second, the display will return to zero value with default.

4-7 Data Logger

The data logger function can save 1000-point data for the vibration function.

The data logger procedures are as following :

- a) Press the " REC Button " (3-4, Fig. 1) once to start the Data Record function and there will be a " REC. " symbol on the display.

b) Auto Data Logger (Sampling time can select to 1, 2, 10, 30, 60, 600, 1800, 3600 seconds)

Press the " Logger Button " (3-6, Fig. 1) once to start the Data Logger function. The " (•) " symbol is flashed per the sampling time and the data will be saved into the memory circuit.

Now the Date Logger function is executed.

Manual Data Logger (Sampling time set to 0 second)

Press the " Logger Button " (3-6, Fig. 1) once will save the data one time into the memory circuit.

At the same time the " (•) " symbol will be flashed.

Memory full

During execute the data logger function, if the display show " FULL ",

it indicate the memory data already over 1000 no. and the memory is full.

c) During the Data Logger function is executed, press the " Logger button " (3-6, Fig. 1) once will stop to execute the data logger function, the symbol " (•) " will be disappeared. If press the " Logger Button " (3-6, Fig. 1) once again will continuous the Data Logger function.

Remark :

- 1) If intend to change the data logger sampling time, please refer section 4-10/point 4, page 19.*
- 2) If intend to know the space of balance data numbers into the memory IC, please refer section 4-10/point 5, page 19.*
- 3) If intend to clear the saving data from the memory please refer section 4-10/point 6, page 20.*

4-8 How to send the data out from the meter

- 1) Before sending data out from the meter, exit the " Hold function " and the " Record " function.
- 2) Press the " Send Button " (3-5, Fig. 1) at least 2 seconds until display show " r-232 ", then release the button.
- 3) Push the " Send Button " (3-5, Fig. 1) once, display will count down, at the same the storage data logger data will send out the meter from the " RS-232 Output Terminal " (3-19, Fig. 1).
- 4) If intend load the data to the computer, it should connect the RS232 cable (optional, model : UPCB-02) or USB cable (optional, model : USB-01) and apply the Data Logger software (optional, Model : SW-DL2005).

4-9 Auto power off

The meter is default to auto power off.

If the user intend to disable the " Auto Power off " function, refer the section 4-10/point 3, page 18.

Note :

During execute the record function, the auto power function will disable too.

4-10 Advanced setting procedure

1) Power off the meter, first use the finger to press the the " Hold button " (3-3, Fig. 1) continuously, then press the " Power button " (3-2, Fig. 1) once. Release the finger from " Hold button ".

2) One by one to press the " Hold button " (3-3, Fig. 1) once a while to select the five four function and display will show flashing text with as :

OFF.....Auto power On/Off management

SEC..... Change the data logger sampling time

Cnt..... To show the balance data numbers in the memory

CLr.....Clear the existing saving data from the memory

ESC.....Escape the advanced setting function

3) **Auto power On/Off**

a. Use the " Hold button " to select the main function to " OFF ".

- b. Press the " Function button " (3-5, Fig. 1) or " Unit button " (3-6, Fig. 1) to select " 1 " or " 0 ".
- * *If the display value show " 0 ", it will disable the Auto Power Off function.*
 - * *If the display value show " 1 ", it will execute the Auto PowerOff function.*
- c. After select the desiring value (1 or 0), press the " Enter button " (3-4, Fig. 1) to save the data with default.

4) *Change the data logger sampling time*

- a. Use the " Hold Button " to select the main function to " SEC ".
- b. Press the " Function button " (3-5, Fig. 1) or " Unit button " (3-6, Fig. 1) to select the data logger sampling time to 0, 1, 2, 10, 30, 60, 600, 1800, 3600 seconds.
- c. After the sampling time value is determined, press the " Enter button " (3-4, Fig. 1) to save the sampling time with default.

5) *To show the balance data numbers in the memory*

Use the " Hold button " to select the main function to " Cnt ".

In the same time display will show the balance data point that exist into the memory (allow memorize data no.).

6) *Clear the existing saving data from the memory*

- a. Use the " Hold button " to select the main function to " CLr ".
- b. Press the " Function button " (3-5, Fig. 1) or " Unit button " (3-6, Fig. 1) to select " 1 " or " 0 ".
 - * *If the display value show " 0 ", it will be not to clear the memory.*
 - * *If the display value show " 1 " will execute the memory clear function..*
- c. After select the desiring value (1 or 0), press the " Enter button " (3-4, Fig. 1) to save the data with default.

7) *ESC*

- a. Use the " Hold button " to select the main function to " ESC ".
- b. Press the " ESC button " (3-3, Fig. 1) will escape the above advanced setting function.

5. TACHOMETER MEASURING PROCEDURE

5-1 Change the function

- 1) Press the " Operation Button " (3-7, Fig. 1) continuously an not release the finger from the button.
- 2) Press " Function Button " (3-5, Fig. 1) momentarily in sequence, the function will change to

- a. Contact RPM measurement, display shows " RPM " symbol.
- b. Surface speed (m/min.) measurement, display shows " m/min " symbol.
- c. Surface speed (ft/min.) measurement, display shows " ft/min " symbol.
- d. Photo RPM measurement, display shows " RPM " symbol, at the same the " Laser Light Beam " (3-16) will be generated.

Note :

- * **After the function be selected, release the buttons, the function will saved into the meter even turn off the meter.**
- * **Turn on the meter again, the existing select function will present .**

5-2 Photo RPM measurement

- 1) Select (default) the function to " Photo RPM ", refer chapter 5-1, page 20, 21.
- 2) Apply a " Reflecting Mark " to the object being measured. Press the " Operation button " (3-7, Fig. 1) continuously and align the " Laser Light Beam " (3-16, Fig. 1) with the applied target. Verify that the LCD " Monitor Indicator " ((•)) lights when the target pass through the light beam.

Measuring consideration :

If the measured RPM values is very low (for example less than 50 RPM), recommend to attach more " Reflecting Marks " average to the object. It will get the real RPM with high resolution, precisely & fast sampling time when divided the reading values by the no. of the " Marks ".

5-3 Contact RPM measurement

- 1) Select (default) the function to " Contact RPM ", refer chapter 5-1, page 20, 21.
- 2) Press the " Operation Button " (3-7, Fig. 1) & lightly pressing the " RPM Adapter " (3-9, Fig. 1) against the center hole on the hole of the measured rotating axis. Release the " Measuring Button " when the reading stabilizes (approx. 2 sec.).

5-4 Surface Speed Measurement

- 1) Select (default) the function to surface speed " m/min " or " ft/min ", refer chapter 5-1, page 5.
- 2) Press the " Operation button " (3-7, Fig. 1) and simply attaching the " Surface Speed Wheel " (3-8, Fig. 1) to the detector. Release the " Power Button " when the reading stabilizes (approx. 2 sec.).

5-5 Memory recall

- 1) The readout of " last value ", " max. value " & " min. value " can be obtained immediately & memorized into the circuit automatically after turning off the " Operation Button " (3-7, Fig. 1)

2) When finish the measuring procedures (after release the operation button), the memorized values can be displayed on the LCD display whenever :

- a. First push the " REC button " (3-4, Fig. 1) -
To display the last value (" LA " and " the last value " will be displayed alternately).
- b. Second, push the " REC button " again -
To display the maximum value (" UP " and " the max. value " will be displayed alternately).
- c. Third, push the " REC button " again -
To display the minimum value (" dn " and " the min. value " will be displayed alternately).

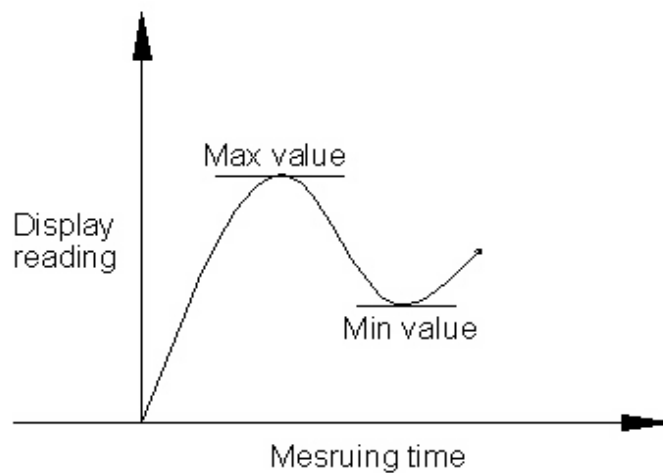

6. IR (Infrared) TEMPERATURE MEASURING PROCEDURE

- 1) Power off the meter.
- 2) Prepare the IR Temp. probe (optional, IR-962), connect the cable plug of IR Temp. probe into the " IR probe input socket " (3-18, Fig. 1).
- 3) Power on the meter.
- 4) Power on the IR Temp. probe.

7. RS232 PC SERIAL INTERFACE

The instrument has RS232 PC serial interface via a 3.5 mm terminal (3-19, Fig. 1).

The data output is a 16 digit stream which can be utilized for user's specific application.

A RS232 lead with the following connection will be required to link the instrument with the PC serial port.

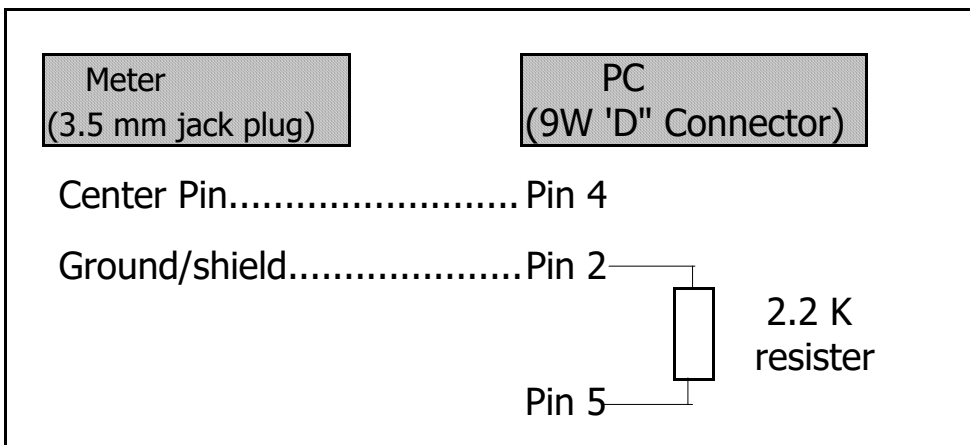

The 16 digits data stream will be displayed in the following format :

D15 D14 D13 D12 D11 D10 D9 D8 D7 D6 D5 D4 D3 D2 D1 D0

Each digit indicates the following status :

| | | | |
|---|---|------------------------|--------------|
| D15 | Start Word = 02 | | |
| D14 | 4 | | |
| D13 | 1 | | |
| D12, D11 | Annunciator for Display | | |
| <i>For example mm/s=93 D12=9, D11=3</i> | mm/s = 93 | ft/s ² = 97 | ft/min. = 11 |
| | cm/s = 95 | mm = 94 | °C = 01 |
| | in/s = 98 | inch = 96 | °F = 02 |
| | m/s ² = 92 | RPM = 27 | |
| | g = 57 | m/min. = 60 | |
| D10 | Polarity 0 = Positive 1 = Negative | | |
| D9 | Decimal Point(DP), position from right to the left 0 = No DP, 1= 1 DP, 2 = 2 DP, 3 = 3 DP | | |
| D8 to D1 | Display reading, D8 = MSD, D1 = LSD For example : If the display reading is 1234, then D8 to D1 is : 00001234 | | |
| D0 | End Word = 0D | | |

RS232 setting

| | |
|--------------|-------------|
| Baud rate | 9600 |
| Parity | No parity |
| Data bit no. | 8 Data bits |
| Stop bit | 1 Stop bit |

8. BATTERY REPLACEMENT

- 1) When the left corner of LCD display show "  ", it is necessary to replace the battery. However, in-spec measurement may still be made for several hours after low battery indicator appears before the instrument become inaccurate.
- 2) Open the " Battery Cover " (3-20, Fig. 1) away from the instrument and remove the battery.
- 3) Install 1.5 V battery x 4 PCs (UN-3, AA, Alkaline or heavy duty) and replace the cover.

9. OPERATIONAL ACCESSORIES

| | |
|---|--|
| RS232 cable UPCB-02 | * COM port Computer interface cable. * Isolated RS232 cable. |
| USB cable USB-01 | * USB Computer interface cable. * Isolated RS232 cable. |
| Data Logger software SW-DL2005 | * Software the used to download the data logger (data recorder) from the meter to computer. |
| Data Acquisition software SW-U801-WIN | * The SW-U801-WIN is a multi displays (1/2/4/6/8 displays) powerful application software, provides the functions of data logging system, text display, angular display, chart display, data recorder high/low limit, data query, text report, chart report.. .xxx.mdb data file can be retrieved for EXCEL, ACCESS., wide intelligent applications. |

| | |
|--------------------------|------------------------------|
| IR Temp. probe IR-962 | * Infrared temperature probe |
|--------------------------|------------------------------|

10. CLASSIFICATION RANGES

For the valuation of machines and equipment in the ISO 2372 and VDI 2056, four different kinds of machine groups with four classification ranges and their limits for vibration severity (mm/s) are determined.

The classifications for each machine group are specified as follows :

Small machines, especially production electrical motors of up to 15 KW (Group K)

| | |
|-------------------|-------------------|
| Good | 0 to 0.71 mm/s |
| Acceptable | 0.72 to 1.80 mm/s |
| Still permissible | 1.81 to 4.5 mm/s |
| Dangerous | > 4.5 mm/s |

Medium sized machines, especially electrical motors with 15 up to 75 KW output, without special foundations (Group M)

| | |
|-------------------|-------------------|
| Good | 0 to 1.12 mm/s |
| Acceptable | 1.13 to 2.80 mm/s |
| Still permissible | 2.81 to 7.1 mm/s |
| Dangerous | > 7.1 mm/s |

Large machines on heavy foundations (Group G)

| | |
|-------------------|-------------------|
| Good | 0 to 1.80 mm/s |
| Acceptable | 1.81 to 4.50 mm/s |
| Still permissible | 4.51 to 11.2 mm/s |
| Dangerous | > 11.2 mm/s |

Largest machines and turbo machines with a special foundations (Group T).

| | |
|-------------------|-------------------|
| Good | 0 to 2.80 mm/s |
| Acceptable | 2.81 to 7.10 mm/s |
| Still permissible | 7.11 to 18.0 mm/s |
| Dangerous | > 18 mm/s |

11 SENSITIVITY RELATIVE TABLE ACCORDING ISO 2954

| Frequency | | Relative sensitivity | | |
|-----------|----|----------------------|---------------|---------------|
| | | Normal value | Minimum value | Maximum value |
| 10 | Hz | 1.0 | 0.8 | 1.1 |
| 20 | Hz | 1.0 | 0.9 | 1.1 |
| 40 | Hz | 1.0 | 0.9 | 1.1 |
| 80 | Hz | 1.0 | 1.0 | 1.0 |
| 160 | Hz | 1.0 | 0.9 | 1.1 |
| 500 | Hz | 1.0 | 0.9 | 1.1 |
| 1000 | Hz | 1.0 | 0.8 | 1.1 |

Table 1