

Apr.1.2023 Copyright 2023 HIROSE ELECTRIC CO., LTD. All Rights Reserved.
In case of consideration for using Automotive equipment / device which demand high reliability, kindly contact our sales window correspondents.

5					6					7					8				
COUNT	DESCRIPTION OF REVISIONS				B	Y	CHKD	DATE	COUNT	DESCRIPTION OF REVISIONS				B	Y	CHKD	DATE		
△									△										
△									△										
△									△										

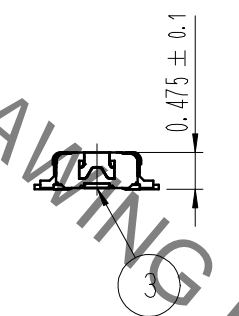

ENGAGEMENT FIGURE (50:1)

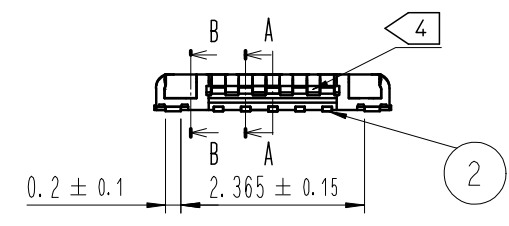
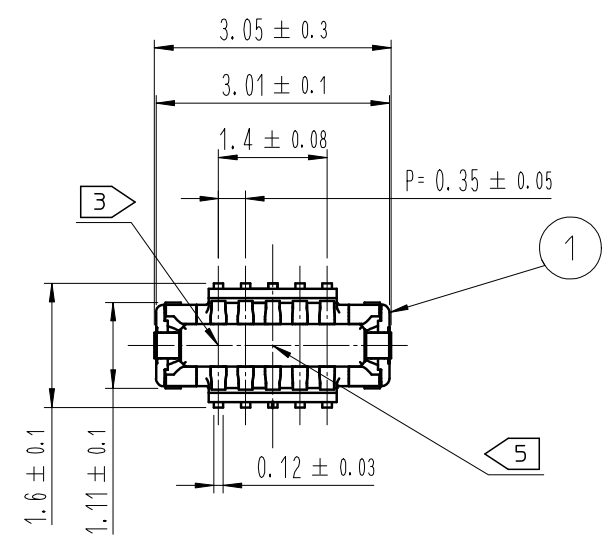
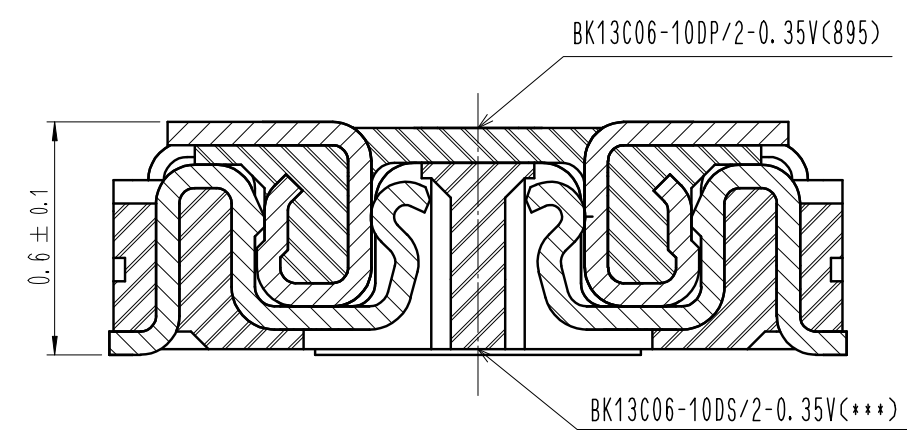

SIGNAL CONTACT

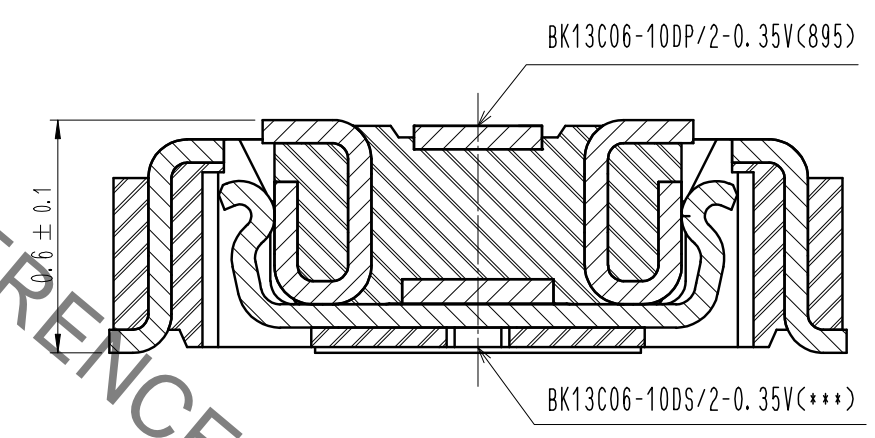

POWER CONTACT

A-A (30:1)

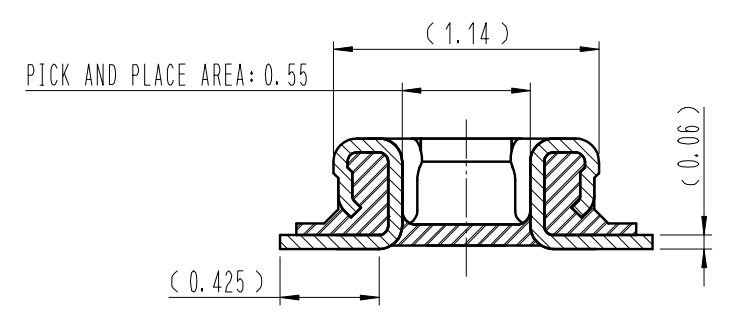

B-B (30:1)

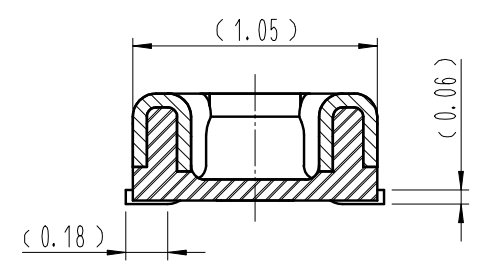

- NOTE
- 1. ALL LEAD CO-PLANARITY SHALL BE 0.08mm MAX.
 - 2. CONTACT PLATING SPECIFICATIONS
CONTACT AREA : GOLD 0.05 μm MIN
SMT LEAD : GOLD 0.05 μm MIN
UNDERPLATING : NICKEL 1 μm MIN
(SURFACE : SEALING)
 - 3. CAV NO. ARE INDICATED IN APPROX POSITION SHOWN.
 - 4. A PART OF THE WALL COULD BE NOTCHED
 - 5. DENT EXISTS IN THE INDICATED AREA FOR MANUFACTURING CONVENIENCE.

4	PS	CLEAR (EMBOSSD CARRIER TAPE)					
3	COPPER ALLOY	2					
2	COPPER ALLOY	2					
1	LCP	UL94 V-0, BLACK	6	PS	BLACK (PLASTIC REEL)		
			5	POLYESTER	CLEAR (COVER TAPE)		
NO.	MATERIAL	FINISH, REMARKS	NO.	MATERIAL	FINISH, REMARKS		
REMARKS				DRAWN	DESIGNED	CHECKED	APPROVED
				S. H. PARK	S. H. PARK	H. W. JO	H. W. JO
				20.10.05	20.10.05	20.10.05	20.10.05
CODE NO. (OLD)				DRAWING NO.		PART NO.	
				EDC3-633003-95		BK13C06-10DP/2-0.35V(895)	
SCALE				UNITS		CODE NO.	
10:1				mm		CL 6665-0034-7-895	
HRS HIROSE KOREA CO., LTD.						1/3	

Apr.1.2023 Copyright 2023 HIROSE ELECTRIC CO., LTD. All Rights Reserved.
In case of consideration for using Automotive equipment / device which demand high reliability, kindly contact our sales window correspondents.

7 **RECOMMENDED PCB LAYOUT**

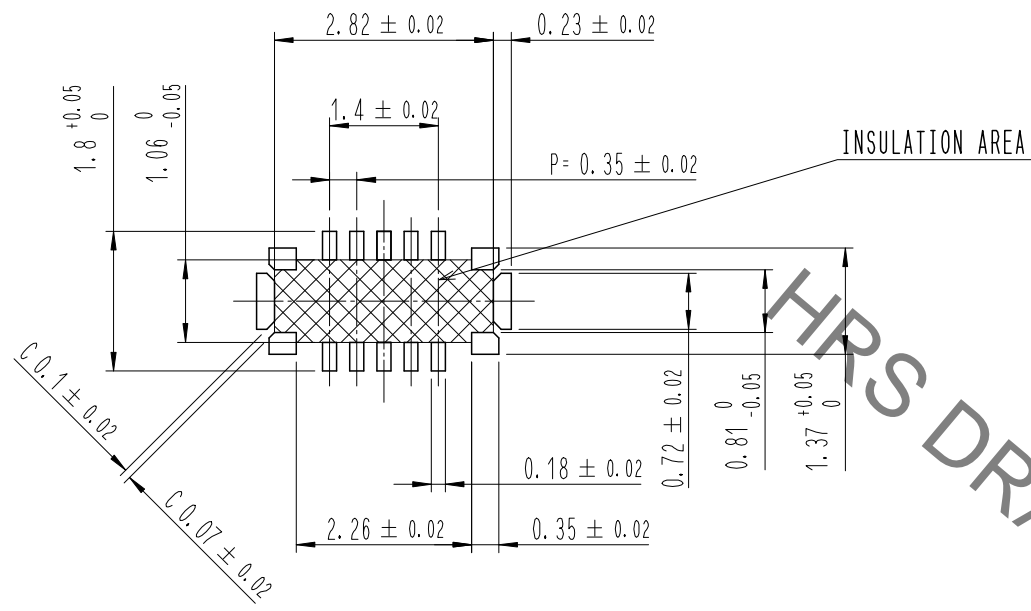

8 **RECOMMENDED METAL MASK DIMENSIONS**
METAL MASK THICKNESS : 80 μm

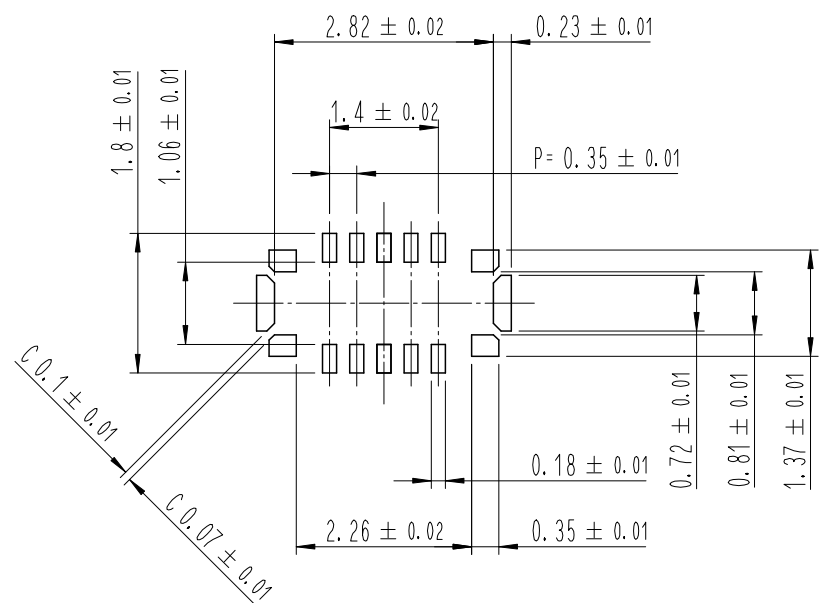

6 **RECOMMENDED REFLOW TEMPERATURE PROFILE USING LEAD-FREE SOLDER PASTE.**

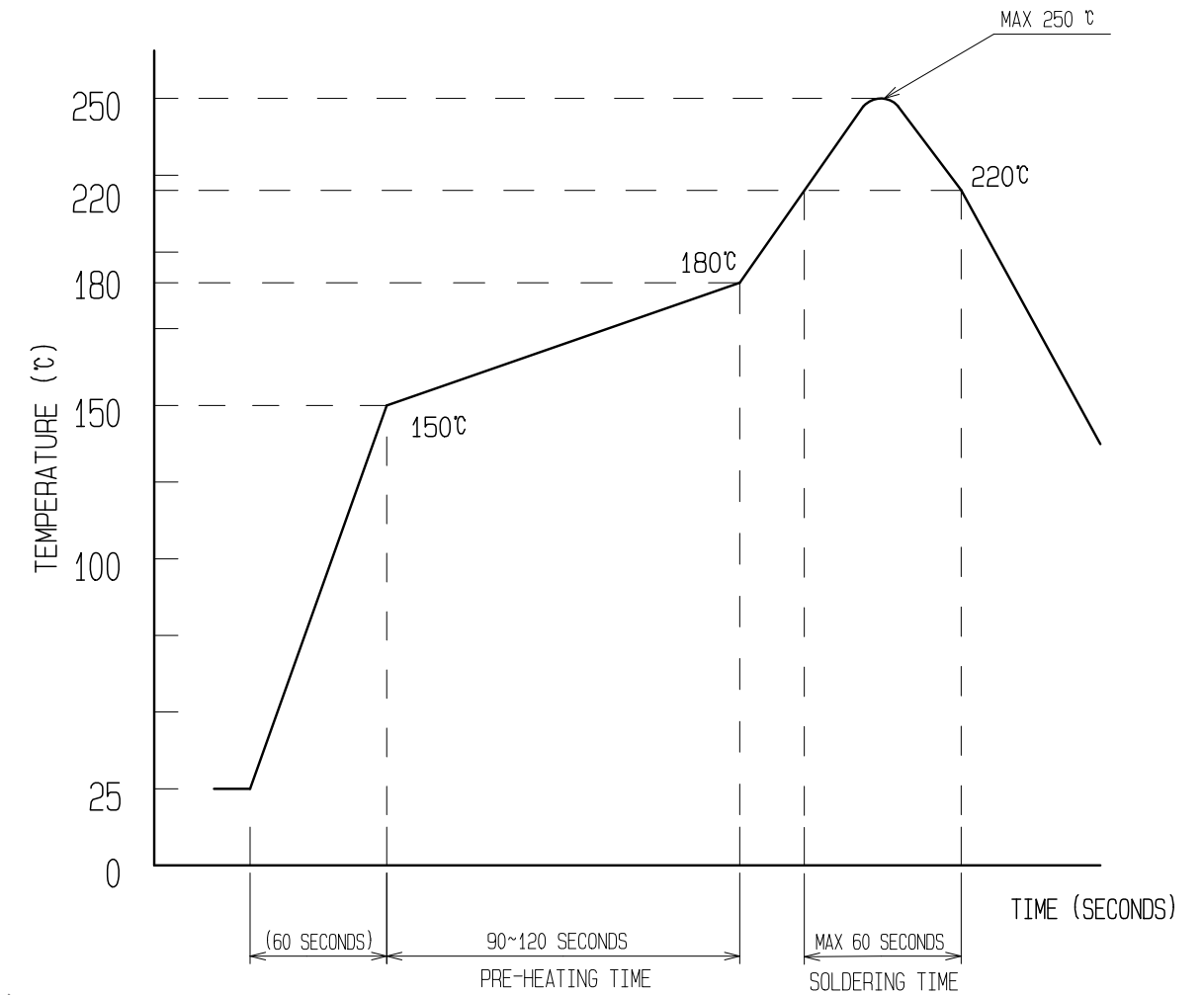

REFLOW METHOD : N₂ REFLOW
 NUMBER OF REFLOW CYCLES : 2 CYCLES MAX.
 1) REFLOW TIME
 DURATION ABOVE 220°C, 60 SEC MAX.
 (PEAK TEMPERATURE : 250°C MAX)
 2) PRE-HEAT TIME
 PRE-HEAT TEMPERATURE(MIN): 150°C
 PRE-HEAT TEMPERATURE(MAX): 180°C
 PRE-HEAT TIME: 90-120 SEC.

6 THIS TEMPERATURE PROFILE IS PER THE CONDITIONS SHOWN ABOVE. ADDITIONAL FACTORS SUCH AS SOLDER PASTE TYPE, PCB SIZE AND OTHER MOUNTED COMPONENTS COULD AFFECT THE PROFILE. THEREFORE, A THOROUGH EVALUATION OF MOUNTING CONDITION IS REQUIRED PRIOR TO PRODUCTION. TEMPERATURE IS MEASURED AT CONTACT LEAD.

7 PLEASE CONTACT US IN CASE YOU WILL MAKE DIFFERENT SETTINGS FROM OUR RECOMMENDATION.
 8 . THIS PRODUCT SATISFIES HALOGEN FREE REQUIREMENTS DEFINED AS 900ppm MAXIMUM CHLORINE, 900ppm MAXIMUM BROMINE, AND 1500ppm MAXIMUM TOTAL OF CHLORINE AND BROMINE.
 9 . THIS PRODUCT COMPLY WITH RoHS.

HRS DRAWING FOR REFERENCE

	DRAWING NO.	EDC3-633003-95	PART NO.	BK13C06-10DP/2-0.35V(895)	
	SCALE	10:1	CODE NO	CL 6665-0034-7-895	2/3
UNITS	mm		HRS HIROSE KOREA CO., LTD.		

Apr.1.2023 Copyright 2023 HIROSE ELECTRIC CO., LTD. All Rights Reserved.
 In case of consideration for using Automotive equipment / device which demand high reliability, kindly contact our sales window correspondents.

EMBOSED CARRIER TAPE PACKAGING (5:1)

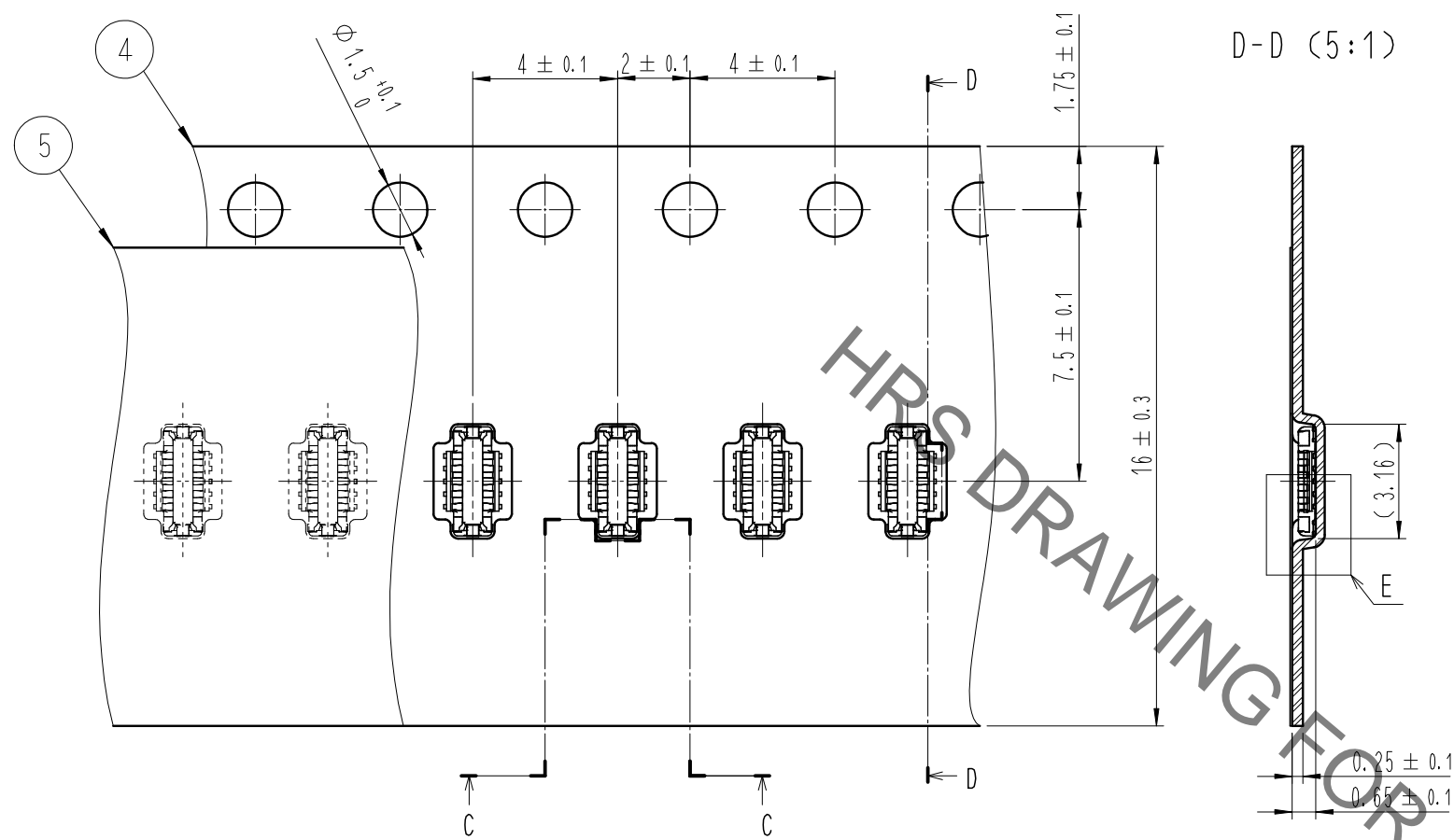

D-D (5:1)

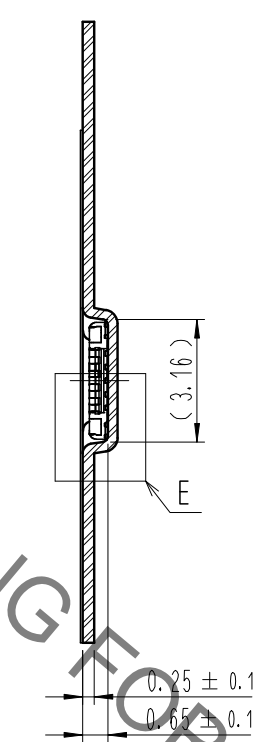

C-C (5:1)

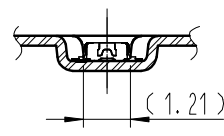

DIRECTION OF UNREELING

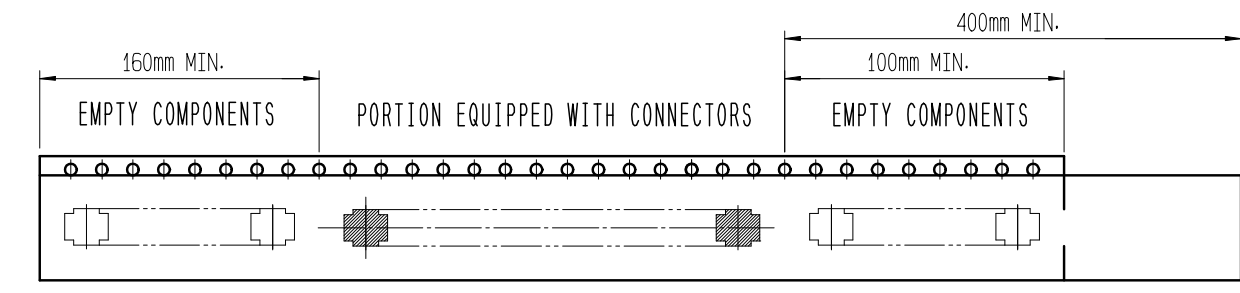
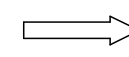

TRAILER

LEADER

TAPING (FREE)

STYLE AND DIMENSION OF REEL (FREE)

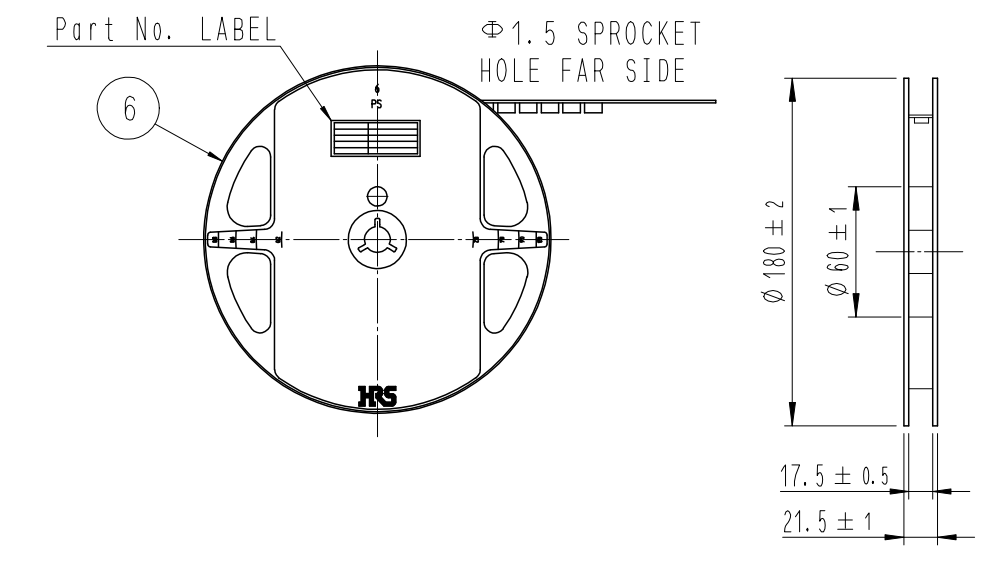

DETAIL OF PART No. LABEL

SUPPLIER	
QUANTITY	
PART NO.	
CODE NO.	
DATE OF MANUFACTURED	
生産月日	年 月 日
図番	** ** *
品名	BK13C06-10DP/2-0.35V(895)
納入数量	1,000個
納入者	HIROSE KOREA

- 10 . PER REEL 1,000 CONNECTORS.
- 11 . THE DIMENSIONS IN PARENTHESES ARE FOR REFERENCE.
- 12 > REFER TO JIS C 0806, IEC-60286-3 (PACKAGING OF COMPONENTS FOR AUTOMATIC HANDLING)

	DRAWING NO.	EDC3-633003-95	PART NO.	BK13C06-10DP/2-0.35V(895)	
	SCALE	10:1	CODE NO.	CL 6665-0034-7-895	3/3
UNITS	HIROSE KOREA CO., LTD.				