

# AEV150 Series DC Contactor Specification



## Application

AEV150 series DC contactors are used for battery power supply, DC power control, circuit protection and other electric vehicle power switch controls. Can also be used in uninterruptible power supply and other electronic control systems.

## Features

### HIGH CURRENT AND HIGH VOLTAGE

Nitrogen sealed contacts to minimize arcing.

### COMPACT STRUCTURE, LOW NOISE

Contact design yields reduced unit size, low noise while carrying or switching currents.

### COIL ECONOMIZER

Built-in coil economizer – only 1.7W holding power @12VDC, limits back EMF to 0V.

### HIGH SAFETY

There is no arc leakage due to tight sealing.

### HIGH CONTACT RELIABILITY

Stable contact resistance no matter how harsh the environment with sealed contacts.

### NO SPECIAL MOUNTING REQUIREMENT

Light weight actuator is less impacted by gravity with no special mounting orientation requirements.

### VARIOUS APPLICATIONS

Application includes battery switch and standby equipment, DC power control, circuit protection, etc.

### OPTIONAL AUXILIARY CONTACT

Allows for contact position signal.

### EU ROHS DIRECTIVE (2011/65/EU) COMPLIANT



UL FILE NUMBER: E501749

## Nomenclature

Example

AEV150

–

M

AN

Series code:

“AEV150” = AEV150 Series

Coil Voltage Code:

“M” = 12 - 24 VDC

Options (applied in this order):

Blank = Std. Options (Bottom Mount, Without Aux. Contact & Polarized Load Terminals)

“A” = With Aux. Contact (SPST-NO)

“N” = Non-Polar Load Terminals

# AEV150 Series DC Contactor Specification

## Performance Data

MAIN CONTACT		LIFE	
Contact arrangement	1 Form X (SPST-NO DM)	Resistive load life	See chart below
Rated Operating Voltage	12-900VDC	Mechanical life	200,000 cycles
Continuous (Carry) Current	150A -200A (65 °C)	AUX. CONTACT	
Make/Break current	See chart below	Aux. Contact arrangement	1 Form A
Max short circuit current	2,000A @320VDC, 1 cycle <sup>*1</sup>	Aux. Contact Current Max	2A@30VDC/ 3A@125VAC
Dielectric Withstanding Voltage	Between open contacts: 2,200Vrms, ≤1mA	Aux. Contact Current Min	100mA@8V
	Between contact and coil: 2,200 Vrms, ≤1mA	Max Contact Resistance	0.417ohms@30VDC/ 0.150ohms @125VAC
Insulation Resistance <sup>*2</sup>	Terminal to Terminal/ Terminal to coil		
	New: Min 100 MΩ @500Vdc End of life: Min 50 MΩ @500Vdc		
Voltage Drop (@150A)	≤60mV		
ENVIRONMENTAL DATA		OPERATE / RELEASE TIME	
Shock, 11ms ½ sine, operating	20G Peak	Close (includes bounce)	25ms, Max.
Vibration, Sine, Peak, 20G	80–2,000Hz	Bounce (after close only)	7ms, Max.
Operating Ambient Temperature	-40 to +85 °C	Release (@2000A includes arc)	12ms, Max.
Altitude	<4000m		
Weight	0.95 Lb (0.43 kg)		
COIL DATA			
Coil Voltage	9-36VDC		
Voltage (Max.)	36VDC		
Pickup voltage (Max.)	9VDC		
Hold voltage (Min.)	7.5 VDC		
Dropout voltage (Min.)	6VDC		
Inrush Current (Max.)	3.8A		
Holding Current (Avg.)	0.13A@12VDC / 0.07A@24VDC		

### Note:

\*1: Does not meet dielectric & IR after test.

# AEV150 Series DC Contactor Specification

## Estimated Make & Break Resistive Load Ratings

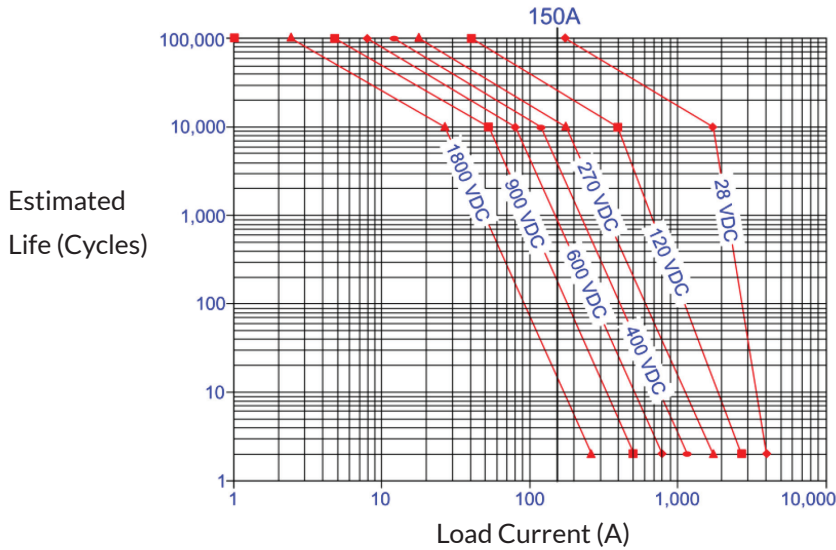

### Note:

1. For resistive loads with 300uH maximum inductance.
2. The maximum make current is 650A to avoid contact welding.
3. Estimates based on extrapolated data. User to confirm performance in application.

## Electrical Load Life Ratings for Typical EV Applications

### MAKE/BREAK LIFE CAPACITIVE & RESISTIVE LOADS AT 320VDC<sup>\*1</sup>

@90% pre-charge (make only), see chart below	50,000 cycles
@Min 80% pre-charge (make only), see chart below	50 cycles

### Note:

\*1: Resistive load includes L=25uH. Load @2500A, test @200uH

## AEV150 Capacitive Make Test Curves for Pre-Charged Motor Controller

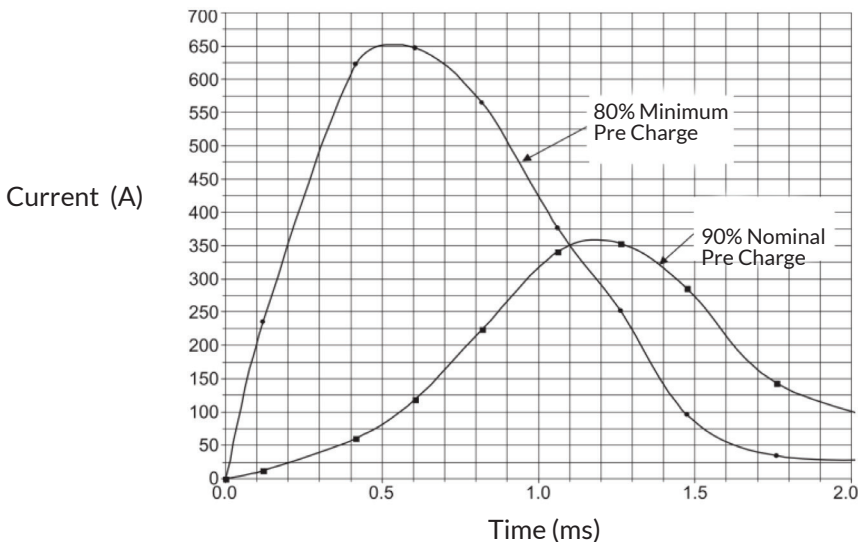

# AEV150 Series DC Contactor Specification

## Outline Dimensions: in. (mm)

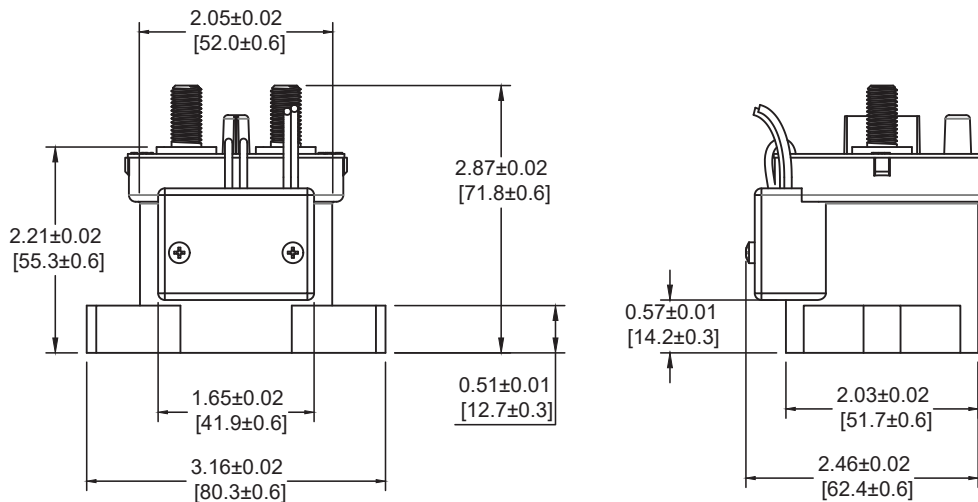
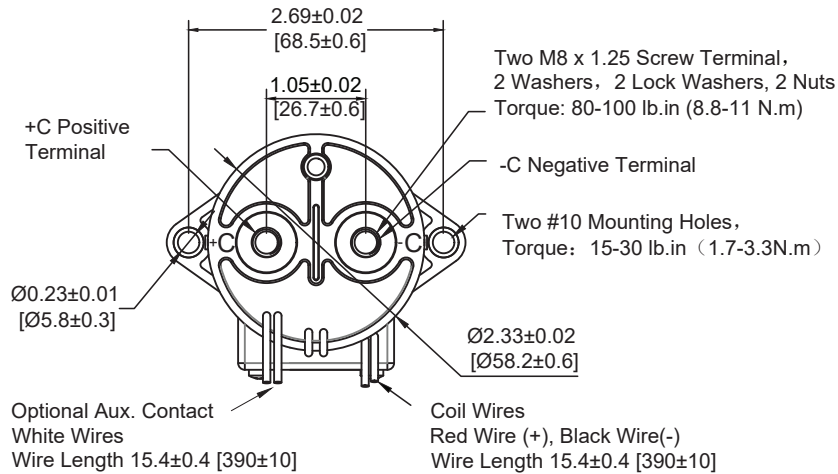

# AEV150 Series DC Contactor Specification

## Application Note:

1. Be sure to use washer to prevent screws from loosening. Screw tightening torque range is specified as below. Exceeding the maximum torque can lead to product failure.
  - Contact torque (M8): 80 - 100 lb.in (8.8 - 11 N.m)
  - Mounting torque: 15 - 30 lb.in (1.7 - 3.3 N.m)
2. Contact Terminals are polarized so refer to drawing during connecting. There is a reverse surge absorption circuit so that it is not necessary to use a surge protective device.
3. Do not use if dropped.
4. Avoid installing in a strong magnetic field (close to a transformer or magnet), or near a heat source.
5. Electrical life  
Use per load capability and life cycle limits so as not to cause a failure. (treat the contactor as a product with specified life and replace it when necessary). It is possible to make parts burn around the contactor once operating failure occurs. It is necessary to take layout considerations into account and to make sure power shall be cut off within 1 second.
6. Lifetime of internal gas diffusion  
The contactor is sealed and filled with gas, lifetime of gas diffusion is determined by temperature in contact chamber (ambient temperature + temperature generated by contact operation). Operate only in an ambient temperature from -40 to +85 °C.
7. If inductive load(L/R>1ms) then a surge current protection device should be connected in parallel to the inductive load.
8. Drive power must be greater than coil power or it will reduce performance capability.
9. Avoid debris or oil contamination of the main terminals to optimize contact and avoid excess heat generation.
10. Unit operates after power applied for 0.1s, do not rapidly switch unit.