

May.1.2023 Copyright 2023 HIROSE ELECTRIC CO., LTD. All Rights Reserved.  
In case of consideration for using Automotive equipment / device which demand high reliability, kindly contact our sales window correspondents.

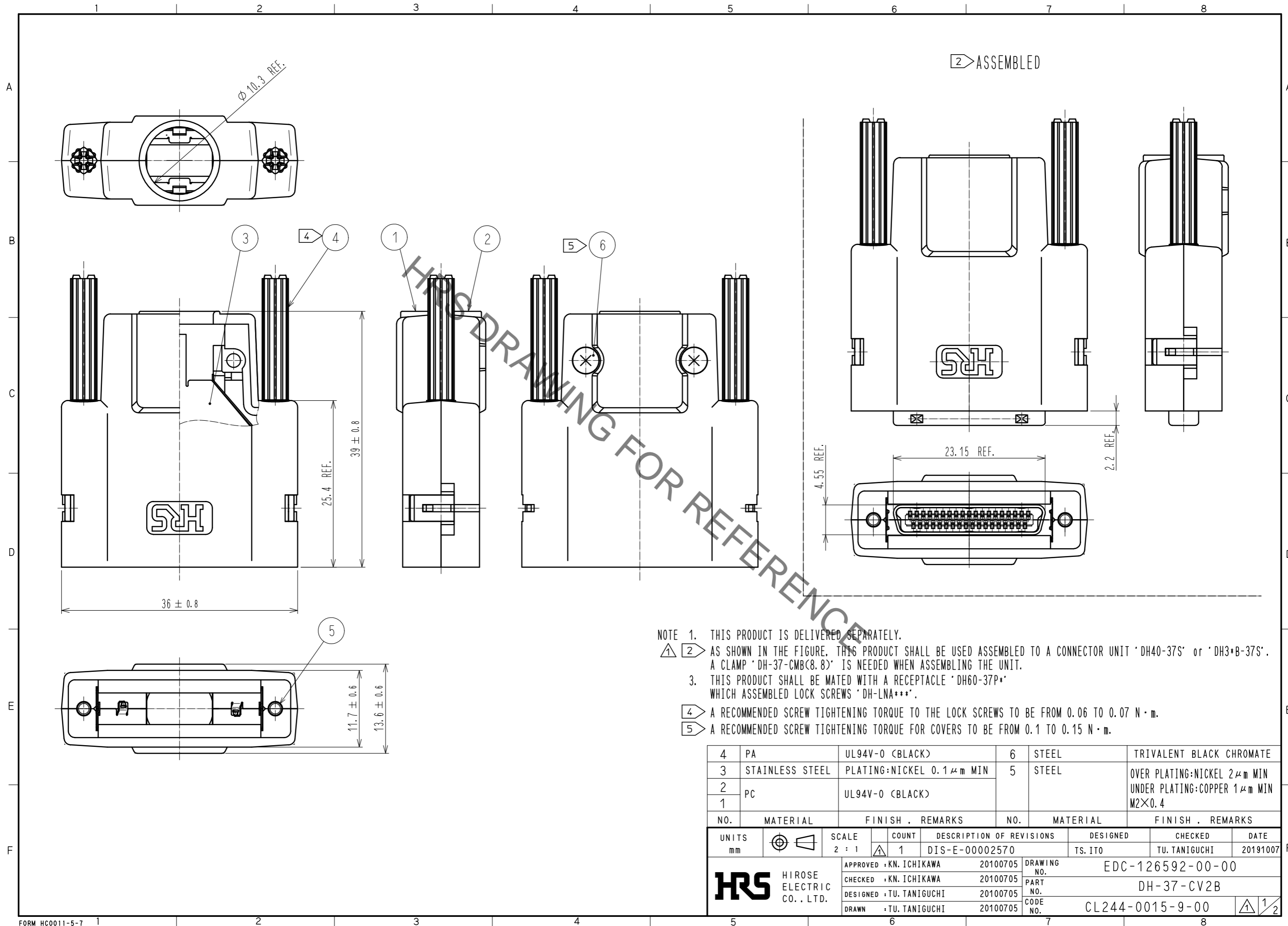

- NOTE 1. THIS PRODUCT IS DELIVERED SEPARATELY.  
 1 2 AS SHOWN IN THE FIGURE, THIS PRODUCT SHALL BE USED ASSEMBLED TO A CONNECTOR UNIT 'DH40-37S' or 'DH3+B-37S'. A CLAMP 'DH-37-CMB(8.8)' IS NEEDED WHEN ASSEMBLING THE UNIT.  
 3. THIS PRODUCT SHALL BE MATED WITH A RECEPTACLE 'DH60-37P\*' WHICH ASSEMBLED LOCK SCREWS 'DH-LNA\*\*\*'.  
 4 A RECOMMENDED SCREW TIGHTENING TORQUE TO THE LOCK SCREWS TO BE FROM 0.06 TO 0.07 N · m.  
 5 A RECOMMENDED SCREW TIGHTENING TORQUE FOR COVERS TO BE FROM 0.1 TO 0.15 N · m.

4	PA	UL94V-0 (BLACK)	6	STEEL	TRIVALENT BLACK CHROMATE
3	STAINLESS STEEL	PLATING:NICKEL 0.1 μm MIN	5	STEEL	OVER PLATING:NICKEL 2 μm MIN UNDER PLATING:COPPER 1 μm MIN
2	PC	UL94V-0 (BLACK)			M2×0.4
1					
NO.	MATERIAL	FINISH . REMARKS	NO.	MATERIAL	FINISH . REMARKS

UNITS mm		SCALE 2 : 1	COUNT 1	DESCRIPTION OF REVISIONS DIS-E-00002570	DESIGNED TS. ITO	CHECKED TU. TANIGUCHI	DATE 20191007
<b>HRS</b> HIROSE ELECTRIC CO., LTD.		APPROVED : KN. ICHIKAWA	20100705	DRAWING NO. EDC-126592-00-00			
		CHECKED : KN. ICHIKAWA	20100705	PART NO. DH-37-CV2B			
		DESIGNED : TU. TANIGUCHI	20100705	CODE NO. CL244-0015-9-00			
		DRAWN : TU. TANIGUCHI	20100705			1/2	

May.1.2023 Copyright 2023 HIROSE ELECTRIC CO., LTD. All Rights Reserved.  
In case of consideration for using Automotive equipment / device which demand high reliability, kindly contact our sales window correspondents.

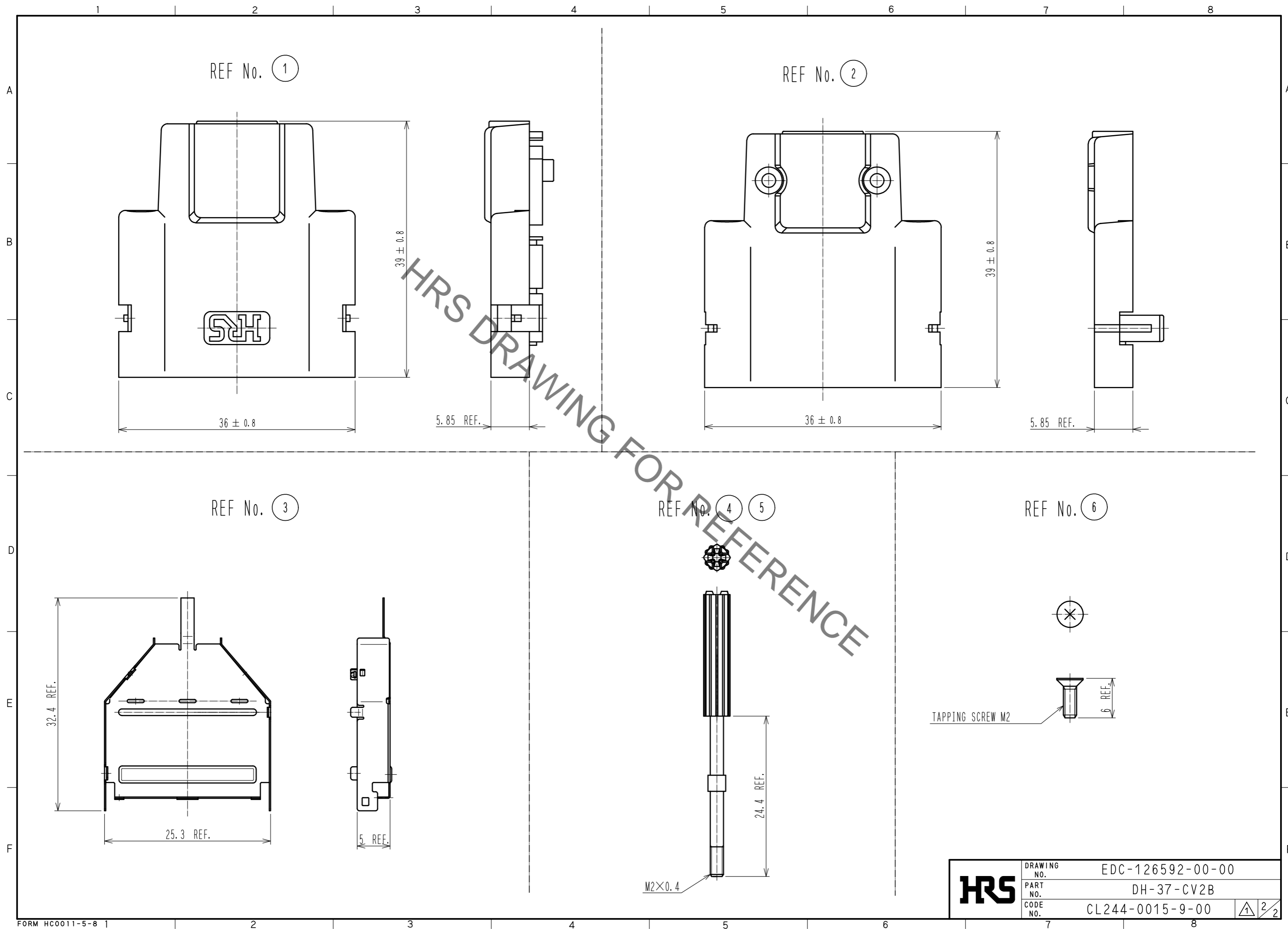

<b>HRS</b>	DRAWING NO.	EDC-126592-00-00
	PART NO.	DH-37-CV2B
	CODE NO.	CL244-0015-9-00
		2/2