

THIS DRAWING IS UNPUBLISHED. RELEASED FOR PUBLICATION
 © COPYRIGHT - By - ALL RIGHTS RESERVED.

REVISIONS				
P	LTR	DESCRIPTION	DATE	APVD
AA1		REVISED PER ECR-19-003911	12MAR2019	BH E.W

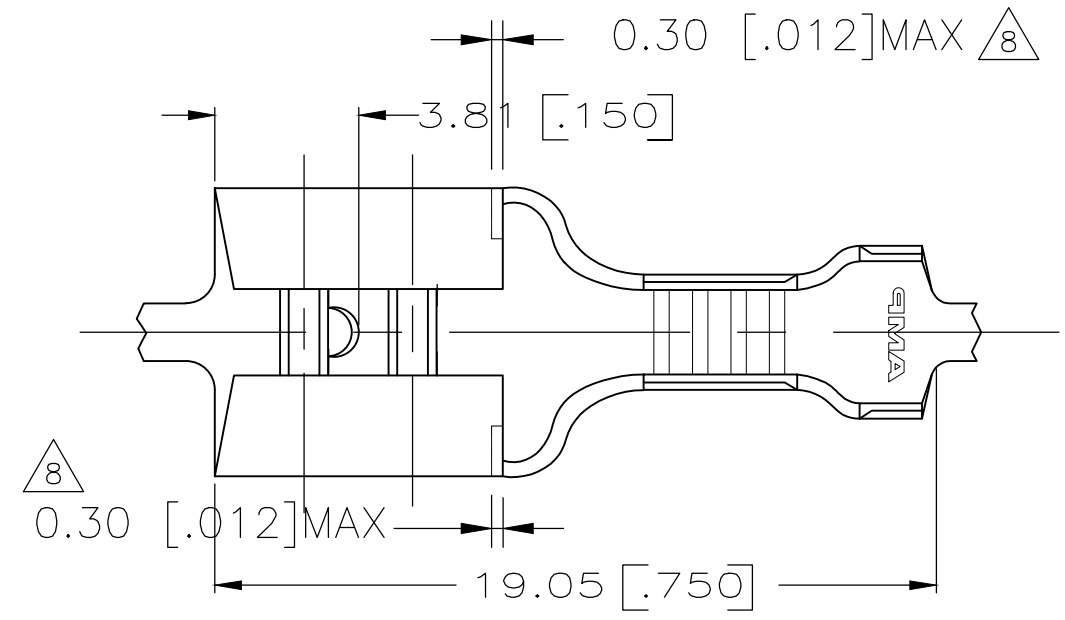

1.52 [.060]
1.27 [.050]

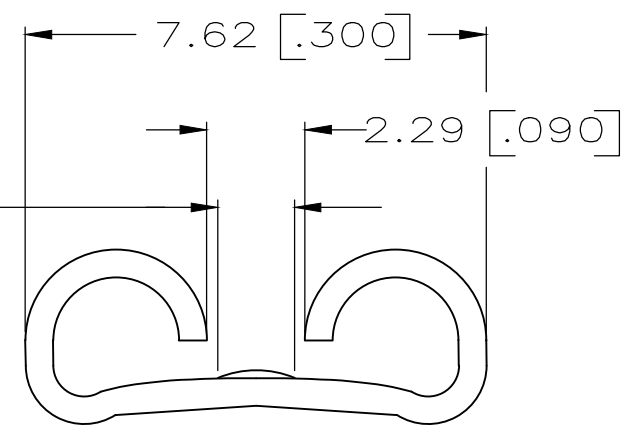

VIEW A-A
SCALE 8:1

$\triangle 8$ CUT-OFF OFFSET IS ALLOWED BY 0.3mm MAX. THIS MAY BE REQUIRED FOR MANUFACTURING, BUT WILL NOT IMPACT THE INTENDED PERFORMANCE OF THE CONTACT.

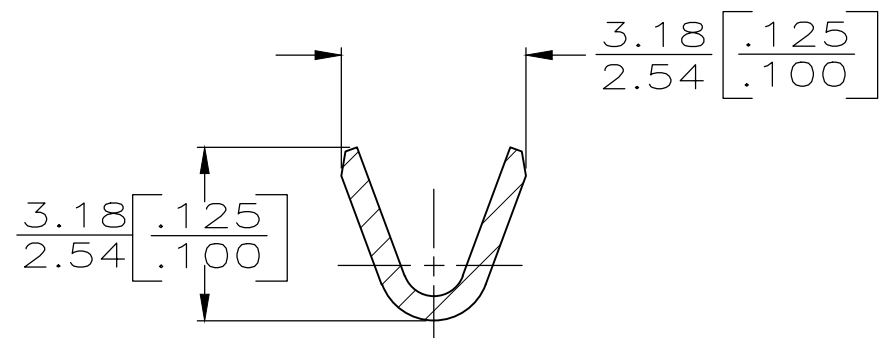
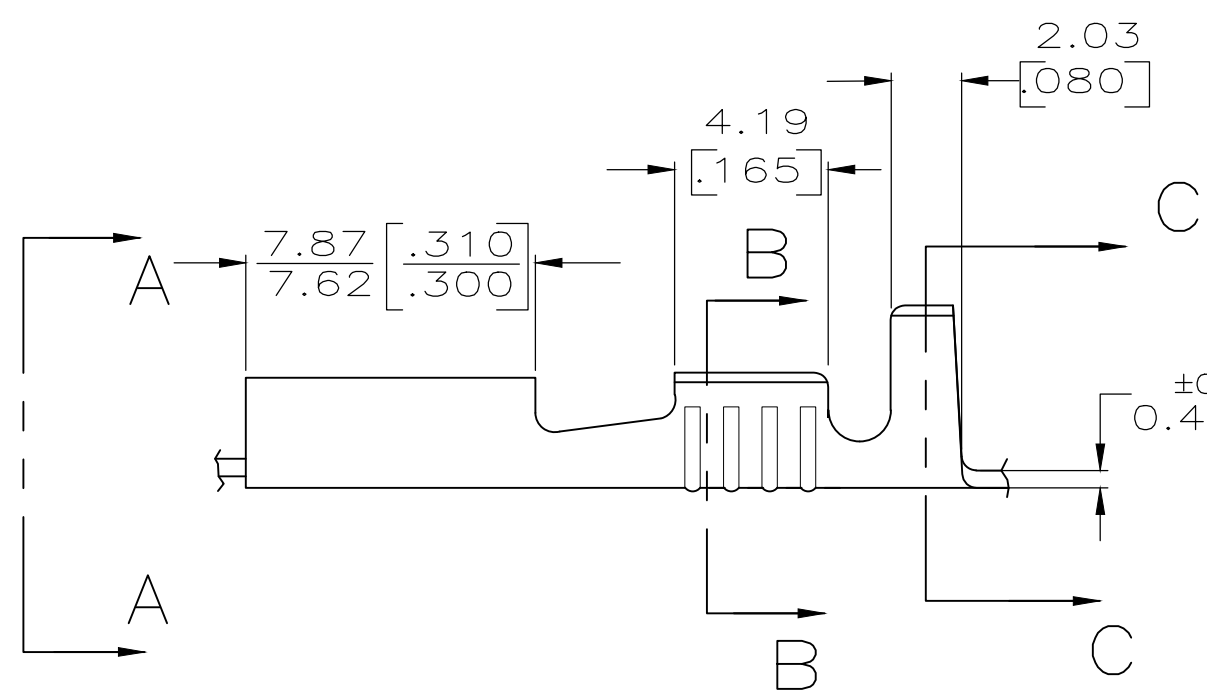

SECTION B-B
SCALE 8:1

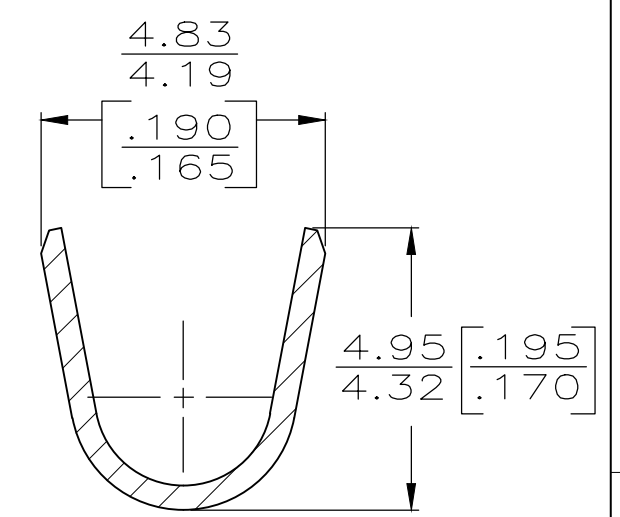

SECTION C-C
SCALE 8:1

- 1 DIMENSIONS IN BRACKETS ARE IN INCHES
- 2 CONTINUOUS STRIP ON REELS
- $\triangle 3$ FOREIGN PRODUCTION ONLY
- $\triangle 4$ FOREIGN PRODUCTION ONLY, INTERLEAVING PAPER REQUIRED
- $\triangle 5$ REELED UPSIDE DOWN WITH INTERLEAVING PAPER.
- $\triangle 6$ PRELIMINARY - NOT FOR PRODUCTION
- $\triangle 7$ FOR AMP ITALY ONLY, NOT STRESS RELIEVED.

2.29-3.30 [.090-.130]	0.3-0.8mm ² [22-18]	±0.025 ±.001 0.81 [.032]	$\triangle 7$ 1-41772-1
			$\triangle 6$ $\triangle 5$ 41772-4
			$\triangle 4$ 41772-3
			$\triangle 3$ 41772-1
			41772
INSUL RANGE	WIRE SIZE	MATING TAB THK	PART NO

THIS DRAWING IS A CONTROLLED DOCUMENT.		DWN JR RUTH 4/26/89	STE TE Connectivity Ltd.				
DIMENSIONS: mm [INCHES]		CHK MS FEHER 4/26/89					
TOLERANCES UNLESS OTHERWISE SPECIFIED:		APVD C MEYERS 4/26/89	NAME RECEPTACLE, FASTON™ .250 SERIES				
<ul style="list-style-type: none"> 0 PLC ± - 1 PLC ± - 2 PLC ± - 3 PLC ± 0.25 [.010] 4 PLC ± - ANGLES ± - 		PRODUCT SPEC -	APPLICATION SPEC				
MATERIAL BRASS		FINISH TIN	114-2036	SIZE A3	CAGE CODE 00779	DRAWING NO C-41772	RESTRICTED TO -
CUSTOMER DRAWING			WEIGHT 0	SCALE 5:1	SHEET 1 OF 1	REV AA1	