

May.1.2023 Copyright 2023 HIROSE ELECTRIC CO., LTD. All Rights Reserved.
 In case of consideration for using Automotive equipment / device which demand high reliability, kindly contact our sales window correspondents.

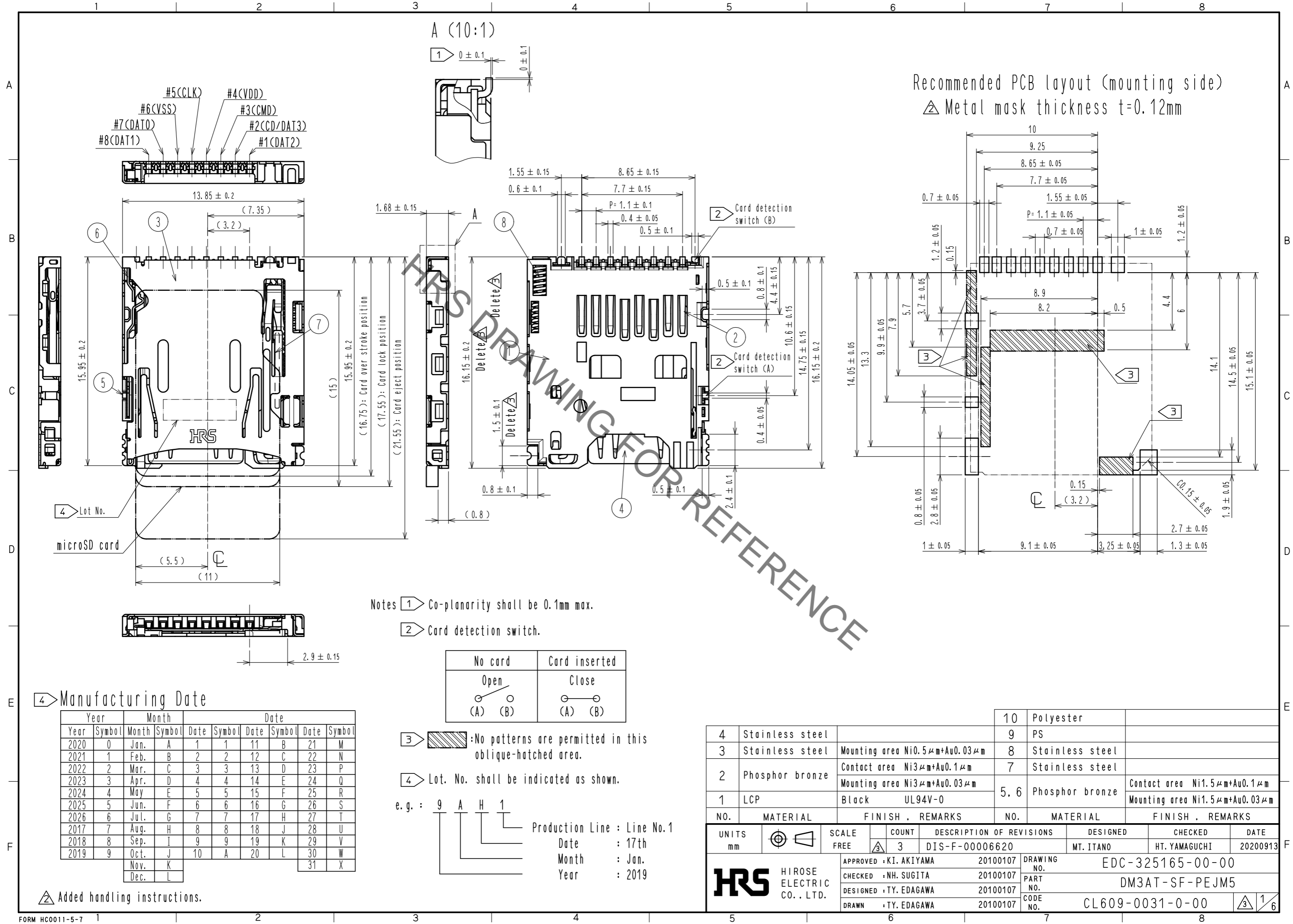

4 Manufacturing Date

Year	Symbol	Month	Symbol	Date	Symbol	Date	Symbol	Date	Symbol
2020	0	Jan.	A	1	1	11	B	21	M
2021	1	Feb.	B	2	2	12	C	22	N
2022	2	Mar.	C	3	3	13	D	23	P
2023	3	Apr.	D	4	4	14	E	24	Q
2024	4	May	E	5	5	15	F	25	R
2025	5	Jun.	F	6	6	16	G	26	S
2026	6	Jul.	G	7	7	17	H	27	T
2017	7	Aug.	H	8	8	18	J	28	U
2018	8	Sep.	I	9	9	19	K	29	V
2019	9	Oct.	J	10	A	20	L	30	W
		Nov.	K						
		Dec.	L						

No card		Card inserted	
Open		Close	
(A) (B)		(A) (B)	

NO.	MATERIAL	FINISH	REMARKS	NO.	MATERIAL	FINISH	REMARKS
4	Stainless steel			10	Polyester		
3	Stainless steel	Mounting area Ni0.5 μm +Au0.03 μm		8	Stainless steel		
2	Phosphor bronze	Contact area Ni3 μm +Au0.1 μm		7	Stainless steel		
1	LCP	Black UL94V-0		5, 6	Phosphor bronze	Contact area Ni1.5 μm +Au0.1 μm	
						Mounting area Ni1.5 μm +Au0.03 μm	

UNITS	SCALE	COUNT	DESCRIPTION OF REVISIONS	DESIGNED	CHECKED	DATE
mm	FREE	3	DIS-F-00006620	MT. ITANO	HT. YAMAGUCHI	20200913

APPROVED	CHECKED	DESIGNED	DRAWN	DRAWING NO.	PART NO.	CODE NO.
•KI. AKIYAMA	•NH. SUGITA	•TY. EDAGAWA	•TY. EDAGAWA	EDC-325165-00-00	DM3AT-SF-PEJM5	CL609-0031-0-00

May.1.2023 Copyright 2023 HIROSE ELECTRIC CO., LTD. All Rights Reserved.
In case of consideration for using Automotive equipment / device which demand high reliability, kindly contact our sales window correspondents.

5 Drawing for packing (2:1)

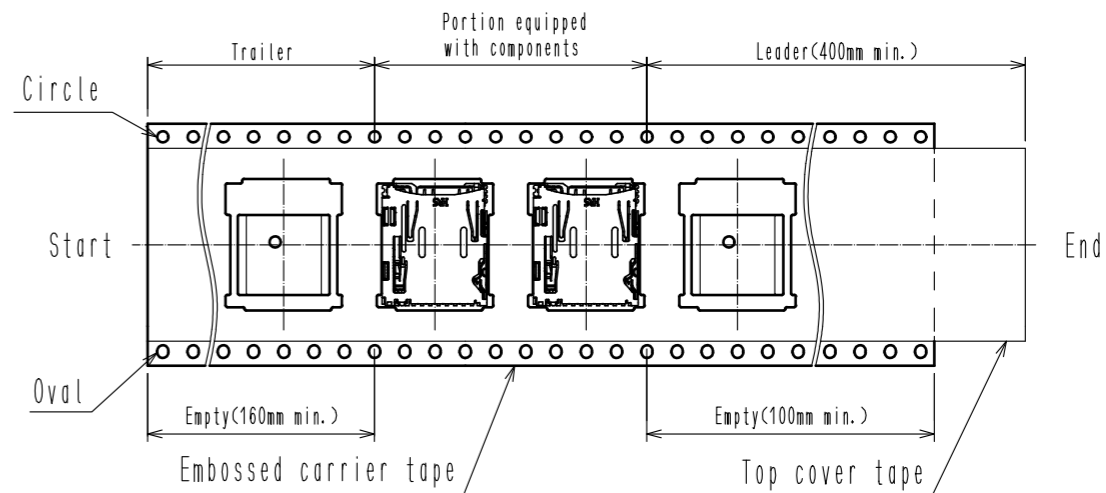
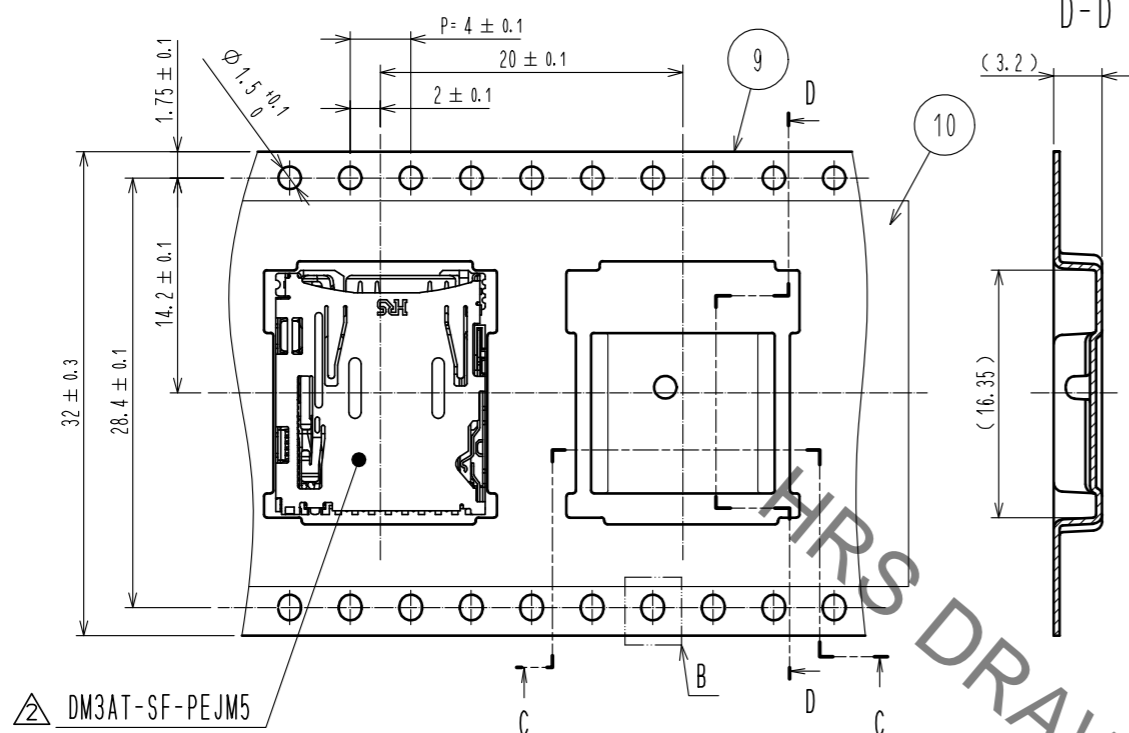

Unreeling direction

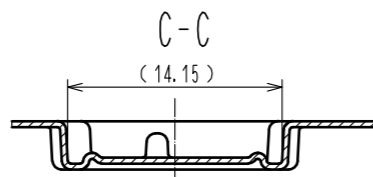

B (10:1)

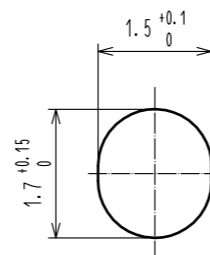

Recommended temperature profile

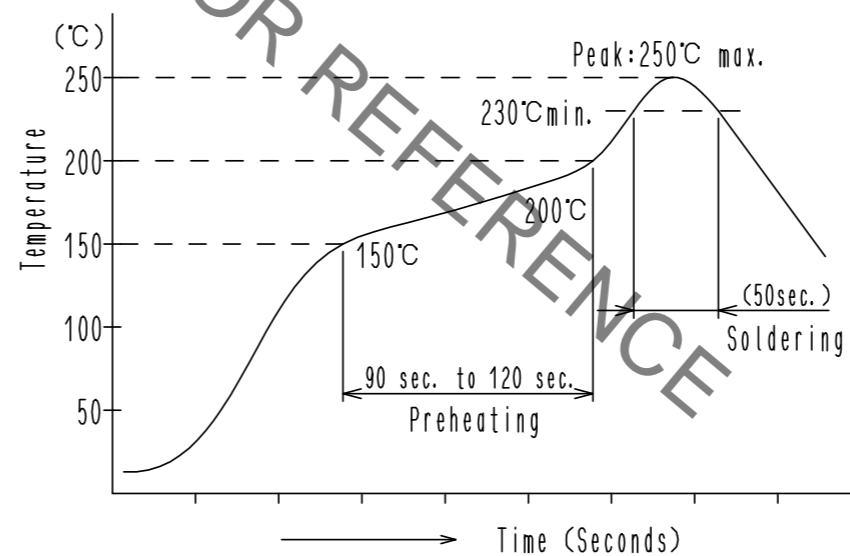

<Conditions>

- Reflow method : Combined far-IR and hot-air reflow
- Reflow atmosphere : Ambient air
- Solder : Cream type Sn/3.0Ag/0.5Cu
(M705-GRN360-K2-V made by Senju Kinzoku)
- Board tested : 60×100×1mm glass epoxy
- Metal mask thickness : 0.12mm
- Number of reflow cycles : Two cycles max

This temperature profile applies to the conditions stated above. Since temperature profiles can vary depending on the type and manufacturer of the cream solder used, as well as board size and other factors including conditions of the parts to be mounted, make sure to check the mounting conditions carefully before use.

Notes 5 Packing type: TAPE and REEL. 1500PCS per REEL.

(Delete note)

HRS	DRAWING NO.	EDC-325165-00-00
	PART NO.	DM3AT-SF-PEJM5
	CODE NO.	CL609-0031-0-00

3/2/6

May.1.2023 Copyright 2023 HIROSE ELECTRIC CO., LTD. All Rights Reserved.
 In case of consideration for using Automotive equipment / device which demand high reliability, kindly contact our sales window correspondents.

△ [Product information and handling instructions]

1. Contact timing

● Follow the following contact timing chart.

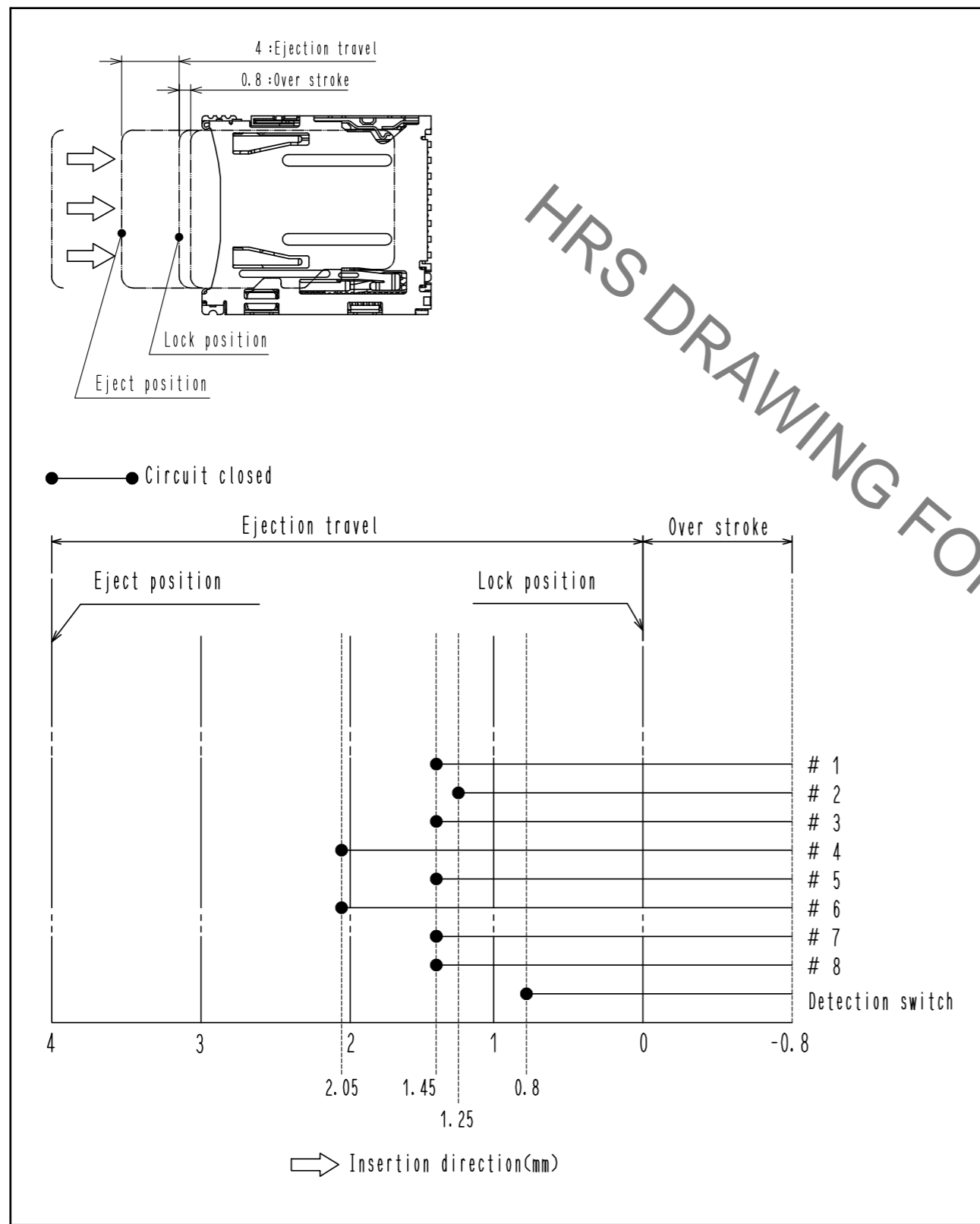

2. Area recommended for the application of surface mounting adhesive

● Make sure to apply adhesives in the applicable areas shown in the drawing below. Avoid the use of adhesives in other areas as this can lead to functional problems. Do not apply excessive amounts of adhesive as this can cause the product to "float" which may in turn cause solder failure. Make sure to use only the smallest amount of adhesive possible.

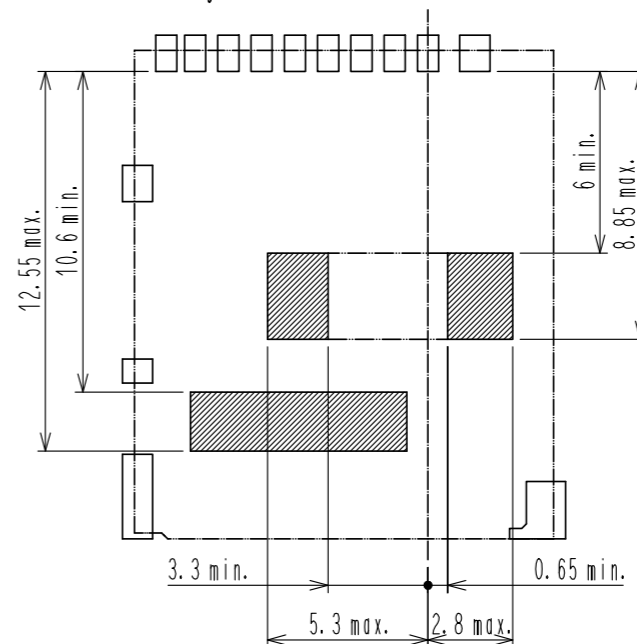

Recommended adhesive:
 SOMAKOTE IR-010H-3
 (made by Somar Corp.)

3. Attachable area on the upper side

● The shaded area shown in the drawing below designates the area where the product can be pressed on from the upper side using the enclosure.

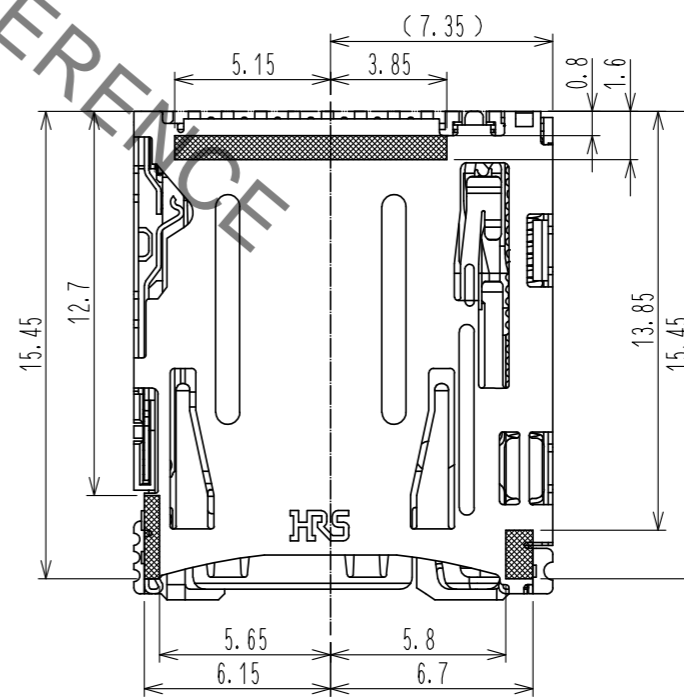

HRS	DRAWING NO.	EDC-325165-00-00
	PART NO.	DM3AT-SF-PEJM5
	CODE NO.	CL609-0031-0-00
		3/6

May.1.2023 Copyright 2023 HIROSE ELECTRIC CO., LTD. All Rights Reserved.
 In case of consideration for using Automotive equipment / device which demand high reliability, kindly contact our sales window correspondents.

4. Recommended enclosures

● Recommended enclosure dimensions

For better card insertability, we recommend enclosure dimensions as shown below.

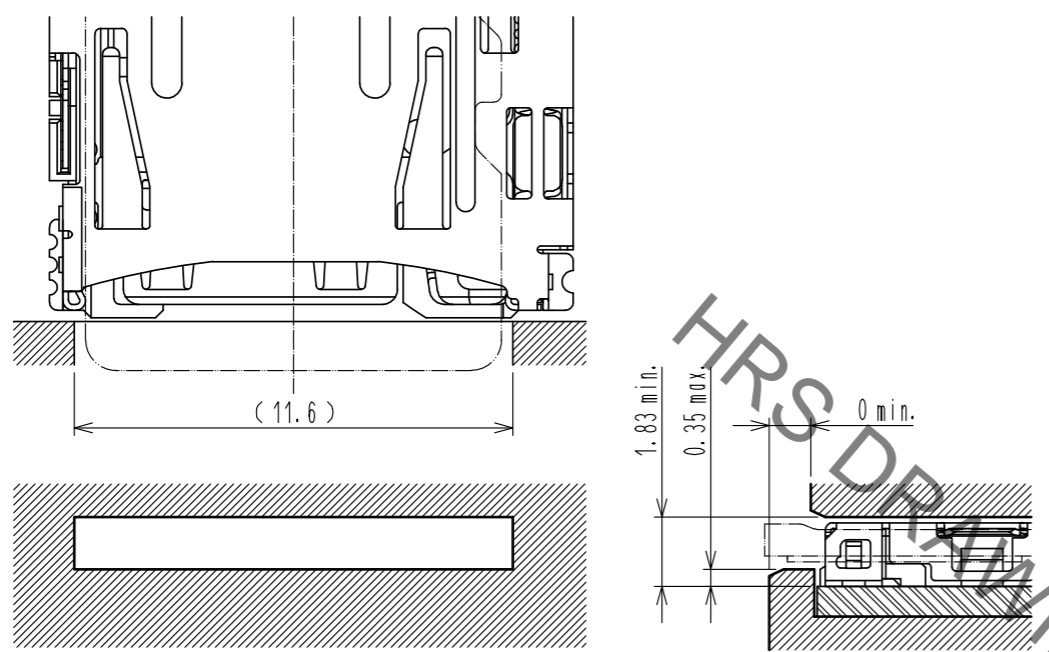

● Recommended finger indent

We recommend that you design your enclosure with a “finger indent” as shown in the drawing below to facilitate card withdrawal.
 If the center point of the finger indent must be placed off-center of the card, it may be off-center only in the direction shown in the first example shown below. This is to prevent the card from being inserted or withdrawn at an angle.

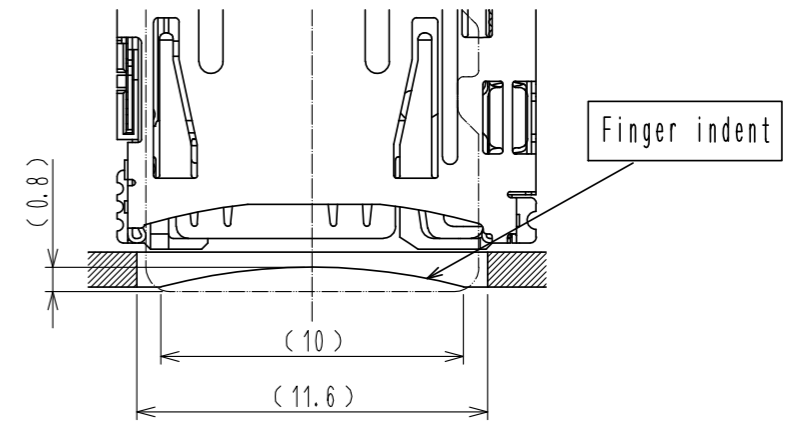

● Recommended dimensions for attaching a cover (lid)

Please install a cover (lid) to prevent the card from falling or becoming misplaced due to unforeseen causes.
 The following dimensions are recommended for attaching a cover (lid).

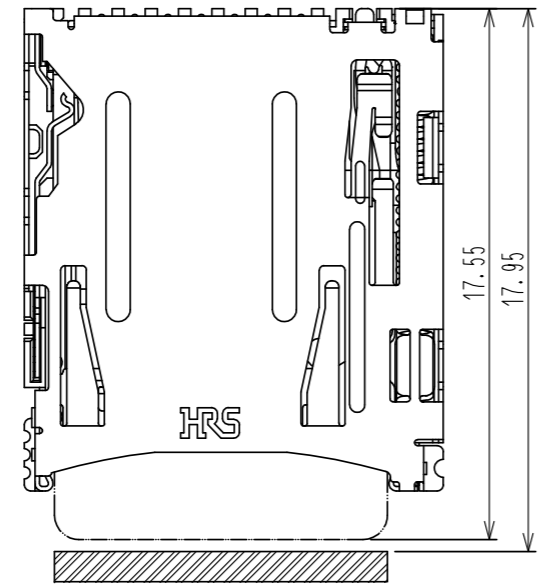

○ Off-centering allowed

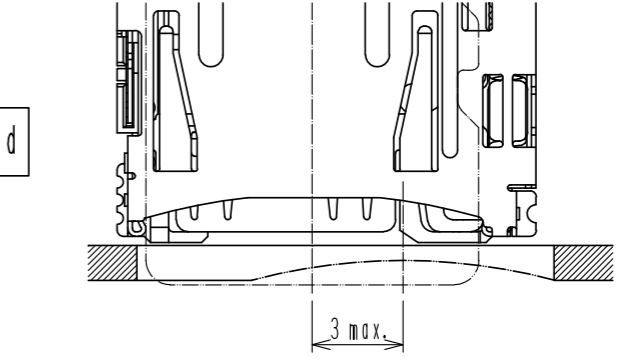

× No off-centering allowed

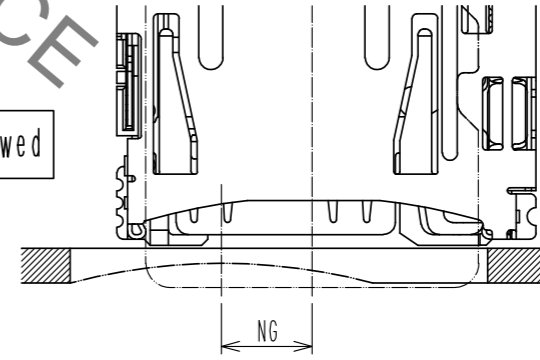

● Markings for preventing incorrect card insertion

If you will be displaying markings or instructions to prevent end users from inserting the card incorrectly, please pay extra attention to the text description and the direction of the marking used to indicate the correct direction.

HRS	DRAWING NO.	EDC-325165-00-00	
	PART NO.	DM3AT-SF-PEJM5	
	CODE NO.	CL609-0031-0-00	
			3/4/6

May.1.2023 Copyright 2023 HIROSE ELECTRIC CO., LTD. All Rights Reserved.
In case of consideration for using Automotive equipment / device which demand high reliability, kindly contact our sales window correspondents.

5. Reminders

- (1) This product is equipped with an ejection function.
Never wash the entire connector as this could lead to problems with this function.
If it must be washed, wash only the soldered areas and make sure that you do not leave any cleaner residues on the connector. Cleaner residues can cause problems with card insertion/extraction and electrical performance.
- (2) You may find some processing liquid residue on the surface of the product but this has no effect on its quality.
- (3) If you will be performing card recognition and operating inspections in your assembly process, please pay attention to the points listed below.
If any of these points do not meet requirements, use a new card to perform your inspections.
 - Outer dimensions must be within specifications. Pay particular attention not to use products that have become off-spec due to wear.
 - Make sure that there is no severe wear on the pad (base material must not be exposed).

- (4) Excessive force may cause the connector to fail or become damaged.
Please handle the connector with care and make sure that it does not deform in any way. In particular, avoid the following if you will be performing card recognition and operating inspections in your assembly process without installing the product to an enclosure.
 - Do not insert or withdraw cards at an angle, whether in a vertical or lateral direction.
 - Do not insert or withdraw a partially inserted card by prying it in a vertical or lateral direction.

Important outer dimensions
for microSD CARD standard

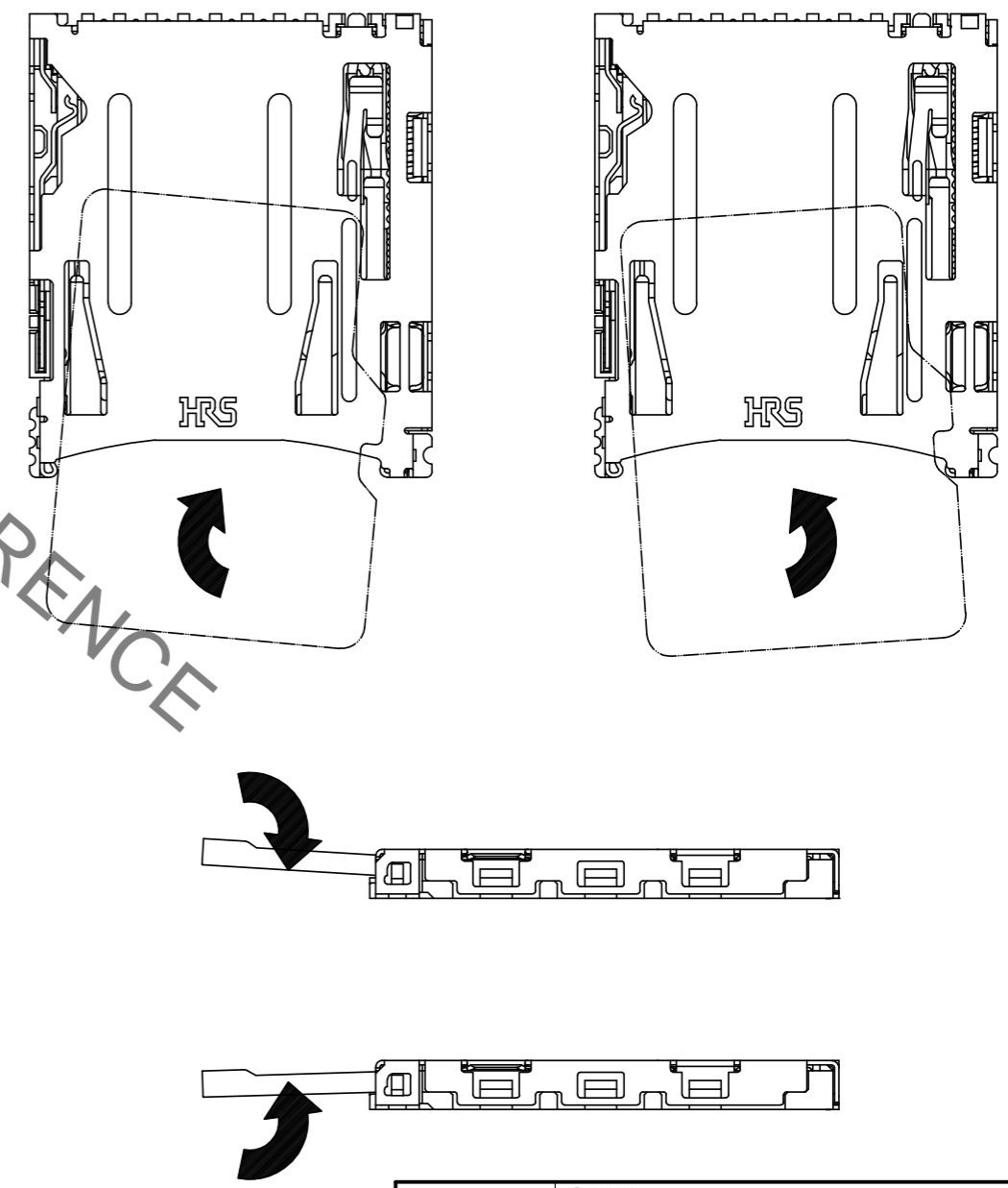
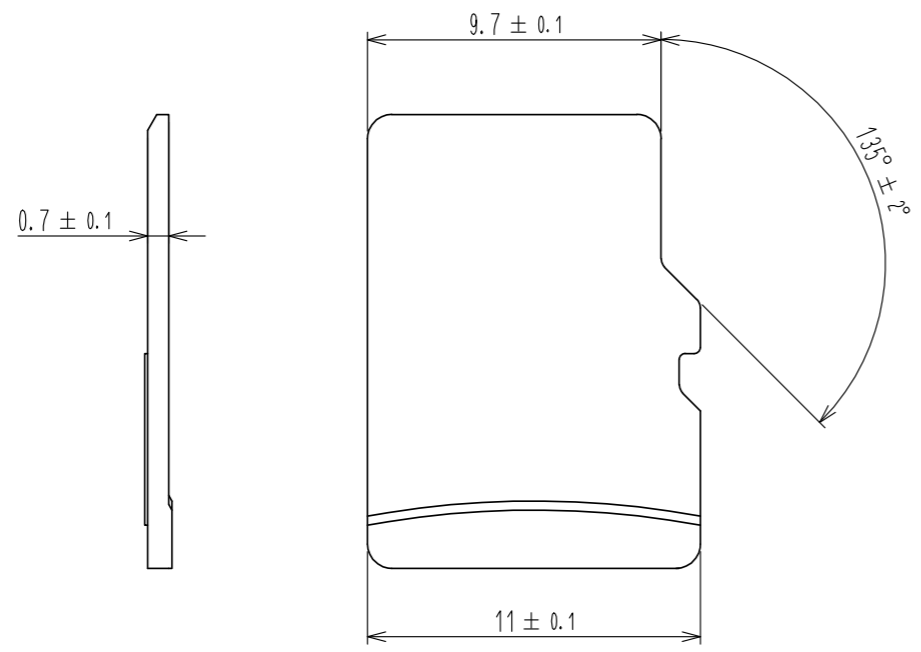

HRS	DRAWING NO.	EDC-325165-00-00
	PART NO.	DM3AT-SF-PEJM5
	CODE NO.	CL609-0031-0-00
		5/6

May.1.2023 Copyright 2023 HIROSE ELECTRIC CO., LTD. All Rights Reserved.
In case of consideration for using Automotive equipment / device which demand high reliability, kindly contact our sales window correspondents.

(5) Movable parts: The tip of the ejector may be slightly slanted as shown in the drawing but this has no effect on its performance.

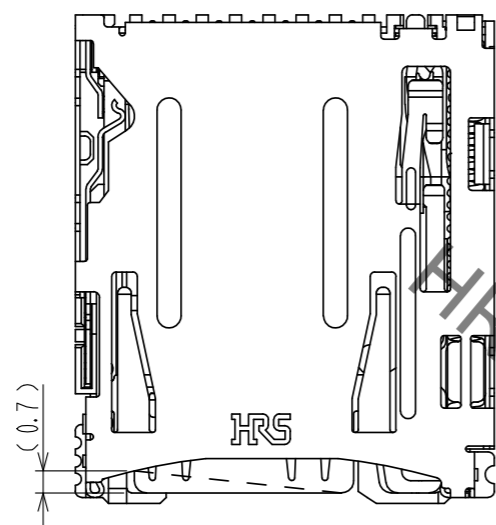

(6) The connector's detection contact is exposed due to its low profile design. Please handle with care.

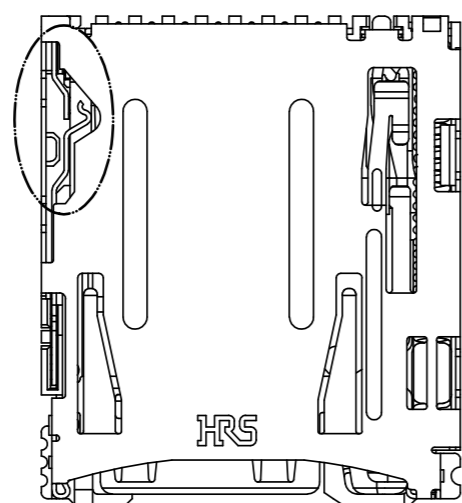

(7) This is a connector designed to be mounted on boards. Make sure not to use the connector on its own as this could lead to functional problems.

(8) This is a connector for microSD/TransFlash cards. Do not insert other types of cards. Make sure not to insert the card in the wrong direction, at an angle, or forcibly. This product is equipped with a function for preventing users from inserting cards in the wrong direction, but damage may occur to the card and/or connector if the card is forcibly inserted in the wrong direction.

(9) Please do not use a prying motion to withdraw an engaged card. This can cause damage to the card and/or connector.

(10) Due to the material used, the surface of a card will be subject to sliding scratches but this will not affect product quality or performance.

(11) Cards are designed to withstand a bending strength of up to 10N. Please handle cards with care to prevent damage.

HIRS DRAWING FOR REFERENCE

HIRS	DRAWING NO.	EDC-325165-00-00			
	PART NO.	DM3AT-SF-PEJM5			
	CODE NO.	CL609-0031-0-00			
			3	6	6