

May.1.2023 Copyright 2023 HIROSE ELECTRIC CO., LTD. All Rights Reserved.
In case of consideration for using Automotive equipment / device which demand high reliability, kindly contact our sales window correspondents.

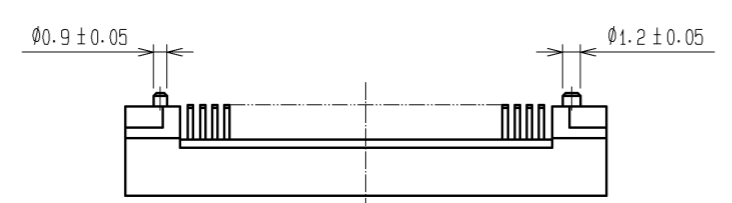

A-A (10:1)

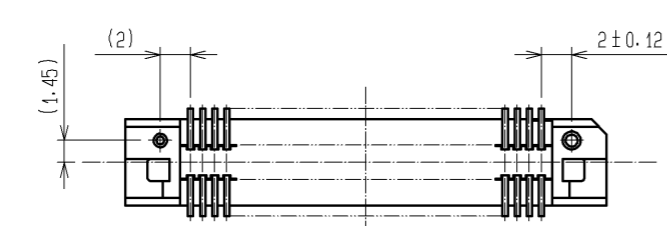
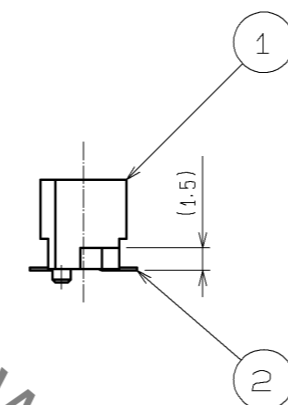
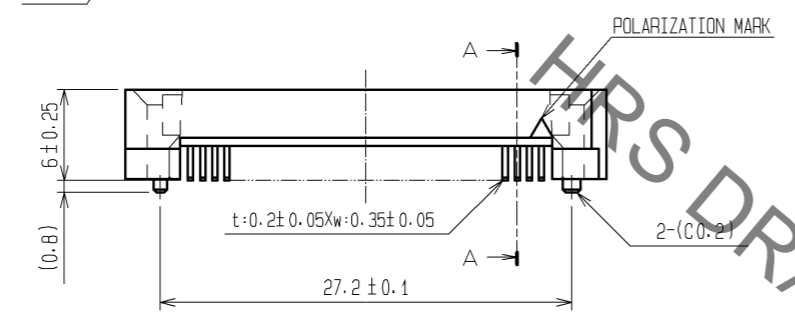
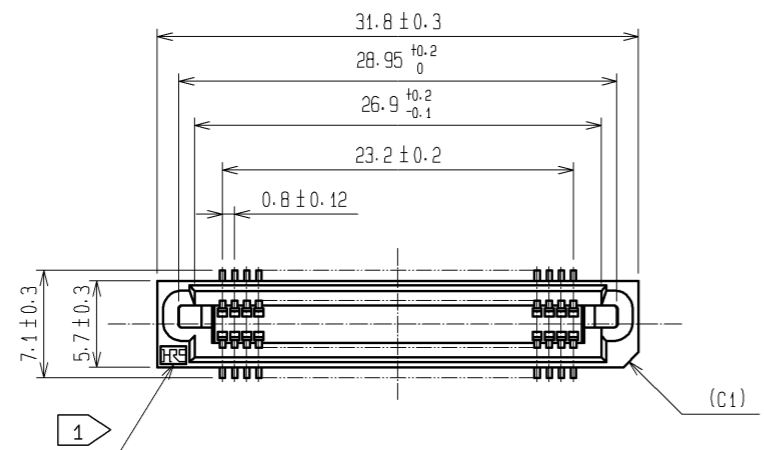
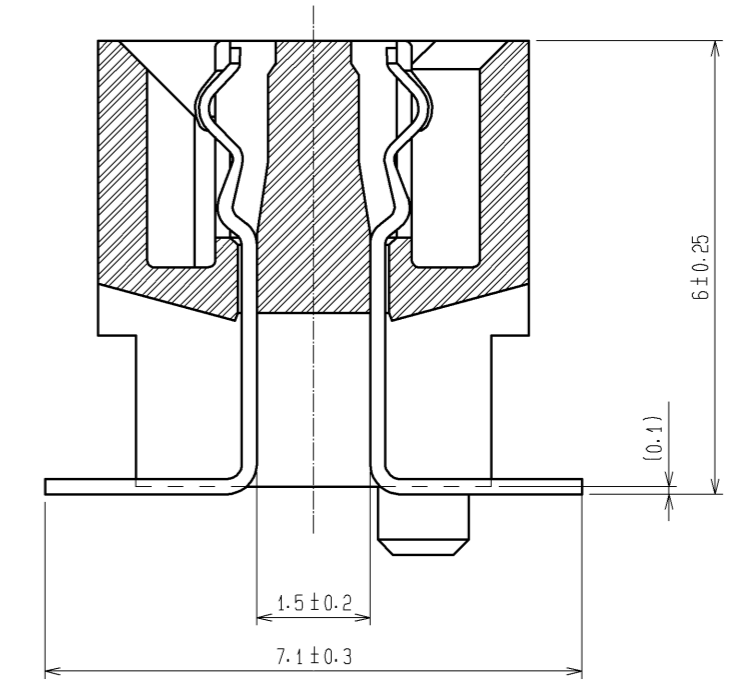

- NOTE
- 1 IRIS MARK SHALL BE OPTIONAL.
 - 2 LEAD CO-PLANARITY SHALL BE 0.1mm MAX.
 - 3 TUBE PACKAGING SHALL BE APPLIED FOR THIS PRODUCT. SEE NEXT PAGE FOR DETAILS.
 - 4 THIS PRODUCT HAS TAPE FOR VACUUM PICKUP. SEE NEXT PAGE FOR DETAIL OF STICKING POSITION, ETC.
 - 5 FOR MODIFICATION, ETC, PREVENTIVE HOLE FOR SINK MARK MAY BE ADDED ACCORDING TO CIRCUMSTANCES.
 - 6 THE DIMENSIONS IN PARENTHESES ARE FOR REFERENCE.

RECOMMENDED LAND PATTERN DIMENSION OF PCB (MOUNTING SIDE)
(RECOMMENDED METAL MASK THICKNESS: 0.15mm)

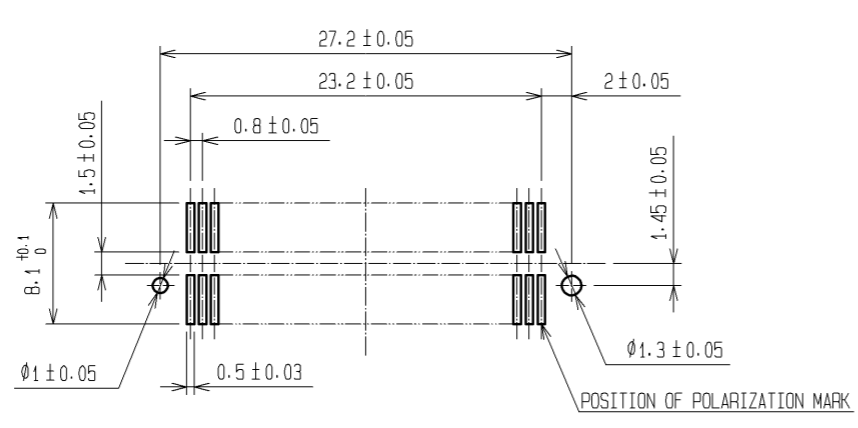

2	PHOSPHOR BRONZE	CONTACT AREA: GOLD 0.1µm min.						
		LEAD AREA: TIN-PLATING 1µm min.						
		UNDER PLATING: NICKEL 2µm min.						
1	PPS	LIGHT BROWN (UL94V-0)	5	POLYIMIDE	(TAPE FOR VUCUUM PICKUP)			
			4	PVC	(STOPPER)			
			3	PVC	(TUBE)			
NO.	MATERIAL	FINISH . REMARKS	NO.	MATERIAL	FINISH . REMARKS			
UNITS mm		SCALE 2 : 1	COUNT 	DESCRIPTION OF REVISIONS		DESIGNED	CHECKED	DATE
HRS HIROSE ELECTRIC CO., LTD.		APPROVED : HS. OKAWA	08.07.23	DRAWING NO.		EDC3-084982-21		
		CHECED : HT. YAMAGUCHI	08.07.23	PART NO.		FX6-60S-0.8SV2(91)		
		DESIGNED : SY. KAMIGA	08.07.22	CODE NO.		CL576-0125-6-91		
		DRAWN : HK. SUNADORI	08.07.18			1/2		

May.1.2023 Copyright 2023 HIROSE ELECTRIC CO., LTD. All Rights Reserved.
In case of consideration for using Automotive equipment / device which demand high reliability, kindly contact our sales window correspondents.

DRAWING FOR PACKING(FREE)

550⁰₋₂

(14)

5

(8.6)

(10.2)

HRS DRAWING FOR REFERENCE

POLARIZATION MARK

MARKING

FX6 S SV2

3

4

DETAIL FOR TAPE FOR VACUUM PICK-UP(5:1)

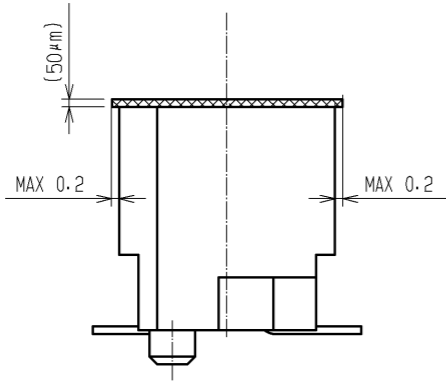

- NOTE 1 THE DIMENSIONS IN PARENTHESES ARE FOR REFERENCE.
2 ONE TUBE CONSISTS OF 16 PIECES.
3 REMOVE THE VACUUM PICK-UP TAPE AFTER MOUNTING THE CONNECTOR.

HRS	DRAWING NO.	EDC3-084982-21
	PART NO.	FX6-60S-0.8SV2(91)
	CODE NO.	CL576-0125-6-91
		△ 2/2