

© 1953 BY AMP INCORPORATED. ALL RIGHTS RESERVED. AMP PRODUCTS COVERED BY PATENTS AND/OR PATENTS PENDING.

REVISIONS				
ZONE	DATE	DESCRIPTION	DATE	APPROVED
C	1-5-70	REDRAWN & REVISED P-5563 SK		Jme
D	8-17-70	ADDED 2-322006-2 NPS 68-0656 (REI. 2)		Jme
E	3-15-70	REVISED REVISION D	JDL	FCY
F	6-7-73	INACTIVATED 2-322006-1 P-7054 TP		Jme
G	11/23/79	REV PER ECN P-7000	RB.	-1-m
H	3-1-82	OBSOLETE 2-1 P-9222	DDT	JSM
J	5-6-80	REV G-4680	TMS	JT
K	10/25/88	OBS. 2-2 PFR G-2693	JT	JT
L	4-6-93	REV/0720-0060-93		TO /ml

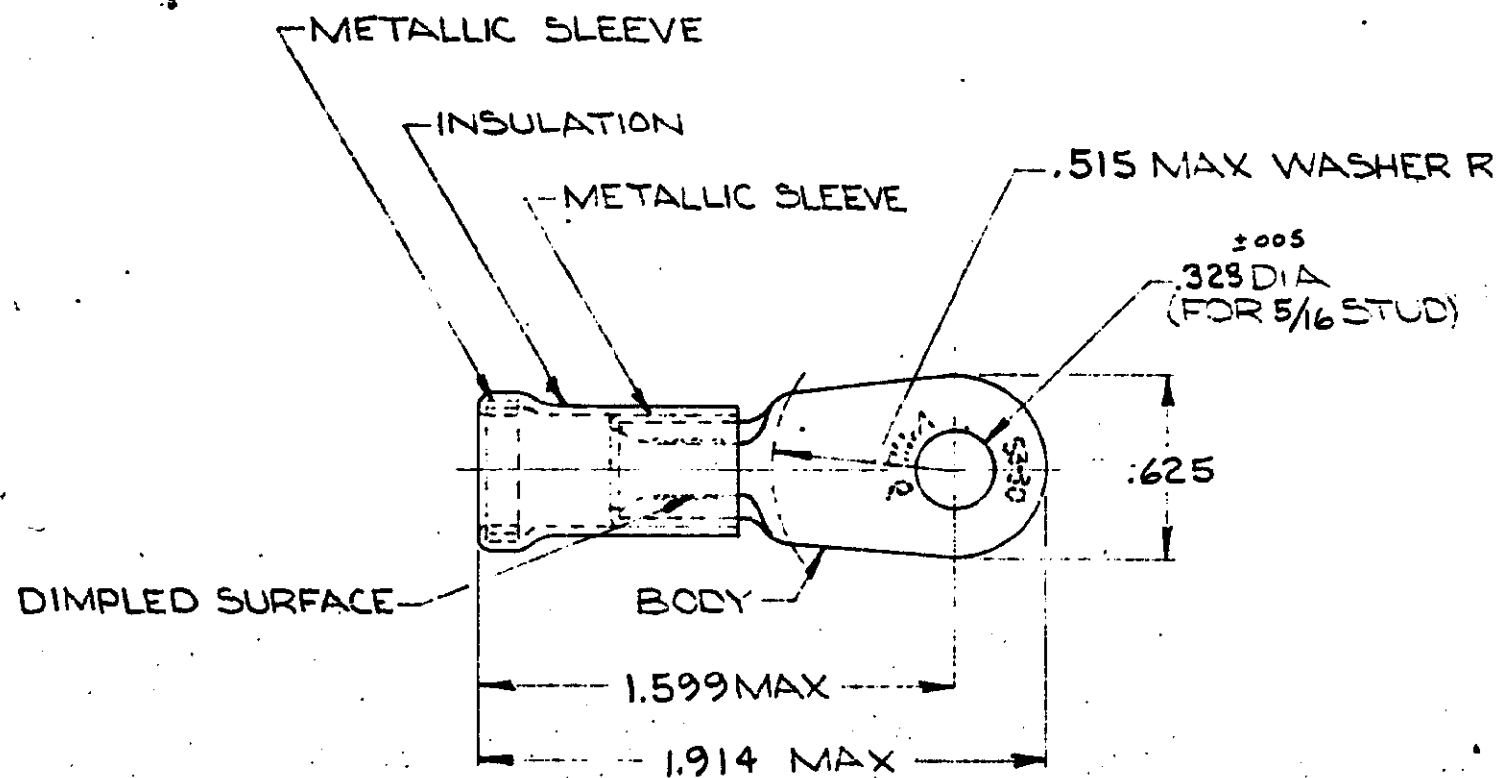

TONGUE MATERIAL THICKNESS = .045 ±.003
FOR "A" MAX WIRE INS DIA

TABLE I

20	LOOSE PC. BOX	8-322006-5	BODY: COPPER (QQ-C-576) FINISH: (SEE TABLE II) INSULATION: PVC COLOR: BLUE METALLIC SLEEVE: COPPER (QQ-C-576) METALLIC BAND: STEEL QQ-S-698 (ASTM A109)
1	WIRE TERMINAL	SEE TABLE II	
QTY	DESCRIPTION	PART NO.	MATERIAL & FINISH
UNLESS OTHERWISE SPECIFIED DIMENSIONS ARE IN INCHES TOLERANCES ON: DECIMALS ±.008 ANGLES ±.5°			CONTRACT NO. —
MATERIAL			DR. <i>J. Kautz</i> 11-14-69
SEE TABLE I			CHK. <i>M. E. ...</i> 1-5-70
			APPD. <i>L. W. ...</i> 1-7-70
			REL. <i>M. E. ...</i> 1-8-70
			DSGN APPD. <i>J.</i>
			OTHER APPD.
AMP		AMP INCORPORATED HARRISBURG, PENNSYLVANIA	
NAME: -WIRE TERMINAL AMPLI-BOND - RING TONGUE WIRE SIZE: 6			
SIZE	CODE IDENT NO.	NUMBER	
B	00779	322006	
SCALE NTS		SHEET 1 OF 1	

TABLE II

PART NO.	FINISH	"A"	PART NO. ON TUBE
8-322006-5	TIN PL (MIL-T-10727)	.377	
2-322006-2	TIN PL (MIL-T-10727)	.436	OBSOLETE
2-322006-1	GOLD PL. (MIL-G-45204) TYPE II 00005 MIN EXT THK OVER		OBSOLETE
	NICKEL PL (QQ-N-290) 00003 MIN. EXT. THK.	.377	
322006	TIN PL (MIL-T-10727)		2-322006-3
PART NO.	FINISH	"A"	PART NO. ON TUBE