

OUTLINE DIMENSIONS

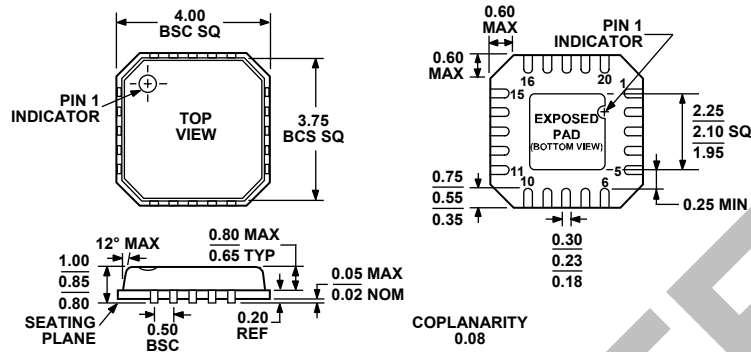

Figure 33. 20-Lead Frame Chip Scale Package [LFCSP_VQ]
4 mm × 4 mm Body, Very Thin Quad
(CP-20-1)
Dimensions shown in millimeters

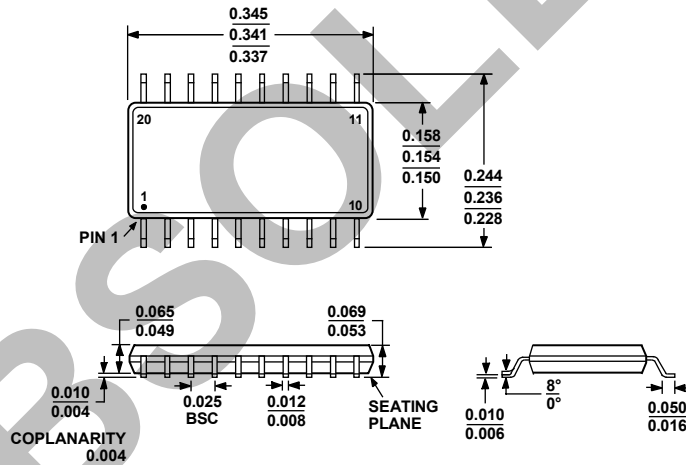

Figure 34. 20-Lead Shrink Small Outline Package [QSOP]
(RQ-20)
Dimensions shown in inches

AD8328

ORDERING GUIDE

Model	Temperature Range	Package Description	Package Option
AD8328ARQ	-40°C to +85°C	20-Lead QSOP	RQ-20
AD8328ARQ-REEL	-40°C to +85°C	20-Lead QSOP	RQ-20
AD8328ARQZ ¹	-40°C to +85°C	20-Lead QSOP	RQ-20
AD8328ARQZ-REEL ¹	-40°C to +85°C	20-Lead QSOP	RQ-20
AD8328ACP	-40°C to +85°C	20-Lead LFCSP_VQ	CP-20-1
AD8328ACP-REEL	-40°C to +85°C	20-Lead LFCSP_VQ	CP-20-1
AD8328ACP-REEL7	-40°C to +85°C	20-Lead LFCSP_VQ	CP-20-1
AD8328ACPZ ¹	-40°C to +85°C	20-Lead LFCSP_VQ	CP-20-1
AD8328ACPZ-REEL ¹	-40°C to +85°C	20-Lead LFCSP_VQ	CP-20-1
AD8328ACPZ-REEL7 ¹	-40°C to +85°C	20-Lead LFCSP_VQ	CP-20-1
AD8328ACP-EVAL		Evaluation Board	
AD8328ARQ-EVAL		Evaluation Board	

¹ Z = Pb-free part.

NOTES

OBSOLETE

AD8328

NOTES

OBSOLETE