

Fig.1 Recommended spacer height (Free)

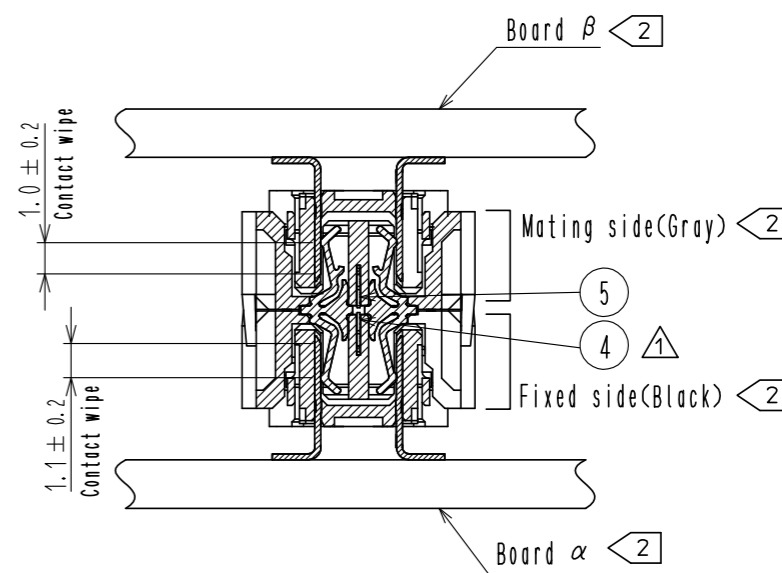

Fig.2 Mating cross section (Free)

Table.1 Stacking height and connector combinations 1

Board distance (Stacking height)	Header connector of Board $\alpha$	Interposer	Header connector of Board $\beta$	Recommended spacer height(L) <span style="border: 1px solid black; padding: 1px;">3</span>
8mm	FX10A-120P-SV(**)	FX10-120IP-36Q-8H(03)	FX10A-120P-SV(**)	8±0.127mm
9mm	FX10A-120P-SV1(**)		FX10A-120P-SV(**)	9±0.127mm
10mm	FX10A-120P-SV1(**)		FX10A-120P-SV1(**)	10±0.127mm

Table.2 Pin configuration of Interposer 4

Row A Pin No.	1	2	3	4	5	6	7	8	9	10	11	12	13	14	15	16	17	18	19	20	21	22	23	24	25	26	27	28	29	30	31	32	33	34	35	36	37	38	39	40	41	42	43	44	45	46	47	48	49	50	51	52	53	54	55	56	57	58	59	60
Pin configuration	G1	S	S	G1	S	S	G1	S	S	G1	S	S	G1	S	S	G1	S	S	G1	S	S	G1	S	S	G1	S	S	G1	SE	SE	SE	SE	G2	S	S	G2	S	S	G2	S	S	G2	S	S	G2	S	S	G2	S	S	G2	S	S	G2	S	S	G2	S	S	G2
Row B Pin No.	1	2	3	4	5	6	7	8	9	10	11	12	13	14	15	16	17	18	19	20	21	22	23	24	25	26	27	28	29	30	31	32	33	34	35	36	37	38	39	40	41	42	43	44	45	46	47	48	49	50	51	52	53	54	55	56	57	58	59	60
Pin configuration	G1	S	S	G1	S	S	G1	S	S	G1	S	S	G1	S	S	G1	S	S	G1	S	S	G1	S	S	G1	S	S	G1	SE	SE	SE	SE	G2	S	S	G2	S	S	G2	S	S	G2	S	S	G2	S	S	G2	S	S	G2	S	S	G2						

S: Signal for Differential SE: Signal for Single-ended G1: Common ground 1 G2: Common ground 2

- Note.
- 1 The header connectors are decided by board distance (stacking height). Connector combination is shown in Table 1.
  - 2 Fixed side (Black side) of interposer should be mated with header mounted on board  $\alpha$ . Mating side (Gray side) should be mated with header mounted on board  $\beta$ .
  - 3 Spacers are required to support the PWB's and protect the SMT solder joints. Recommended spacer height is shown in Table 1.
  - 4 Pin configuration is shown in Table 2. This product consists of 36 Differential pairs ,8 Single-ended lines and 40 ground lines.
  - 5 Lot No. shall be marked on the indicated position.
  - 6 50pcs of this product are packed in soft tray. See Fig.3 for details.

3	Copper Alloy	Ni1.5 $\mu$ m+Au0.76 $\mu$ m	6	PS	(Tray)		
2	LCP(Black)	UL94V-0	5	Copper Alloy	Ni1 $\mu$ m		
1	LCP(Gray)	UL94V-0	4	Copper Alloy	Ni1 $\mu$ m <span style="border: 1px solid black; padding: 1px;">1</span>		
NO.	MATERIAL	FINISH . REMARKS	NO.	MATERIAL	FINISH . REMARKS		
UNITS	$\varnothing$	SCALE	COUNT	DESCRIPTION OF REVISIONS	DESIGNED	CHECKED	DATE
mm		2 : 1	3	DIS-F-00002513	AS. MATSUZAWA	MK. EZAKI	17. 07. 14
APPROVED : TM. MATSUO		17. 07. 04	DRAWING NO.		EDC-361675-03-00		
CHECKED : MK. EZAKI		17. 07. 04	PART NO.		FX10-120IP-36Q-8H(03)		
DESIGNED : AS. MATSUZAWA		17. 07. 04	CODE NO.		CL608-0015-8-03		
DRAWN : XINGYU CHENG		17. 07. 04			<span style="border: 1px solid black; padding: 1px;">1</span> / <span style="border: 1px solid black; padding: 1px;">2</span>		

May.1.2023 Copyright 2023 HIROSE ELECTRIC CO., LTD. All Rights Reserved.  
 In case of consideration for using Automotive equipment / device which demand high reliability, kindly contact our sales window correspondents.

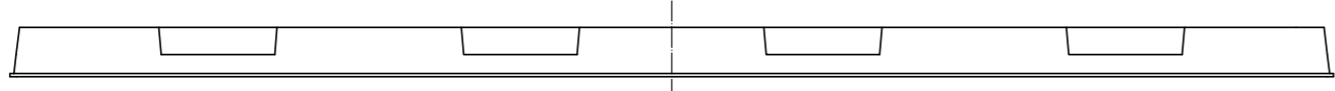
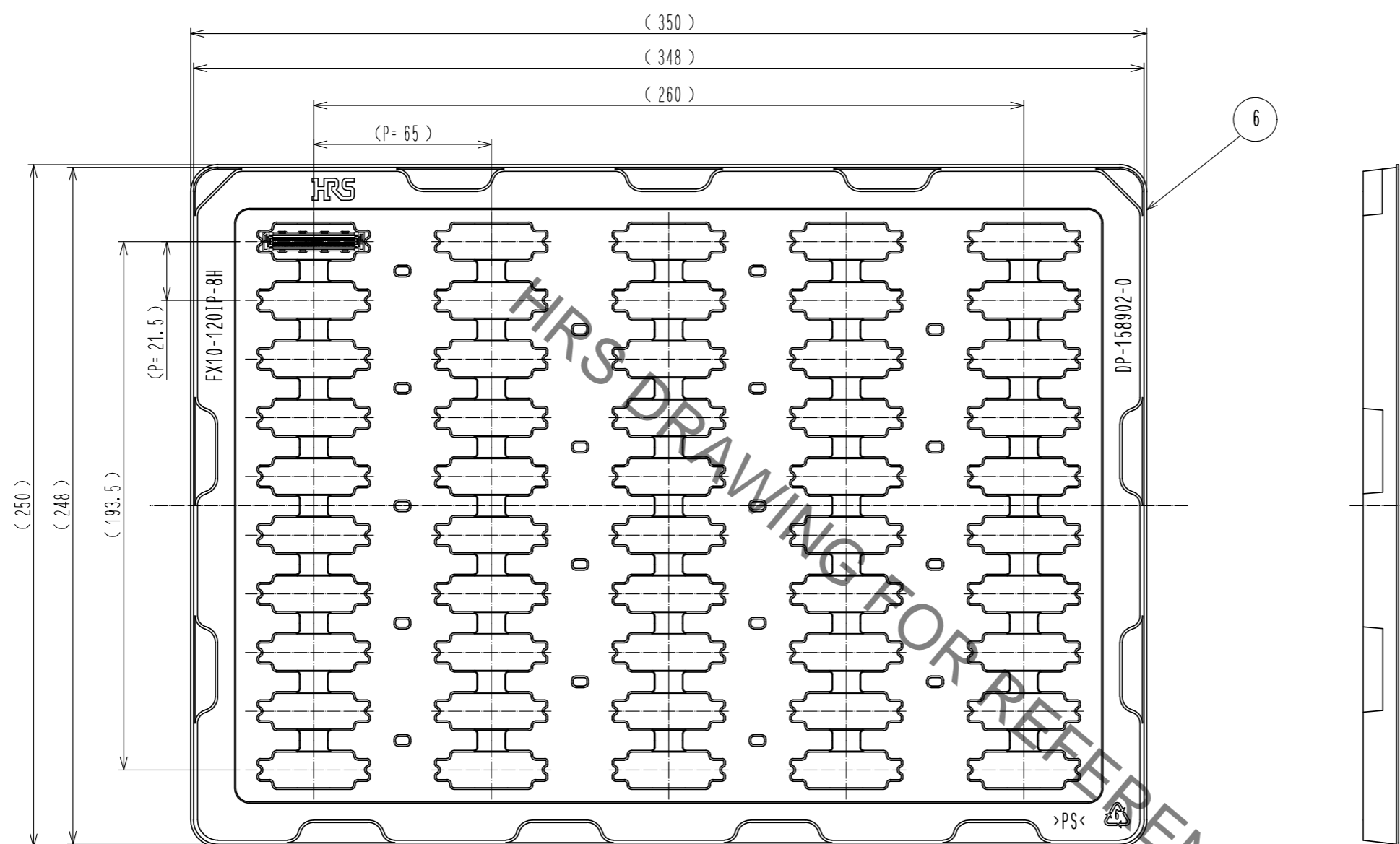

Fig.3 Drawing for packing (1:2) ◁ 6

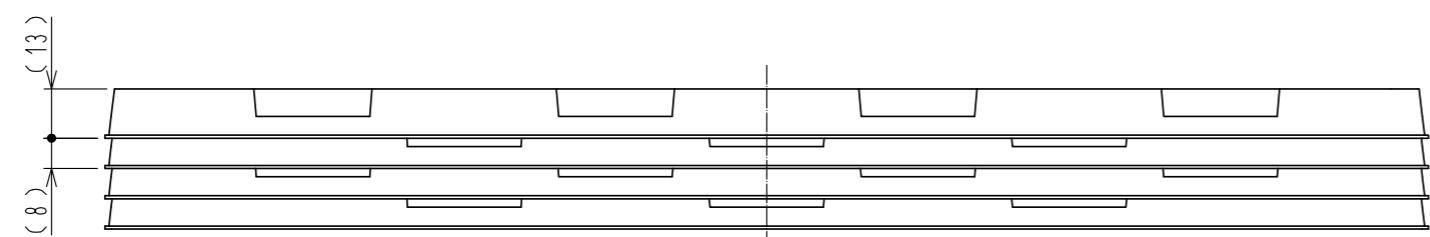

Fig.4 Stacked tray drawing (1:2)

<b>HRS</b>	DRAWING NO.	EDC-361675-03-00
	PART NO.	FX10-120IP-36Q-8H(C03)
	CODE NO.	CL608-0015-8-03

2/2