

May.1.2023 Copyright 2023 HIROSE ELECTRIC CO., LTD. All Rights Reserved.
In case of consideration for using Automotive equipment / device which demand high reliability, kindly contact our sales window correspondents.

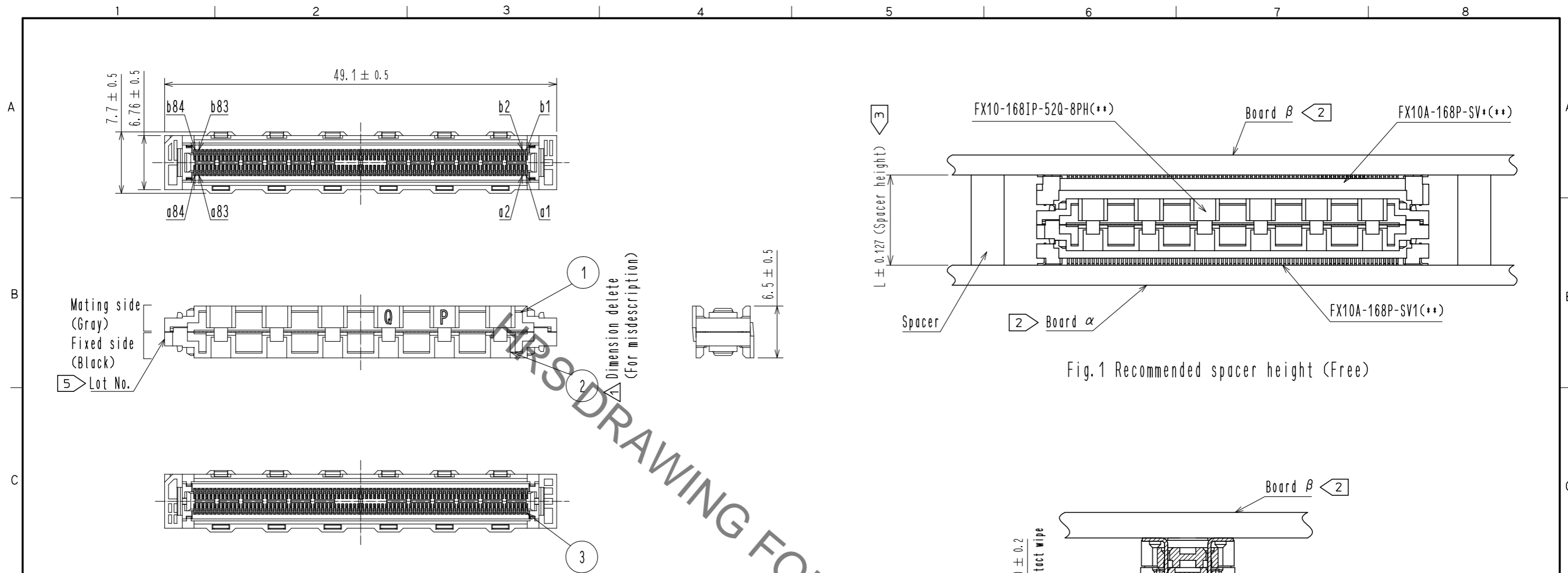

Fig.1 Recommended spacer height (Free)

Table.1 Stacking height and connector combinations 1

Board distance (Stacking height)	Header connector of Board α	Interposer	Header connector of Board β	Recommended spacer height(L) 3
11mm	FX10A-168P-SV1(**)	FX10A-168IP-52Q-8PH(**)	FX10A-168P-SV2(**)	11±0.127mm
12mm	FX10A-168P-SV1(**)		FX10A-168P-SV3(**)	12±0.127mm
13mm	FX10A-168P-SV1(**)		FX10A-168P-SV4(**)	13±0.127mm

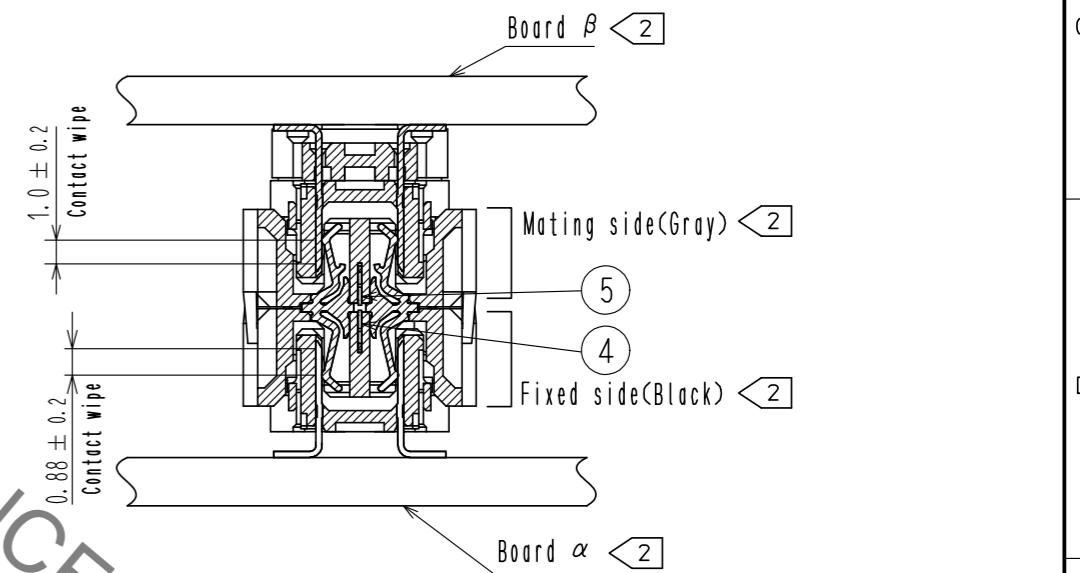

Fig.2 Mating cross section (Free)

- Note.
- 1 The header connectors are decided by board distance (stacking height). Connector combination is shown in Table 1.
 - 2 Fixed side (Black side) of interposer should be mated with header mounted on board α .
Mating side (Gray side) should be mated with header mounted on board β .
 - 3 Spacers are required to support the PWB's and protect the SMT solder joints.
Recommended spacer height is shown in Table 1.
 - 4 Pin configuration is shown in Table 2.
This product consists of 52 Differential pairs, 8 Single-ended lines and 56 ground lines.
 - 5 Lot No. shall be marked on the indicated position.
 - 6 50pcs of this product are packed in soft tray. See Fig.3 for details.

3	Copper Alloy	Ni1.5 μ m+Au0.76 μ m	6	PS	(Tray)		
2	LCP(Black)	UL94V-0	5	Copper Alloy	Ni1 μ m		
1	LCP(Gray)	UL94V-0	4	Copper Alloy	Ni1 μ m		
NO.	MATERIAL	FINISH . REMARKS	NO.	MATERIAL	FINISH . REMARKS		
UNITS mm		SCALE 2 : 1	COUNT 6	DESCRIPTION OF REVISIONS DIS-F-00002626	DESIGNED AS. MATSUZAWA	CHECKED MK. EZAKI	DATE 17. 09. 04
APPROVED : MK. EZAKI			16. 11. 05	DRAWING NO. EDC-354341-03-00			
CHECKED : MK. EZAKI			16. 11. 05	PART NO. FX10-168IP-52Q-8PH(C03)			
DESIGNED : MK. NAGATA			16. 11. 05	CODE NO. CL608-0005-4-03			
DRAWN : MK. NAGATA			16. 11. 05	1/2			

May.1.2023 Copyright 2023 HIROSE ELECTRIC CO., LTD. All Rights Reserved.
 In case of consideration for using Automotive equipment / device which demand high reliability, kindly contact our sales window correspondents.

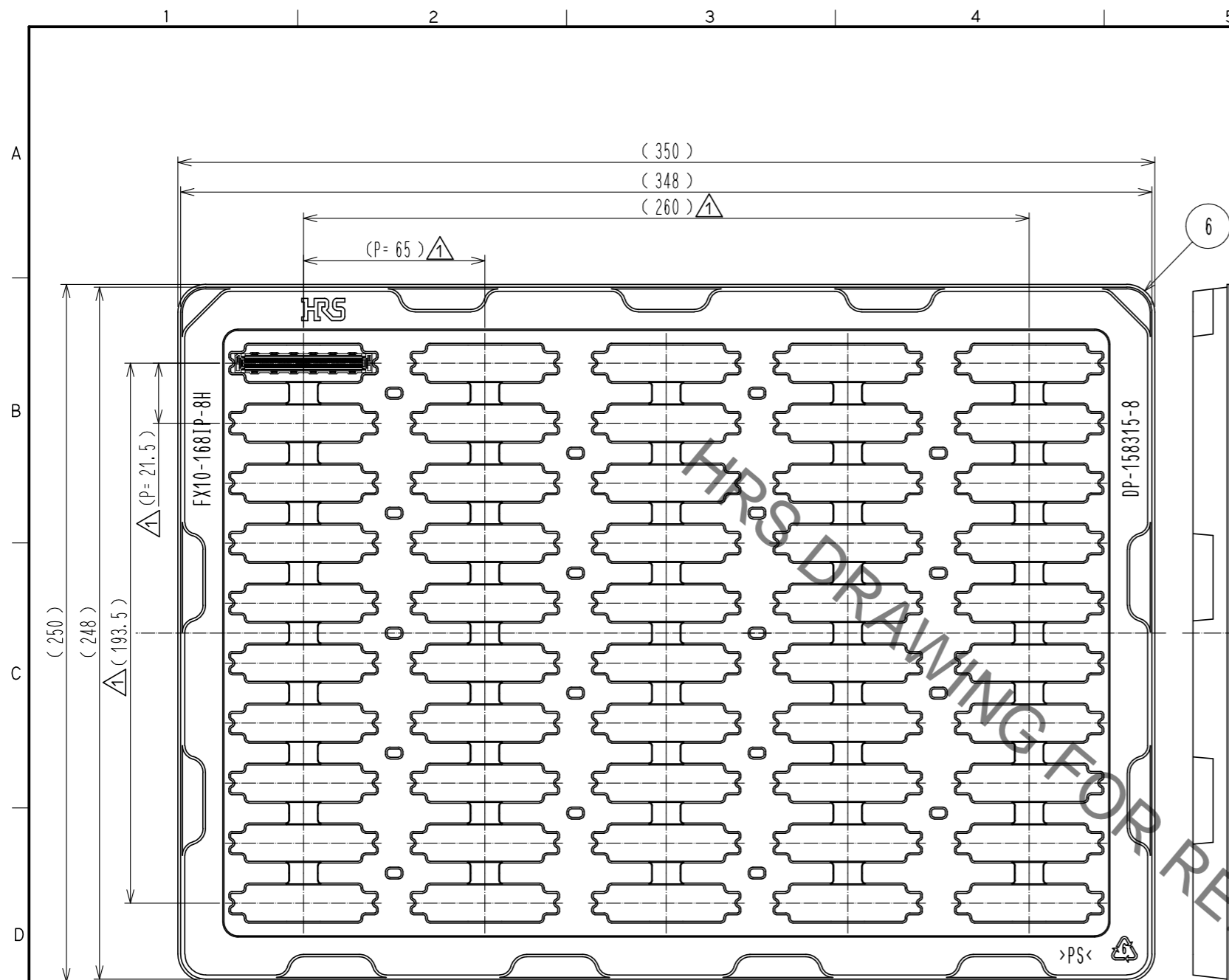

Fig.3 Drawing for packing (1:2) 6

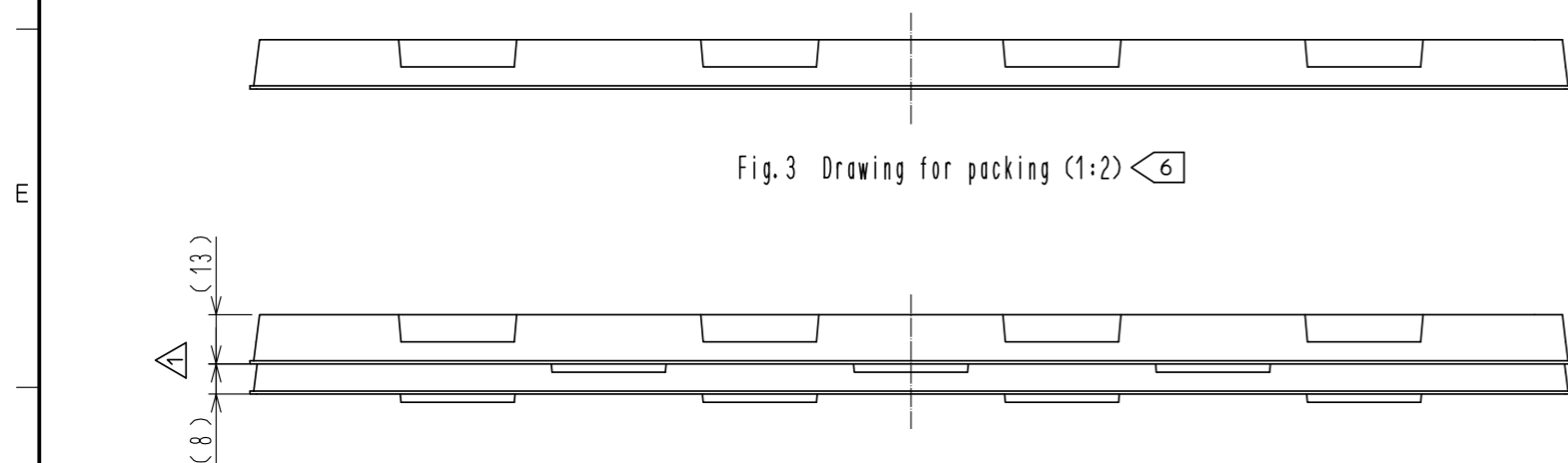

Fig.4 Stacked tray drawing (1:2)

Table.2 Pin configuration of Interposer 4

Row A Pin No.	a1	a2	a3	a4	a5	a6	a7	a8	a9	a10	a11	a12
Pin configuration	G1	S	S	G1	S	S	G1	S	S	G1	S	S
Row A Pin No.	a13	a14	a15	a16	a17	a18	a19	a20	a21	a22	a23	a24
Pin configuration	G1	S	S	G1	S	S	G1	S	S	G1	S	S
Row A Pin No.	a25	a26	a27	a28	a29	a30	a31	a32	a33	a34	a35	a36
Pin configuration	G1	S	S	G1	S	S	G1	S	S	G1	S	S
Row A Pin No.	a37	a38	a39	a40	a41	a42	a43	a44	a45	a46	a47	a48
Pin configuration	G1	S	S	G1	SE	SE	SE	SE	G2	S	S	G2
Row A Pin No.	a49	a50	a51	a52	a53	a54	a55	a56	a57	a58	a59	a60
Pin configuration	S	S	G2	S	S	G2	S	S	G2	S	S	G2
Row A Pin No.	a61	a62	a63	a64	a65	a66	a67	a68	a69	a70	a71	a72
Pin configuration	S	S	G2	S	S	G2	S	S	G2	S	S	G2
Row A Pin No.	a73	a74	a75	a76	a77	a78	a79	a80	a81	a82	a83	a84
Pin configuration	S	S	G2	S	S	G2	S	S	G2	S	S	G2

Row B Pin No.	b1	b2	b3	b4	b5	b6	b7	b8	b9	b10	b11	b12
Pin configuration	G1	S	S	G1	S	S	G1	S	S	G1	S	S
Row B Pin No.	b13	b14	b15	b16	b17	b18	b19	b20	b21	b22	b23	b24
Pin configuration	G1	S	S	G1	S	S	G1	S	S	G1	S	S
Row B Pin No.	b25	b26	b27	b28	b29	b30	b31	b32	b33	b34	b35	b36
Pin configuration	G1	S	S	G1	S	S	G1	S	S	G1	S	S
Row B Pin No.	b37	b38	b39	b40	b41	b42	b43	b44	b45	b46	b47	b48
Pin configuration	G1	S	S	G1	SE	SE	SE	SE	G2	S	S	G2
Row B Pin No.	b49	b50	b51	b52	b53	b54	b55	b56	b57	b58	b59	b60
Pin configuration	S	S	G2	S	S	G2	S	S	G2	S	S	G2
Row B Pin No.	b61	b62	b63	b64	b65	b66	b67	b68	b69	b70	b71	b72
Pin configuration	S	S	G2	S	S	G2	S	S	G2	S	S	G2
Row B Pin No.	b73	b74	b75	b76	b77	b78	b79	b80	b81	b82	b83	b84
Pin configuration	S	S	G2	S	S	G2	S	S	G2	S	S	G2

S: Signal for Differential SE: Signal for Single-ended G1: Common ground 1 G2: Common ground 2

HRS	DRAWING NO.	EDC-354341-03-00
	PART NO.	FX10-168IP-52Q-8PH(03)
	CODE NO.	CL608-0005-4-03 2/2