

Apr.1.2023 Copyright 2023 HIROSE ELECTRIC CO., LTD. All Rights Reserved.
In case of consideration for using Automotive equipment / device which demand high reliability, kindly contact our sales window correspondents.

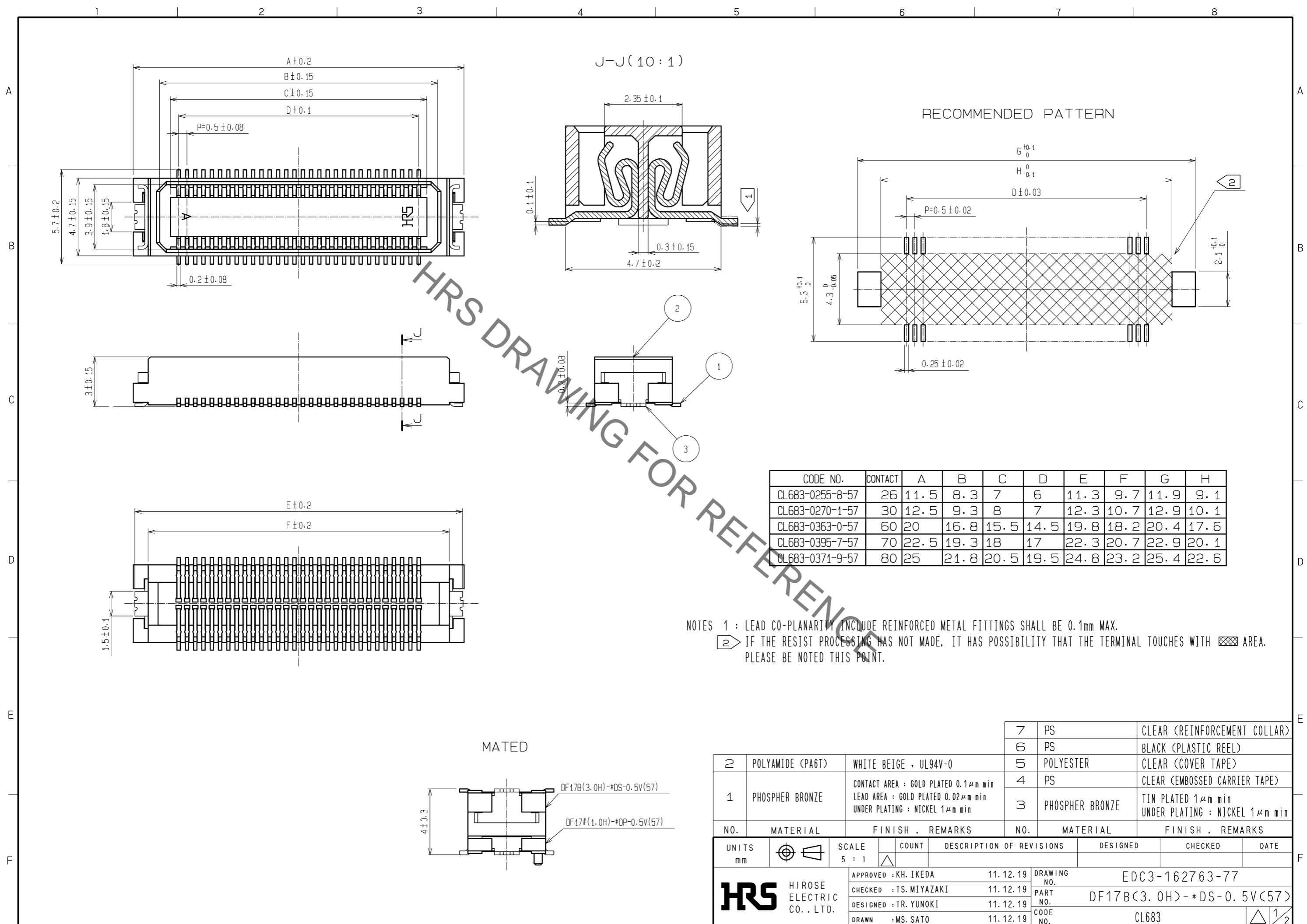

CODE NO.	CONTACT	A	B	C	D	E	F	G	H
CL683-0255-8-57	26	11.5	8.3	7	6	11.3	9.7	11.9	9.1
CL683-0270-1-57	30	12.5	9.3	8	7	12.3	10.7	12.9	10.1
CL683-0363-0-57	60	20	16.8	15.5	14.5	19.8	18.2	20.4	17.6
CL683-0395-7-57	70	22.5	19.3	18	17	22.3	20.7	22.9	20.1
CL683-0371-9-57	80	25	21.8	20.5	19.5	24.8	23.2	25.4	22.6

NOTES 1 : LEAD CO-PLANARITY INCLUDE REINFORCED METAL FITTINGS SHALL BE 0.1mm MAX.
 2 IF THE RESIST PROCESSING HAS NOT MADE, IT HAS POSSIBILITY THAT THE TERMINAL TOUCHES WITH AREA. PLEASE BE NOTED THIS POINT.

NO.	MATERIAL	FINISH . REMARKS	NO.	MATERIAL	FINISH . REMARKS
2	POLYAMIDE (PA6T)	WHITE BEIGE , UL94V-0	7	PS	CLEAR (REINFORCEMENT COLLAR)
1	PHOSPHER BRONZE	CONTACT AREA : GOLD PLATED 0.1μm min LEAD AREA : GOLD PLATED 0.02μm min UNDER PLATING : NICKEL 1μm min	6	PS	BLACK (PLASTIC REEL)
			5	POLYESTER	CLEAR (COVER TAPE)
			4	PS	CLEAR (EMBOSSED CARRIER TAPE)
			3	PHOSPHER BRONZE	TIN PLATED 1μm min UNDER PLATING : NICKEL 1μm min

UNITS	SCALE	COUNT	DESCRIPTION OF REVISIONS	DESIGNED	CHECKED	DATE
mm	5 : 1	△				
APPROVED : KH. IKEDA			11.12.19	DRAWING NO. EDC3-162763-77		
CHECKED : TS. MIYAZAKI			11.12.19	PART NO. DF17B(3.0H)-*DS-0.5V(57)		
DESIGNED : TR. YUNOKI			11.12.19	CODE NO. CL683		
DRAWN : MS. SATO			11.12.19	1/2		

MATED

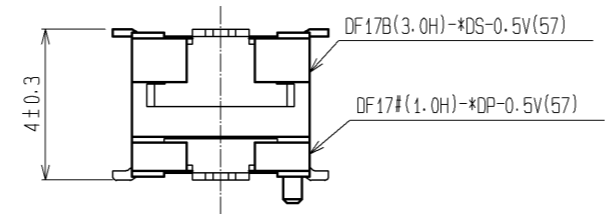

Apr.1.2023 Copyright 2023 HIROSE ELECTRIC CO., LTD. All Rights Reserved.
 In case of consideration for using Automotive equipment / device which demand high reliability, kindly contact our sales window correspondents.

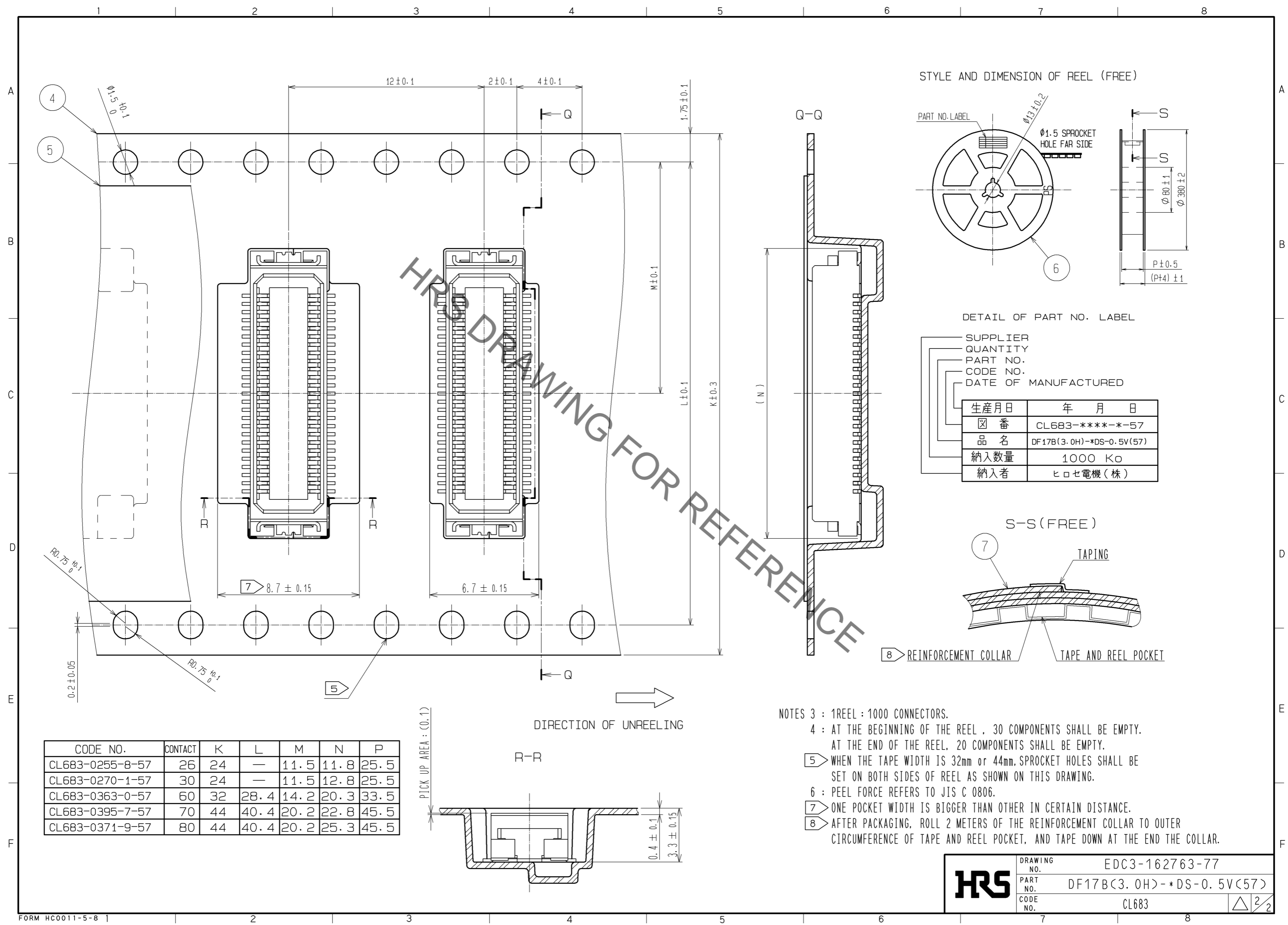

STYLE AND DIMENSION OF REEL (FREE)

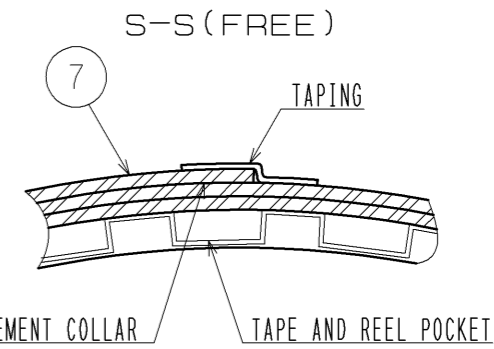
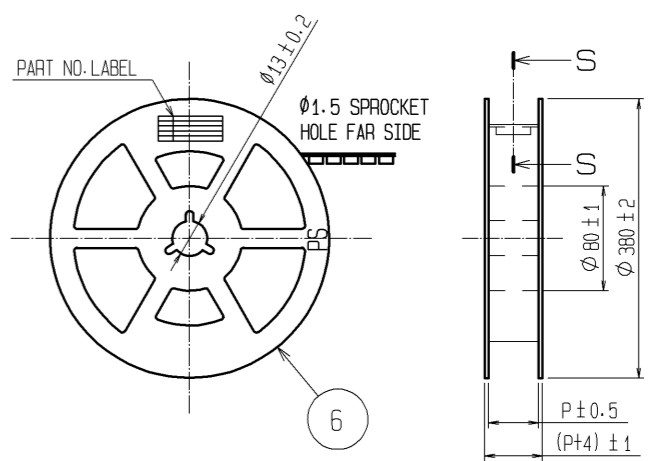

DIRECTION OF UNREELING

- NOTES 3 : 1REEL : 1000 CONNECTORS.
 4 : AT THE BEGINNING OF THE REEL , 30 COMPONENTS SHALL BE EMPTY.
 AT THE END OF THE REEL, 20 COMPONENTS SHALL BE EMPTY.
 5 WHEN THE TAPE WIDTH IS 32mm or 44mm, SPROCKET HOLES SHALL BE SET ON BOTH SIDES OF REEL AS SHOWN ON THIS DRAWING.
 6 : PEEL FORCE REFERS TO JIS C 0806.
 7 ONE POCKET WIDTH IS BIGGER THAN OTHER IN CERTAIN DISTANCE.
 8 AFTER PACKAGING, ROLL 2 METERS OF THE REINFORCEMENT COLLAR TO OUTER CIRCUMFERENCE OF TAPE AND REEL POCKET, AND TAPE DOWN AT THE END THE COLLAR.

CODE NO.	CONTACT	K	L	M	N	P
CL683-0255-8-57	26	24	—	11.5	11.8	25.5
CL683-0270-1-57	30	24	—	11.5	12.8	25.5
CL683-0363-0-57	60	32	28.4	14.2	20.3	33.5
CL683-0395-7-57	70	44	40.4	20.2	22.8	45.5
CL683-0371-9-57	80	44	40.4	20.2	25.3	45.5

HRS DRAWING NO. EDC3-162763-77
 PART NO. DF17B(3.0H)-*DS-0.5V(57)
 CODE NO. CL683