

May.1.2023 Copyright 2023 HIROSE ELECTRIC CO., LTD. All Rights Reserved.
In case of consideration for using Automotive equipment / device which demand high reliability, kindly contact our sales window correspondents.

RECOMMENDED LAND PATTERN DIMENSION OF PCB(2:1)
 (PCB THICKNESS:t=1.6mm METAL MASK THICKNESS:t=0.12mm)

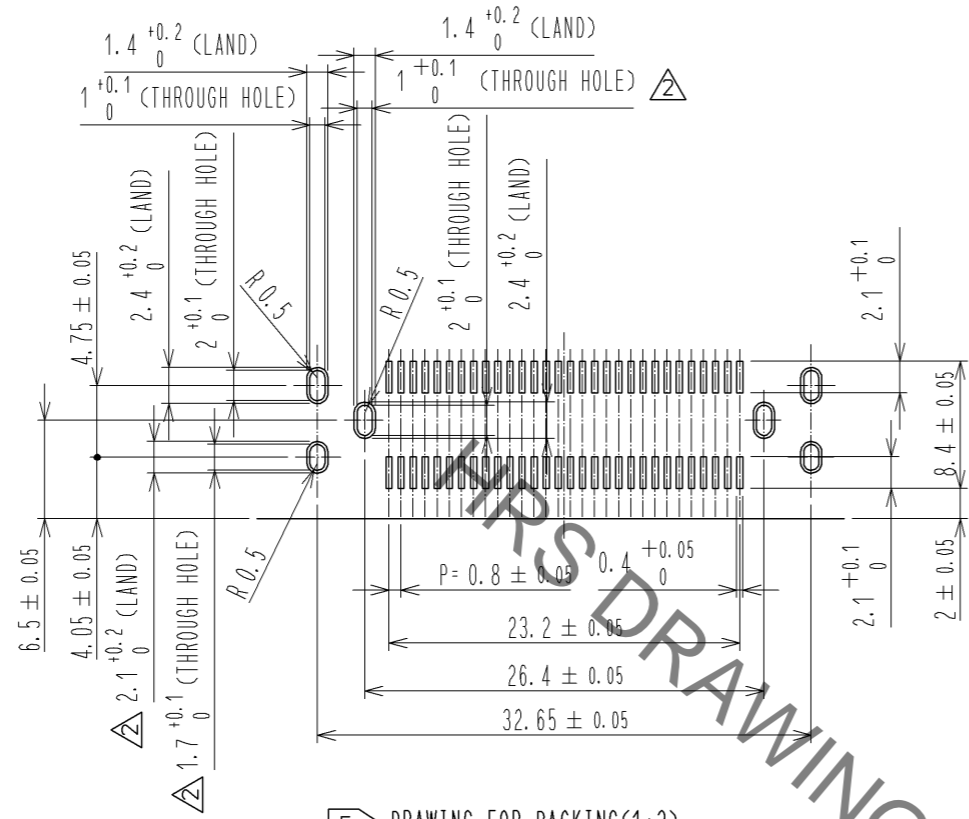

8 CONFIGURATION OF MF CONTACT A

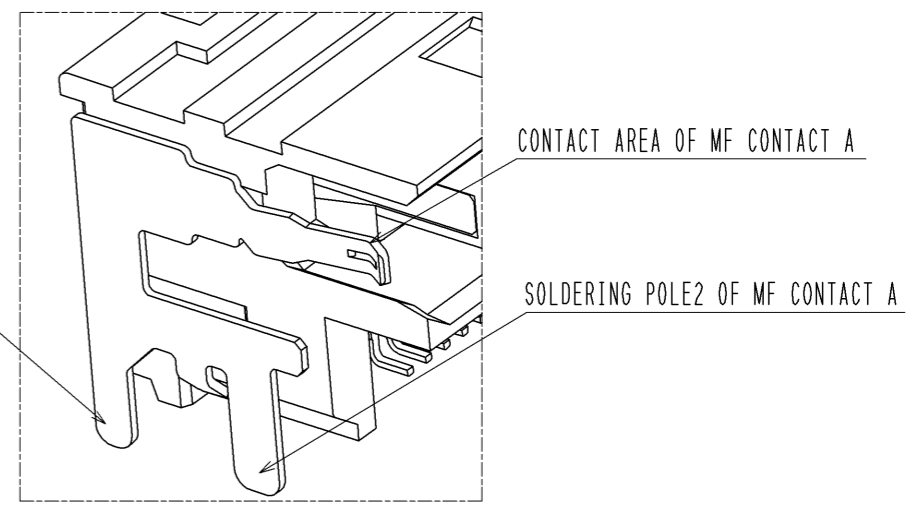

NOTE 8 SOLDERING LEAD OF MF CONTACT A SPLITS INTO TWO POLES. BE SURE TO CONNECT TO THE SAME CIRCUIT.

5 DRAWING FOR PACKING(1:2)

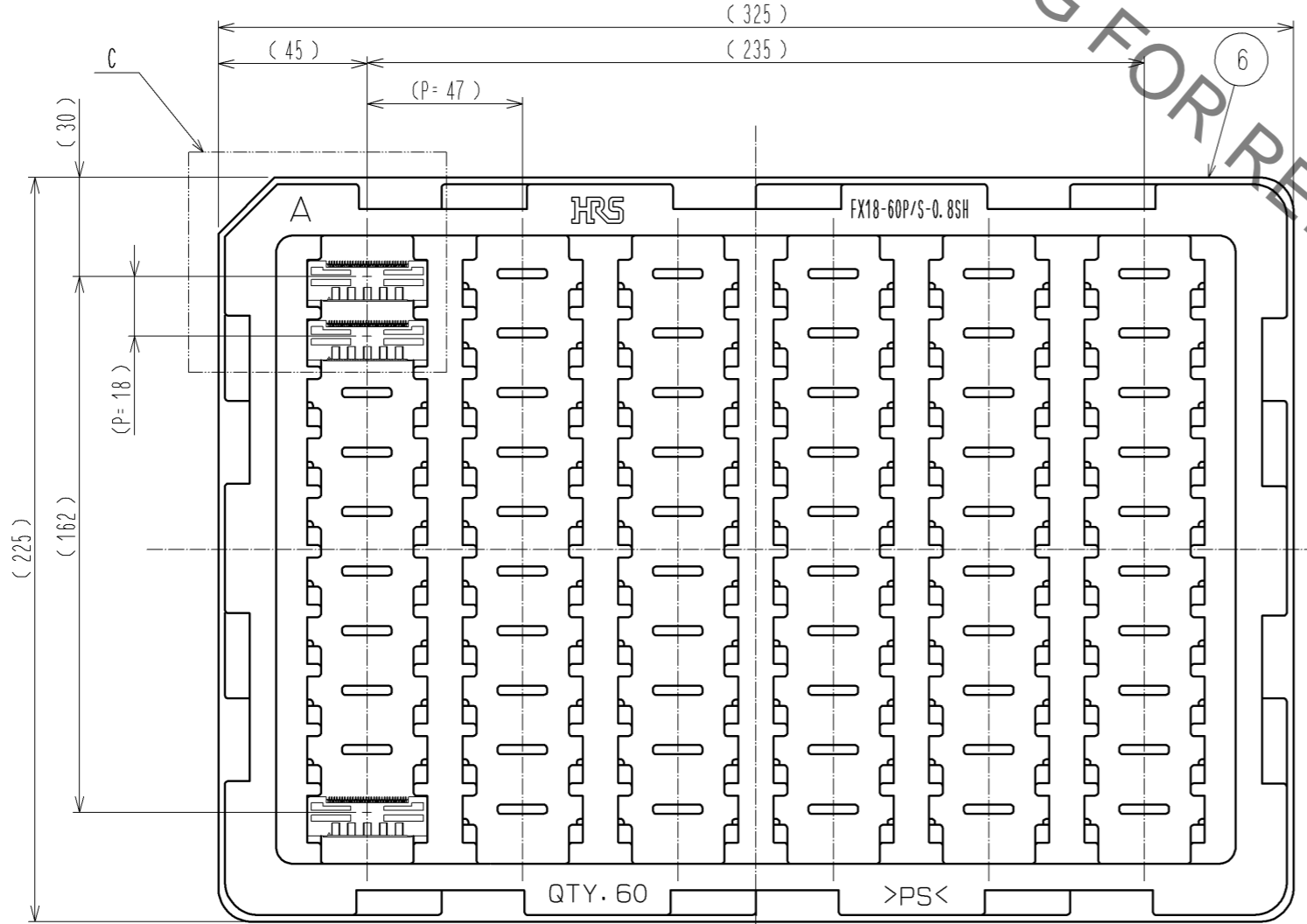

(18)

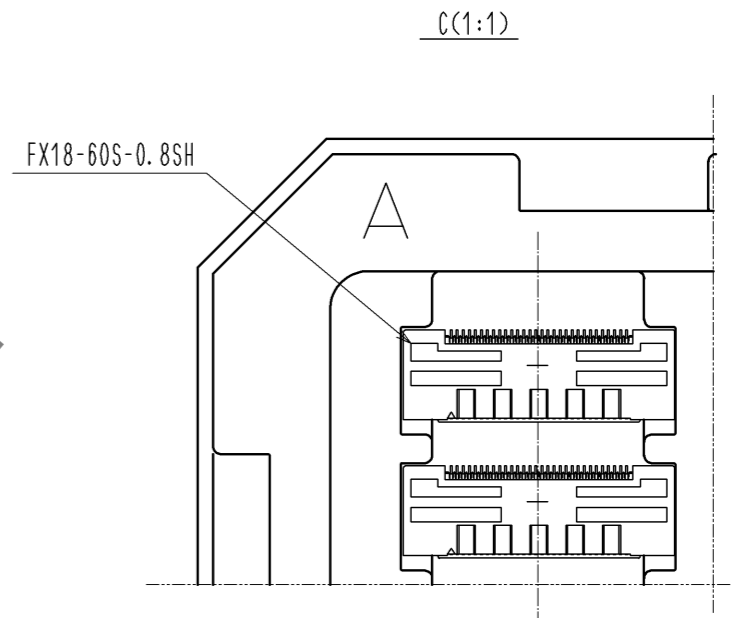

QTY. 60 >PS<

HRS	DRAWING NO.	EDC3-159082-00	2/2
	PART NO.	FX18-60S-0.8SH	
	CODE NO.	CL579-0010-3-00	