

29F0429-0T0-10

PHYSICAL DIMENSIONS:

A	10.88	[.428]	+	0.15	[.006]
B	5.49	[.216]	+	0.08	[.003]
C	10.44	[.411]	+	0.25	[.010]
C1	11.43	[.450]	+	MAX	
D	2.54	[.100]	+	0.13	[.005]
E	2.54	[.100]	+	0.13	[.005]

T1	3.17	[.125]	+	TYP.
T2	0.64	[.025]	+	REF.

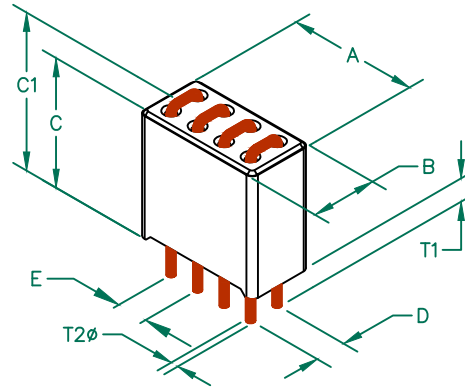

ELECTRICAL CHARACTERISTICS:			
Z @ 100MHz (Ω)	DCR (Ω)	Rated Current	
Nominal	285		
Minimum	214		
Maximum	356	0.01	8,000 mA

NOTES: UNLESS OTHERWISE SPECIFIED

1. BULK PACKED 1260 per CASE.
2. COMPONENTS SHOULD BE ADEQUATELY PREHEATED BEFORE SOLDERING.
3. TERMINATION FINISH IS 100% TIN.
6. OPERATION TEMPERATURE (INCLUDING SELF-HEATING):
-40 ~ +125°C.

|Z| , R, AND X vs. FREQUENCY

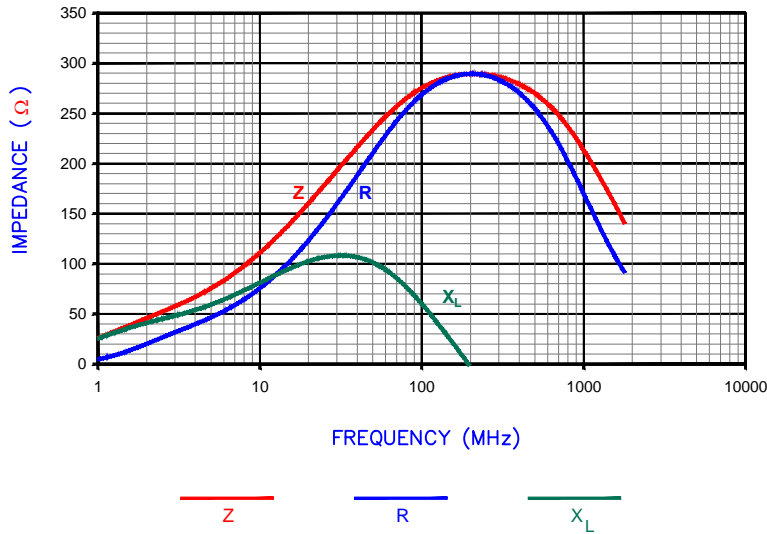

HOLE PATTERN FOR THRU-HOLE INSERTION

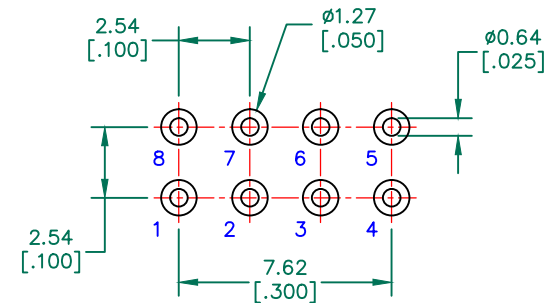

RoHS

DIMENSIONS ARE IN mm [INCHES].				This print is the property of Laird Tech. and is loaned in confidence subject to return upon request and with the understanding that no copies shall be made without the written consent of Laird Tech. All rights to design or invention are reserved.			
E	ADD NOTE 6	08/30/12	QIU	PROJECT/PART NUMBER: 29F0429-0T0-10	REV	PART TYPE:	DRAWN BY:
D	UPDATE COMPANY LOGO	10/21/08	JRK		E	ASSEMBLY	TMB
C	ADD ROHS SYMBOL UPDATE LOGO	05/02/07	JRK	DATE:	SCALE:	SHEET:	
B	CHG T1 FROM .142, ADD NUMBERING TO HOLE PATTERN, ADD NOTE 3	06/23/04	JRK	02/20/04	NTS		
A	ORIGINAL DRAFT	02/20/04	TMB	CAD #	TOOL #		
REV	DESCRIPTION	DATE	INT	29F0429-0T0-10-E-1	H0429		1 of 2



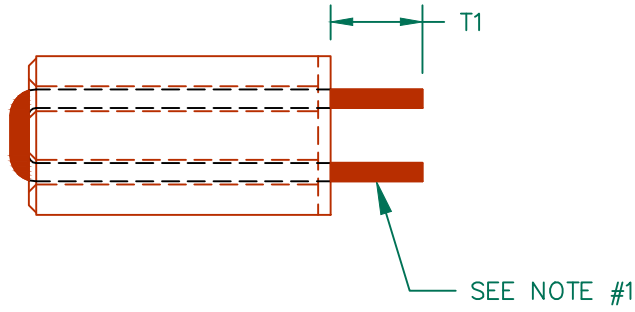
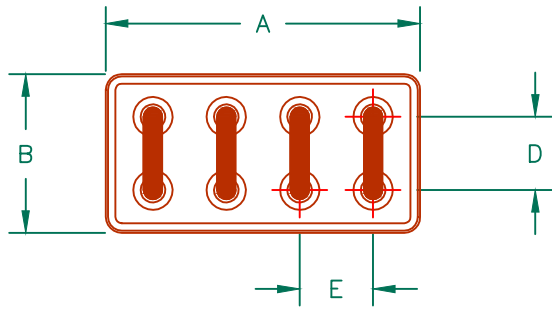

SCALE DRAWING 1:1

29F0429-0T0-10

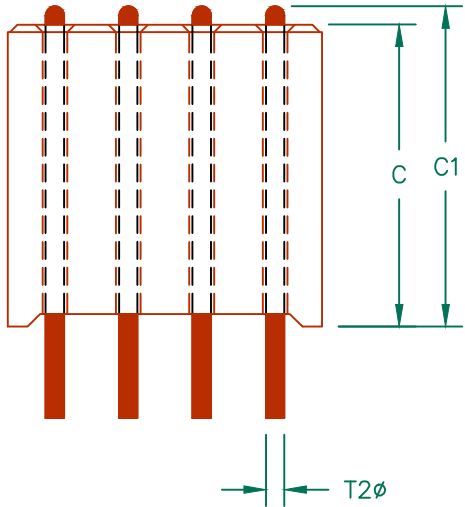

ELECTRICAL TESTING

TEST:	Z	Z
# TURNS	1	1
AWG	22	22
FREQUENCY	25 MHz	100 MHz
NOMINAL	205 Ω	285 Ω
MINIMUM	- Ω	214 Ω
WEIGHT/1000	2.72 kgs.	6.00 lbs.



- NOTES: UNLESS OTHERWISE SPECIFIED
1. REF. STEWARD WIRE SPEC. W0303-*
 2. IMPEDANCE VALUES ARE GROSS, MEASURED USING W0303-* WIRE.
 3. REF. STEWARD CORE P/N 29H0429-000.
 4. TERMINATION FINISH IS 100% TIN.

DIMENSIONS:

A	10.88 [.428]	+	0.15 [.006]
B	5.49 [.216]	+	0.08 [.003]
C	10.44 [.411]	+	0.25 [.010]
C1	11.43 [.450]	+	MAX.
D	2.54 [.100]	+	0.13 [.005]
E	2.54 [.100]	+	0.13 [.005]

WIRE DIMENSIONS:

T1	3.17 [.125]	+	TYP.
T2	0.64 [.025]	+	REF.

DIMENSIONS ARE IN mm [INCHES].				This print is the property of Laird Tech. and is loaned in confidence subject to return upon request and with the understanding that no copies shall be made without the written consent of Laird Tech. All rights to design or invention are reserved.			Laird		
E	ADD NOTE 6	08/30/12	QIU	PROJECT/PART NUMBER: 29F0429-0T0-10			REV	PART TYPE:	DRAWN BY:
D	UPDATE COMPANY LOGO	10/21/08	JRK				E	ASSEMBLY	TMB
C	ADD ROHS SYMBOL UPDATE LOGO	05/02/07	JRK	DATE:	02/20/04	SCALE:	N.T.S.	SHEET:	
B	CHG T1 FROM .142, ADD NUMBERING TO HOLE PATTERN, ADD NOTE 3	06/23/04	JRK	CAD #	29F0429-0T0-10-E-2	TOOL #	H0429	2 of 2	
A	ORIGINAL DRAFT	02/20/04	TMB						
REV	DESCRIPTION	DATE	INT						