



## **FA1 Series Air Filtration System**

### **Operations Manual**

#### **READ AND SAVE THESE INSTRUCTIONS**

**WARNING:**

 Disconnect from power supply before performing maintenance procedures such as cabinet cleaning, changing filters or servicing of electric motor or other electric components

**WARNING:**

 To reduce the risk of fire or electric shock, do not use this fan with any solid-state speed control device.

**WARNING:**

 For general ventilating use only. Do not use to exhaust hazardous or explosive materials or vapors.

**WARNING:**

 Use only a 10-Amp fuse.

**CAUTION:**

 Do not operate without having all filters in place.

Do not operate any fan with a damaged cord or plug. Discard fan or return to an authorized service facility for examination and/or repair.

Do not run cord under carpeting. Do not cover cord with throw rugs, runners or similar coverings. Arrange cord away from traffic area and where it will not be tripped over.

# GETTING STARTED

## Initial set-up

1. Open all cartons and locate inlet, hose, hose clamps and wheels. Refer to Table 1 for the applicable part numbers for your model.
2. Remove ALL filters and packing materials from cartons and the unit cabinet.
3. Place the unit on its side and install wheels in the bottom plate.
4. Attach the inlet to the top of the lid with the six screws provided.
5. Remove plastic wrap from gas/odor filter.
6. Carefully remove perforated cardboard from top and bottom of FA101D filter to expose “Green” media.
7. Place FA101D gas/odor filter into bottom of cabinet (NOTE: Pay attention to direction of airflow arrow).
8. Place FA100 HEPA filter on top of gas/odor filter (NOTE: Pay attention to direction of airflow arrow).
9. Place the FA102B pre-filter on top of the HEPA filter.
10. Close and latch the lid.
11. Attach power cord to the power receptacle located on the lower rear of the cabinet.

## Locating the air cleaner

Placing the FA1 unit as close as possible to the pollution source reduces the amount of ducting needed, reduces back-pressure, lowers power consumption, and improves overall performance. Placement should minimize hose length and the number of bends. Use capture hoods with high efficiency entry whenever possible. The unit exhausts through the bottom panel make sure to allow for adequate ventilation.

## Inlet hose attachment

The FA1 unit ships standard with a 1 x 2”, 2 x 2” or 1 x 3” inlet. Attach flex hose over the metal air inlet tube and tighten securely with the stainless-steel clamp. Connect the hose to a Fumex suction hood or place as close as possible to the pollution source.

## Electric power

FA1 is manufactured with a universal blower/motor assembly (90-250/1/50-60) and must only use a 10-Amp fuse. Default power cord/plug is US (120V). Contact Fumex for additional information or options.

***Confirm that correct power supply is available.***

# CONTROLS

## On/Off Switch

Simple one touch controls – The green light above the POWER button will illuminate confirming power to the unit.

## Blower/Fan

The FA1 utilizes a variable speed blower with three speed settings. Press the up and down arrow buttons to increase/decrease blower speed. A green light next to the specific speed (Low, Med, or High) will indicate speed setting. In the case of a blower failure, all 3 blower speed lights will flash. To reset the blower's internal thermal protection, disconnect the unit momentarily from its power source and reconnect. If the lights continue to flash contact Fumex LLC. for replacement information.

## Filter monitoring

The FA1 utilizes a pressure differential switch to monitor the status of the particulate filters. The system monitors across all filters simultaneously and the Red "FILTER" light will illuminate when one or more filters need to be replaced. The recommended procedure is to first replace the Pre-Filter and then press the "FILTER RESET" button. If the light remains illuminated or turns off and comes back on then replace the HEPA filter and press the "FILTER RESET" button.

The FA1 contains a VOC sensor to detect odors/gases in the exhaust stream. When the gas/odor filter becomes saturated, and breakthrough of the VOC occurs the "GAS" warning light will illuminate.

# GENERAL FILTER CARE

Fumex's FA1 air purifier features a multi-stage filtration system designed to remove a wide range of pollutants from the process plume in an extremely efficient, cost-effective manner. The system utilizes a pressure differential switch to indicate blocked / clogged filters. Once the warning lights illuminate, filters should be checked, and clogged filters replaced.

## **STANDARD FILTERS:**

### Part # FA102B Pre-filter Assembly

The pre-filter assembly is the first stage in the filtration process. The assembly is composed of high capacity merv 11 rated filter media protected by polyester pre-filter. Unique design minimizes operator/maintenance personnel exposure to contaminants.

#### *Replacement:*

The unique design of the pre-filter allows the filter to be changed as a complete unit or in heavy dust applications the polyester pre-filter can be removed independently. Contact Fumex LLC. regarding any questions/assistance.

### **Part # FA100 HEPA Filter**

The HEPA filter is 99.97% efficient in removing particles as small as 0.3 $\mu$  from an airstream. Particles of this size are respirable and can cause significant respiratory problems.

#### ***Replacement:***

A HEPA's service life is determined by the volume of sub-micron particles remaining in the airstream after passing through the pre-filters. When properly protected, and depending on loading, HEPA filters often provide months of service. Average service life is 2-4 months.

### **Part # FA101D Gas/Odor Filter**

Most process plumes contain several gases, some odorous – some not, some toxic at elevated concentrations – some completely harmless regardless of concentration. To ensure employee safety the type and concentration of pollutants must be determined. Please contact Fumex Engineering for filter selection assistance. These filters utilize a blended activated carbon and activated alumina impregnated with KMnO<sub>4</sub> filter to capture and treat gases/odors. This combination of materials provides protection across a broad range of gases commonly found in industrial manufacturing processes.

## **GENERAL MAINTENANCE**

- 1) The blower motor is a sealed unit, 24,000 hr. MTBF rated. It is permanently lubricated and does not require oiling – keep it free of dust accumulations to prevent overheating.
- 2) Remove any loose accumulations of dust/debris from the air filter chamber periodically.

“This product employs overload protection (fuse). A blown fuse indicates an overload or short-circuit situation. If the fuse blows, unplug the product from the outlet. Replace the fuse as per the user servicing instructions (only 10-Amp fuse) and check the product. If the replacement fuse blows, a short circuit may be present and the product should be discarded or returned to an authorized service facility for examination and/or repair”.

## **Remote Interface and Connectivity Function**

The FA1 can be supplied with an optional interface package providing remote start/stop and filter monitoring capabilities (Part # FA228). Please see instructions below for Relay Activation/De-Activation procedures and refer to the drawing in Figure 1 for remote connections.

### **WARNING**

**“To Prevent the Risk of Electrical Shock, Connect Remote Interface Cable to 24v, Class 2 Power Supply Only”**



### **WARNING**

**“Disconnect from All Power Supplies Before Servicing”**



<b>R e p l a c e m e n t P a r t s</b>			
<b>Part #</b>	<b>Item</b>	<b>Part #</b>	<b>Item</b>
	<b>Cabinetry</b>		<b>Electrical</b>
FA108	Wheels, standard	FAAU500	Universal blower motor / assembly – 90-250/1/50-60
FA109	Vibration Isolators	FA004	Control board assembly
FA117	Cabinet latch	FA113	Fuseholder
FA118	Cabinet hinge	FA114	Fuse, 10 amp
FA106A	Flanged air inlet 3"Ø	FA115	Cordset (120vac)
FA106B	Flanged air inlet 2 x 2"Ø	FA115B	Cordset (240vac)
FA106C	Flanged air inlet 1 x 2"		
	<b>Filters</b>		<b>Gas / Odor Filters</b>
FA102B	Pre-Filter	FA101D	Blended carbon media – 2"
FA103	Polyester pre-filter		
FA100	HEPA Filter – 6"		

Table 1

## **Warranty and Liability limitations:**

Fumex FA1 air cleaners are guaranteed for 24 months from date of invoice to be electrically and mechanically sound. This warranty covers the material and workmanship only. Any defective item will be repaired or replaced, at our option, free of charge provided it has not been misused, abused, or otherwise damaged and is returned PREPAID to:

Fumex, LLC. 1150 Cobb International Pl., Kennesaw, GA 30152

There are no warranties which extend beyond the descriptions set forth in this warranty, notwithstanding any knowledge of Fumex, LLC. regarding the use or uses intended to be made of goods, proposed changes or additions to goods, or any assistance or suggestions that may have been made by Fumex personnel. Customer is responsible for determining the suitability of Fumex products for customer's use or resale, or for incorporating them into objects or applications which customer designs, assembles, constructs or manufactures.

Fumex reserves the right to discontinue any item and to make changes in the specifications, terms and conditions or prices at any time without prior notice. Information furnished in the specifications is believed to be accurate and reliable at time of printing, however Fumex accepts no responsibility for product use, or the effect of future design or specification changes.

***For Assistance or Technical Support please Contact Fumex LLC.***

phone 770-514-7907

fax 770-514-1547

USA toll-free 800-432-7550

[www.fumexinc.com](http://www.fumexinc.com)

**Fumex, LLC.  
1150 Cobb International Place  
Kennesaw, GA USA 30152**

© Fumex, LLC., 2021, all rights reserved.  
Specifications subject to change without notice

## **RELAY ACTIVATION PROCEDURES FOR FA1 UNITS**

1. To activate the relays so the remote feature can be used the software will need to be reprogrammed via a flash drive with a configuration file (*fumex.ini*) and the USB port on the control board. (Contact Fumex to acquire the correct configuration file for your unit).
2. Apply incoming power to the unit by connecting the power cord and turning the power switch located near the power cord on. Make sure the blower is not running and the green power light is off. This is called the “Soft On” state.
3. Reprogramming will lock out the Control Board power button. The ON/OFF function will only be able to be controlled remotely.
4. Copy the *fumex.ini* file onto a flash drive and make sure it is the only file on the flash drive. If anything else is on the flash drive the control board will not know which file to read.
5. Plug the flash drive with the desired *fumex.ini* file into the USB port on the front of the control board. (Make sure the unit is in the “Soft On” state before plugging in the flash drive.)
6. Initially the light above the USB port will be red. After the reprogramming is complete the light above the USB port will turn green and remain lit until the flash drive is removed from the USB port.
7. Remove the flash drive and apply 0-24 VDC to the start relay according to the wiring diagram in Figure 1 to start the unit.

Once the relays have been activated the unit will only start by applying the proper voltage to the start/stop relay.

## **RELAY DE-ACTIVATION PROCEDURES FOR FA1 UNITS**

1. To de-activate the relays so the remote feature cannot be used the software will need to be reprogrammed via a flash drive with a configuration file (*fumex.ini*) and the USB port on the control board. (Contact Fumex to acquire the correct configuration file for your unit).
2. Apply incoming power to the unit by connecting the power cord and turning the power switch located near the power cord on. Make sure the blower is not running and the green power light is off. This is called the “Soft On” state.
3. Reprogramming will unlock the Control Board power button. The ON/OFF function will now be able to be controlled at the unit.
4. Copy the *fumex.ini* file onto a flash drive and make sure it is the only file on the flash drive. If anything else is on the flash drive the control board will not know which file to read.
5. Plug the flash drive with the desired *fumex.ini* file into the USB port on the front of the control board. (Make sure the unit is in the “Soft On” state before plugging in the flash drive.)
6. Initially the light next to the USB port will be red. After the reprogramming is complete the light above the USB port will turn green and remain lit until the flash drive is removed from the USB port.
7. Remove the flash drive and start the unit as described in the “Controls” section.

Once the relays have been de-activated the unit will only start by using the front control panel. All relays will become non-functional.

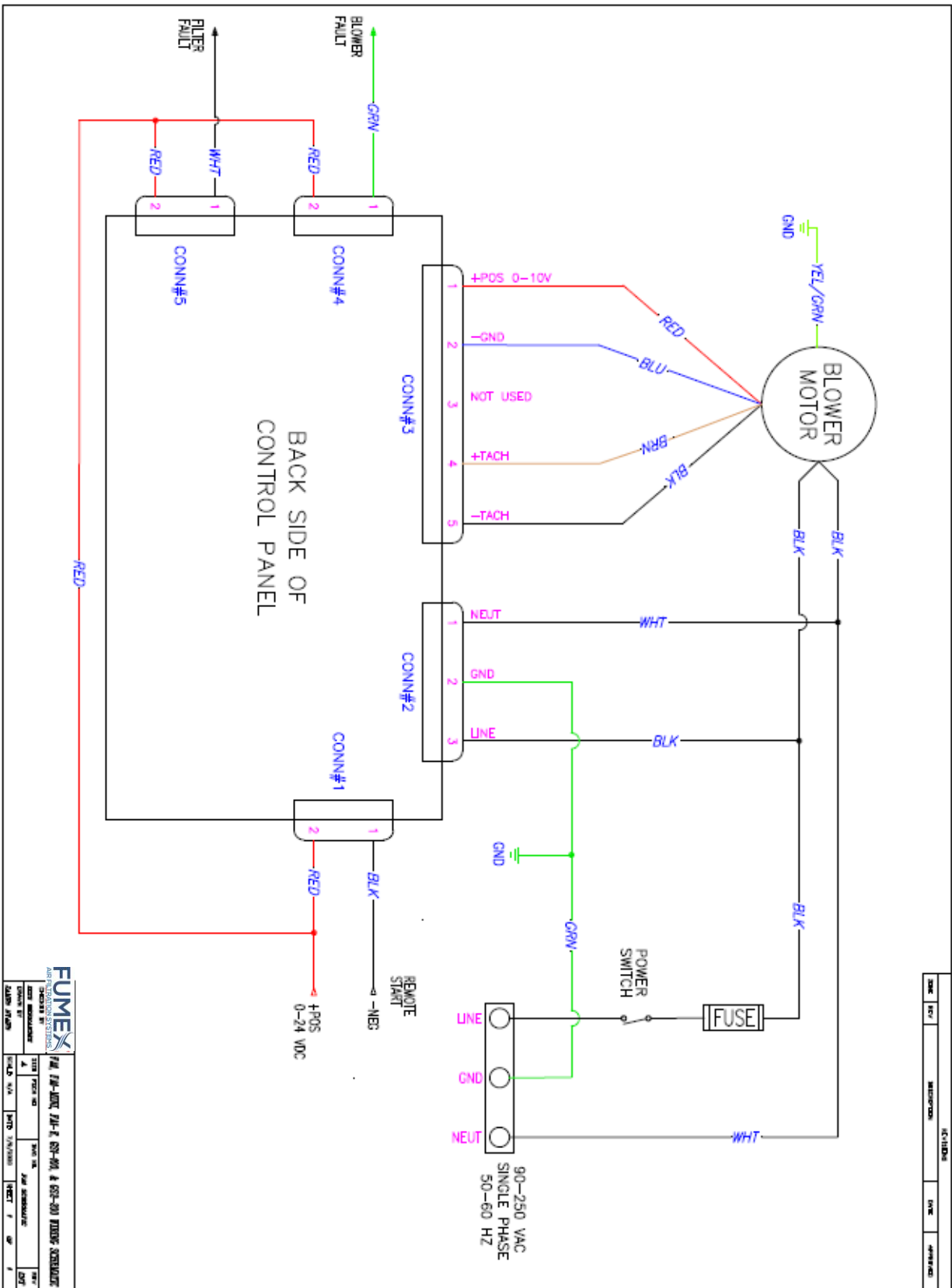

Figure 1