

MAT'L NO.	ENG NO.	MAT'L NO. (TAPE)	ENG NO. (TAPE)	STUD SIZE	"S" ± .005 (0.13)
191170016	A-115-06	---	---	6	.146 (3.71)
191170018	A-115-08	---	---	8	.173 (4.39)
191170020	A-115-10	---	---	10	.198 (5.03)

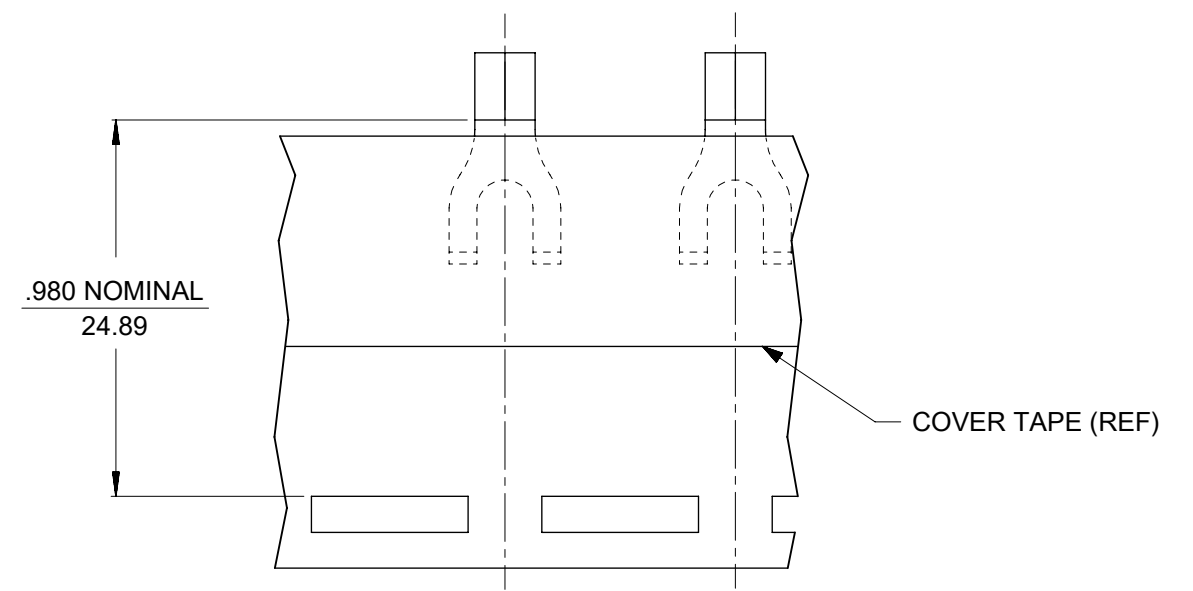
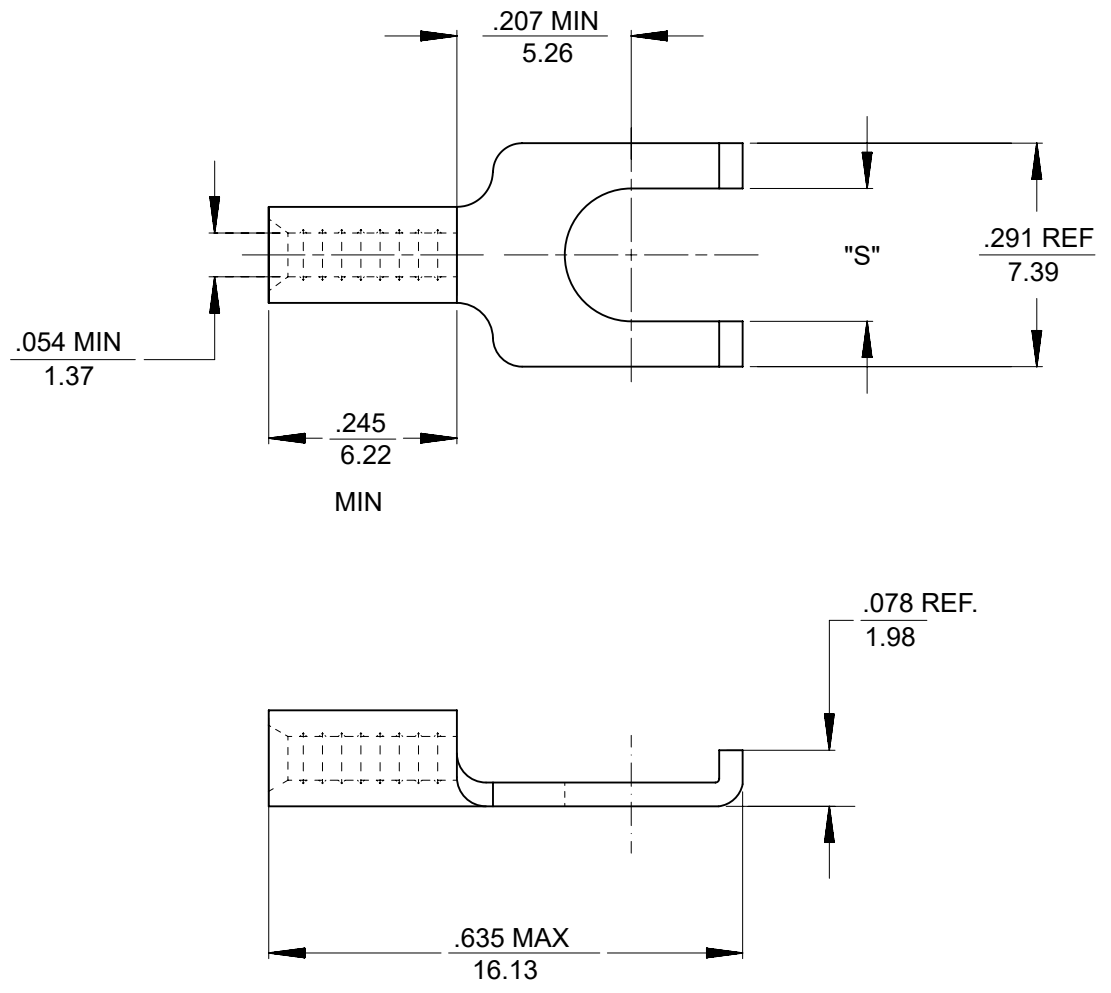

PARTS ON TAPE
191170017 (A-115-06T)

NOTE(S):
 1. MATERIAL: COPPER .031 (0.78) THICK REF.
 2. PLATING: ELECTRO-TIN
 3. PART IS RoHS COMPLIANT

THIS DRAWING CONTAINS INFORMATION THAT IS PROPRIETARY TO MOLEX ELECTRONIC TECHNOLOGIES, LLC AND SHOULD NOT BE USED WITHOUT WRITTEN PERMISSION													
DIMENSION UNITS INCH/MM		SCALE 4:1		CURRENT REV DESC: OBSOLETE PART NUMBERS AS PER PCN#512131.				molex					
GENERAL TOLERANCES (UNLESS SPECIFIED)				EC NO: 727779									
				DRWN: ANIKES1 2022/10/04				FLANGED SPADE TONGUE					
				CHKD: GGA 2022/11/29				TERMINAL KRIMPTITE 22-18 AWG, LONG BARREL					
				APPR: GGA 2022/11/29				PRODUCT CUSTOMER DRAWING					
				INITIAL REVISION:				DOCUMENT NUMBER		DOC TYPE		DOC PART	
				DRWN: RSTONE 2007/11/26				SD-19117-007		PSD		001	
				APPR: JMACNEIL 2007/12/05				REVISION		A2			
ANGULAR TOL ± °				THIRD ANGLE PROJECTION		DRAWING		SERIES		MATERIAL NUMBER		CUSTOMER	
DRAFT WHERE APPLICABLE MUST REMAIN WITHIN DIMENSIONS				B-SIZE		19117		SEE CHART		GENERAL MARKET		SHEET NUMBER	
												1 OF 1	