

May.1.2023 Copyright 2023 HIROSE ELECTRIC CO., LTD. All Rights Reserved.
In case of consideration for using Automotive equipment / device which demand high reliability, kindly contact our sales window correspondents.

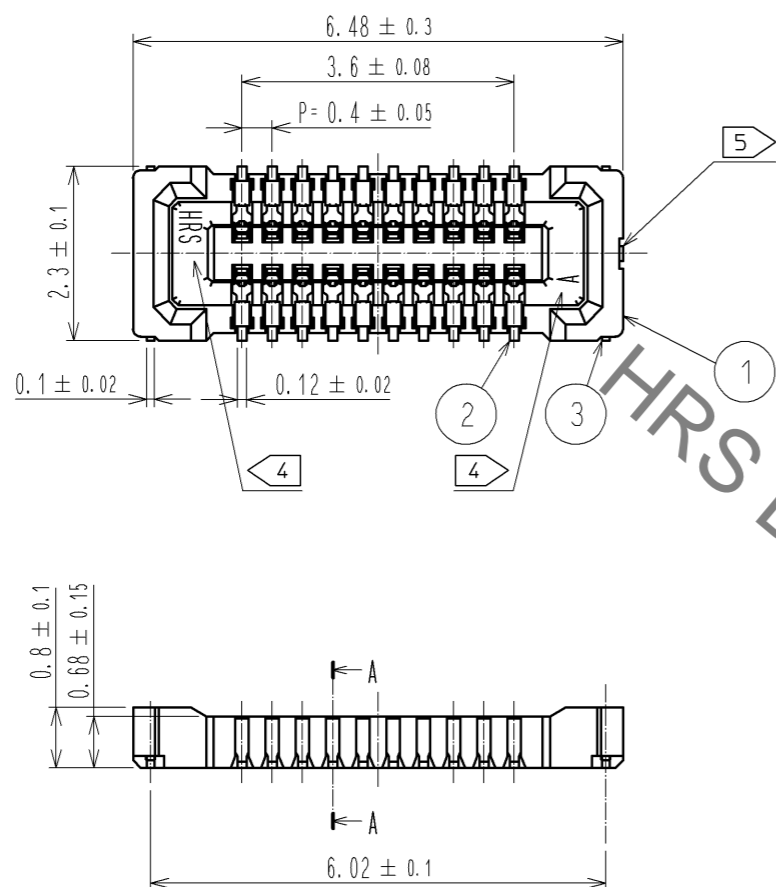

A-A(50:1)

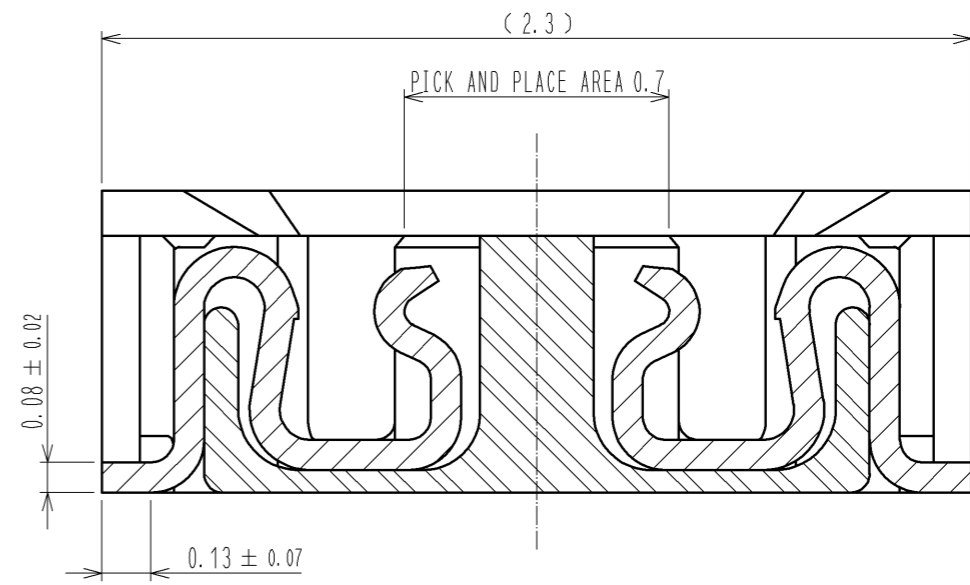

ENGAGEMENT FIGURE (50:1)

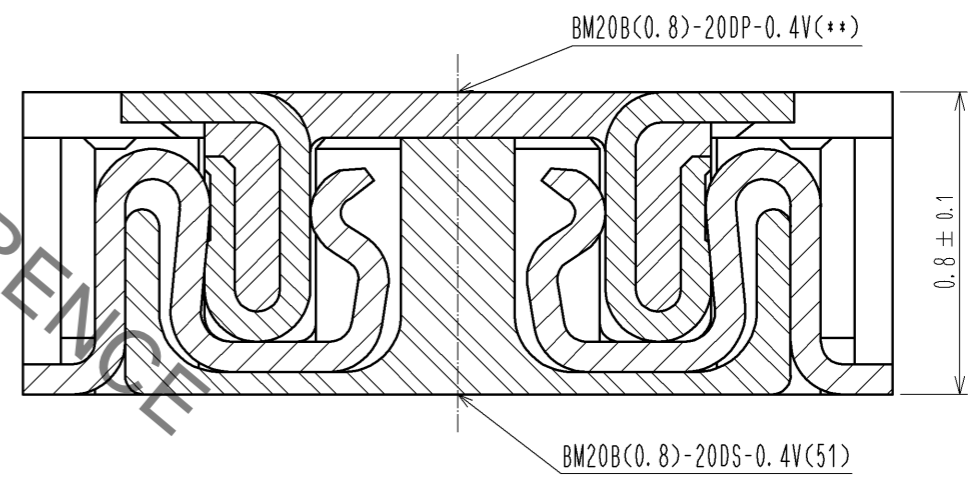

- NOTE 1 . ALL LEAD CO-PLANARITY SHALL BE 0.08mm MAX
- 2 CONTACT PLATING SPECIFICATIONS
CONTACT AREA : GOLD 0.05 μm MIN
SMT LEAD : GOLD 0.05 μm MIN
UNDERPLATING : NICKEL 1 μm MIN
(SURFACE : SEALING)
 - 3 MATAL FITTING PLATING SPECIFICATIONS
SMT LEAD : GOLD 0.05 μm MIN
UNDERPLATING : NICKEL 1 μm MIN
(SURFACE : SEALING)
 - 4 HRS MARK AND CAV NO. ARE INDICATED IN APPROX POSITION SHOWN.
 - 5 GATE POSITION IS INDICATED IN APPROX POSITION SHOWN.

NO.	MATERIAL	FINISH . REMARKS	NO.	MATERIAL	FINISH . REMARKS
4	PS	CLEAR (EMBOSSED CARRIER TAPE)	7	PS	CLEAR (REINFORCEMENT COLLAR)
3	BRASS	3	6	PS	BLACK (PLASTIC REEL)
2	PHOSPHOR BRONZE	2	5	POLYESTER	CLEAR (COVER TAPE)
1	LCP	UL94 V-0, BLACK			

UNITS	SCALE	COUNT	DESCRIPTION OF REVISIONS	DESIGNED	CHECKED	DATE
mm	10:1	△	APPROVED : KH. IKEDA 12.03.02			
			CHECKED : TS. MIYAZAKI 12.03.02			
			DESIGNED : YK. SATAKE 12.03.02			
			DRAWN : KR. AJITO 11.11.02			

DRAWING NO.	EDC3-332315-01
PART NO.	BM20B(0.8)-20DS-0.4V(51)
CODE NO.	CL684-9009-7-51

May.1.2023 Copyright 2023 HIROSE ELECTRIC CO., LTD. All Rights Reserved.
 In case of consideration for using Automotive equipment / device which demand high reliability, kindly contact our sales window correspondents.

◆ RECOMMENDED PCB LAYOUT

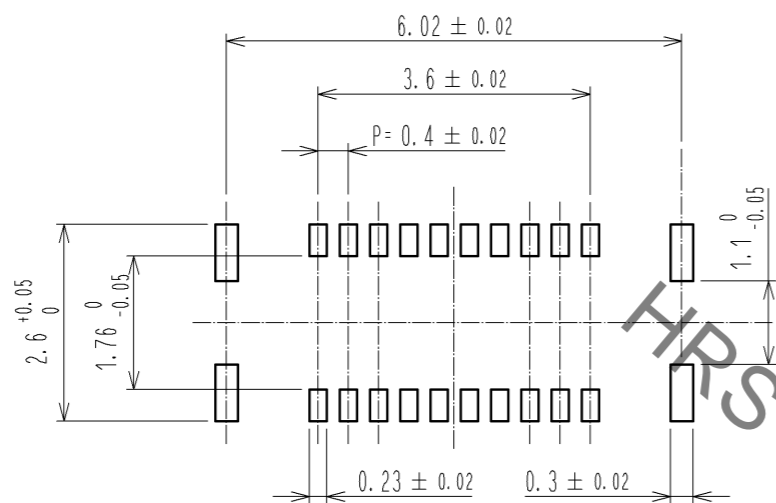

◆ RECOMMENDED METAL MASK DIMENSIONS

MATAL MASK THICKNESS : 100 μm

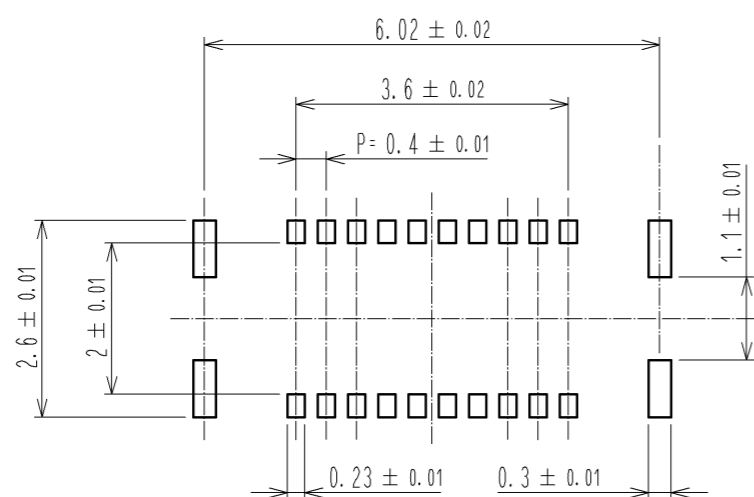

6 RECOMMENDED REFLOW TEMPERATURE PROFILE USING LEAD-FREE SOLDER PASTE.

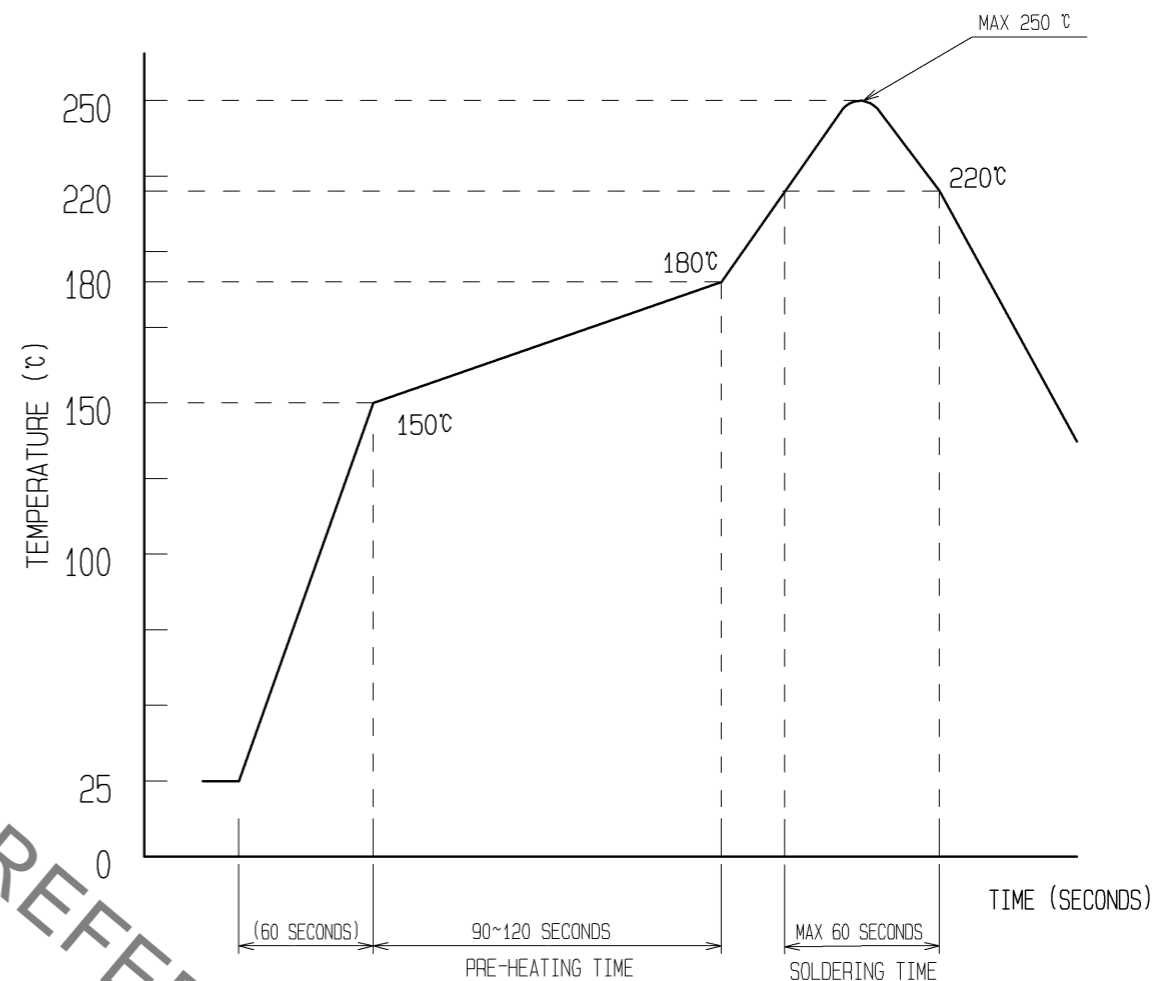

- REFLOW METHOD : IR REFLOW
 NUMBER OF REFLOW CYCLES : 2 CYCLES MAX.
- REFLOW TIME
 DURATION ABOVE 220°C. 60 SEC MAX.
 (PEAK TEMPERATURE : 250°C MAX)
 - PRE-HEAT TIME
 PRE-HEAT TEMPERATURE(MIN): 150°C
 PRE-HEAT TEMPERATURE(MAX): 180°C
 PRE-HEAT TIME: 90-120 SEC.

6 THE TEMPERATURE PROFILE IS PER THE CONDITIONS SHOWN ABOVE. ADDITIONAL FACTORS, SUCH AS SOLDER PASTE TYPE, PCB SIZE AND OTHER MOUNTED COMPONENTS COULD AFFECT THE PROFILE. THEREFORE, A THOROUGH EVALUATION OF MOUNTING CONDITION IS REQUIRED PRIOR TO PRODUCTION. TEMPERATURE IS MEASURED AT CONTACT LEAD.

HRS	DRAWING NO.	EDC3-332315-01
	PART NO.	BM20B(0.8)-20DS-0.4V(51)
	CODE NO.	CL684-9009-7-51

2/3

May.1.2023 Copyright 2023 HIROSE ELECTRIC CO., LTD. All Rights Reserved.
In case of consideration for using Automotive equipment / device which demand high reliability, kindly contact our sales window correspondents.

EMBOSED CARRIER TAPE PACKAGING (5:1)

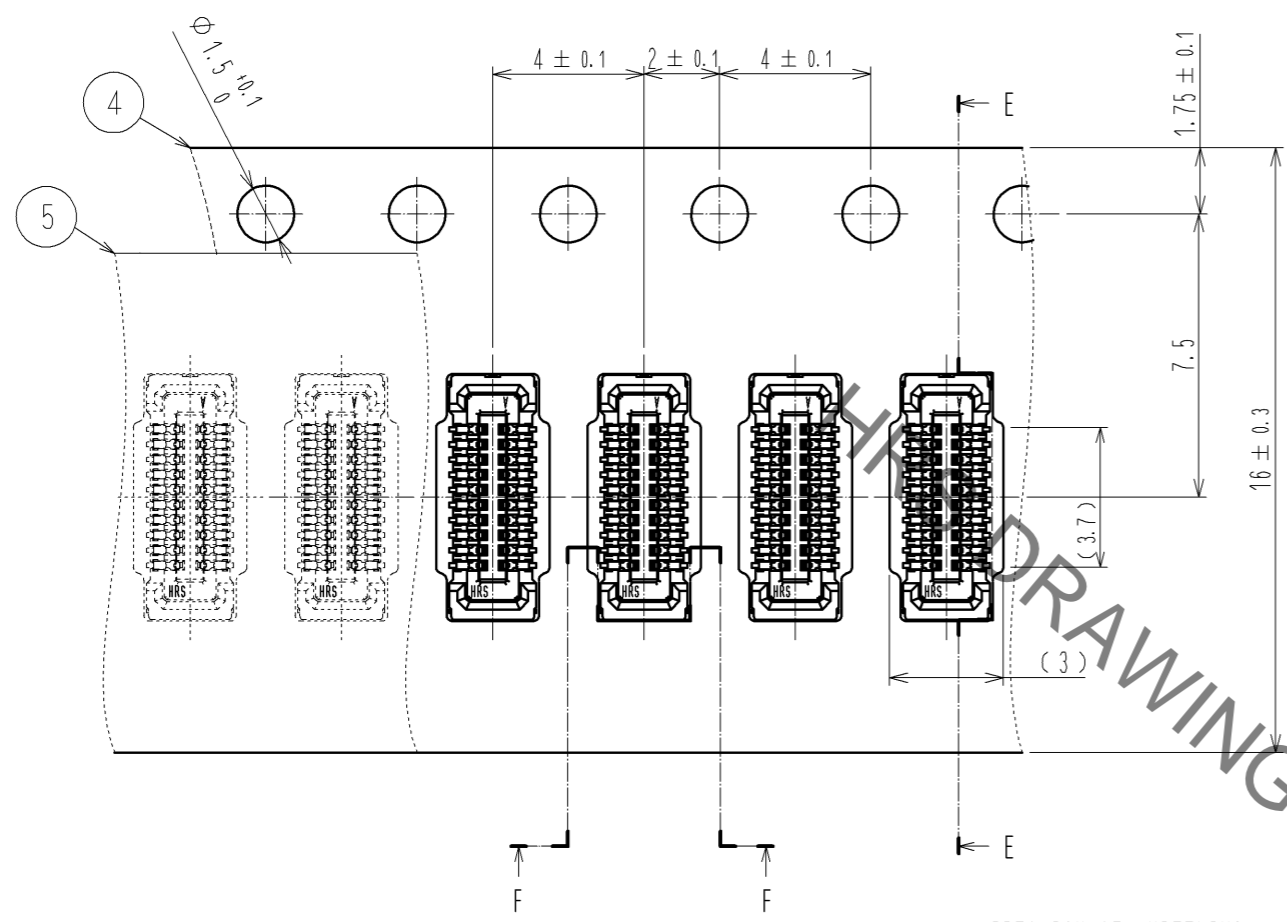

DIRECTION OF UNREELING →

F-F (5:1)

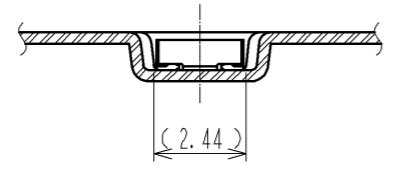

E-E (5:1)

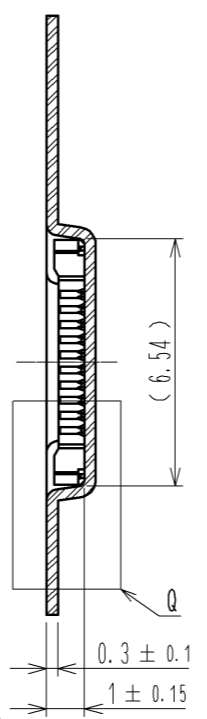

STYLE AND DIMENTION OF REEL (FREE)

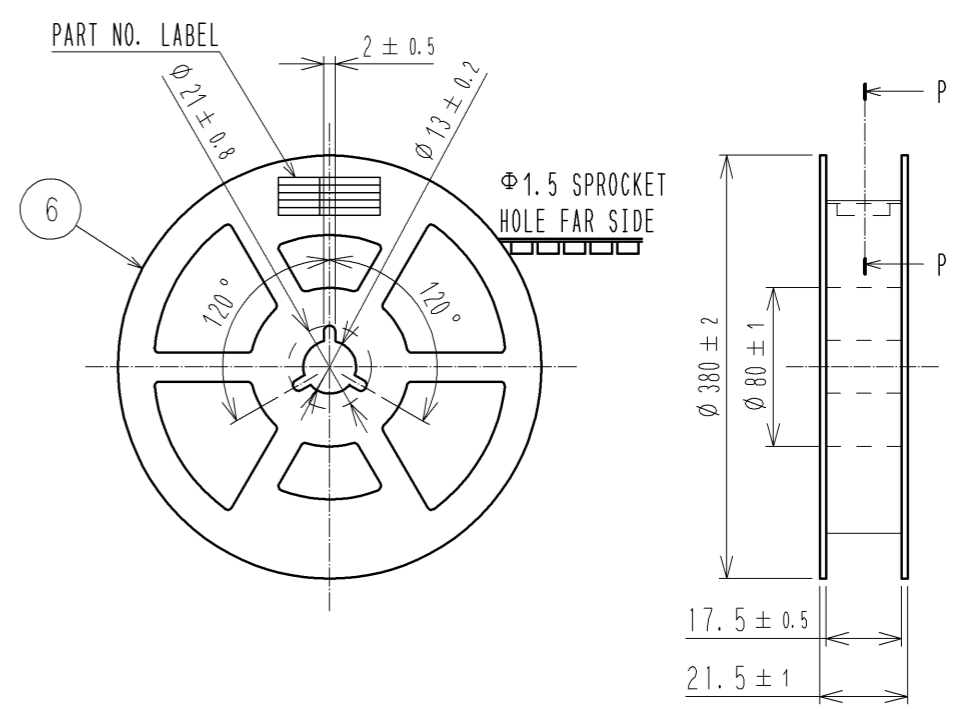

P-P (FREE)

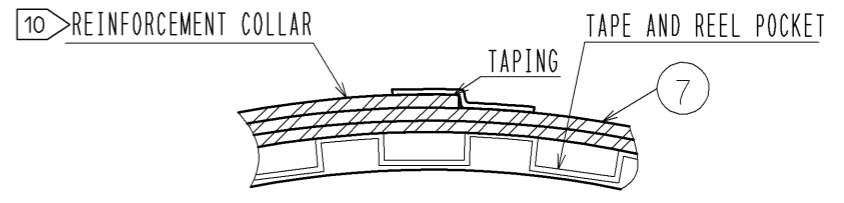

DETAIL OF PART NO. LABEL

製造年月日	** ** *
製品コード	CL0684-9009-7-(51)
製品名	BM20B(0.8)-20DS-0.4V(51)
数量	8,000
納入者	ヒロセ電機(株)

DATA OF MANUFACTURED
CODE NO.
PART NO.
QUANTITY
SUPPLIER

- 7. PER REEL 8000 CONNECTORS.
- 8. THE DIMENSIONS IN PARENTHESSES ARE FOR REFERENCE.
- 9. REFER TO JIS C 0806(PACKAGING OF COMPONENTS FOR AUTOMATIC HANDLING)
- 10. AFTER PACKAGING, ROLL 2 METERS OF THE REINFORCEMENT COLLAR TO OUTER CIRCUMFERENCE OF TAPE AND REEL POCKET. AND TAPE DOWN AT THE END THE COLLAR.

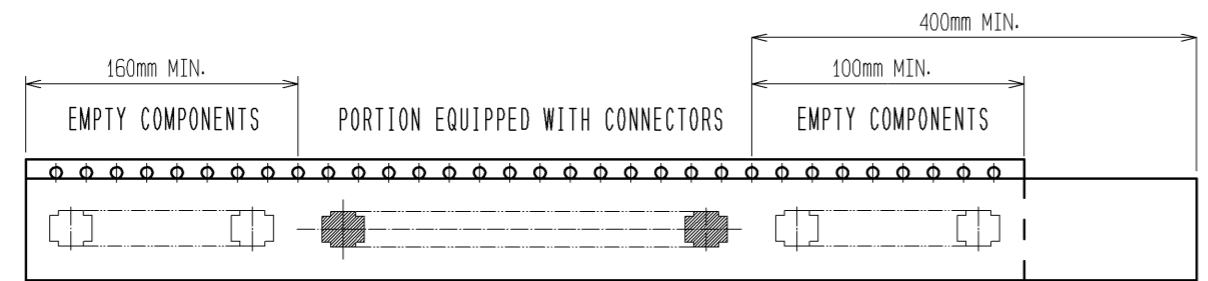

TRAILER

9 TAPING (FREE)

LEADER

Q(10:1)

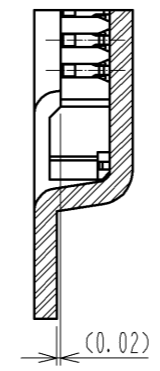

HRS	DRAWING NO.	EDC3-332315-01
	PART NO.	BM20B(0.8)-20DS-0.4V(51)
	CODE NO.	CL684-9009-7-51
		△ 3/3