

May.1.2023 Copyright 2023 HIROSE ELECTRIC CO., LTD. All Rights Reserved.
In case of consideration for using Automotive equipment / device which demand high reliability, kindly contact our sales window correspondents.

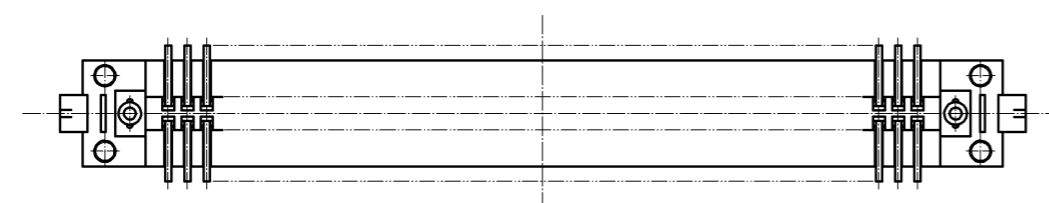
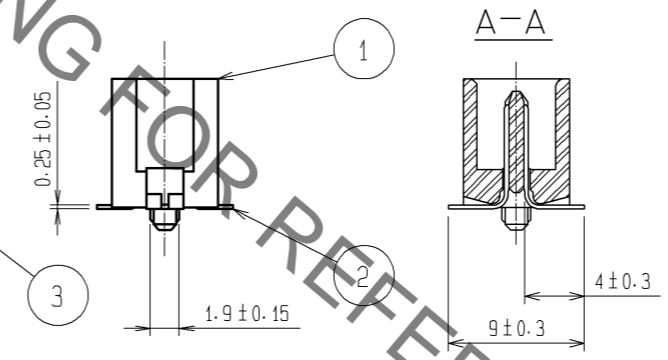
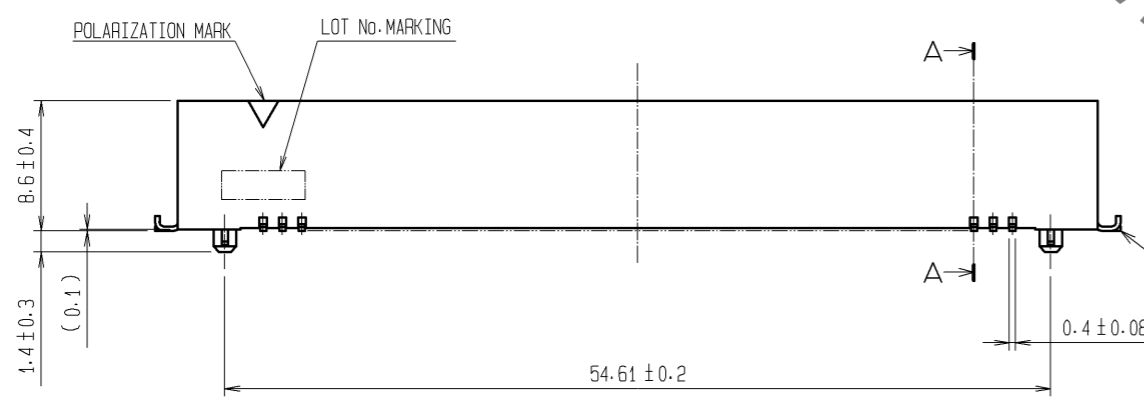
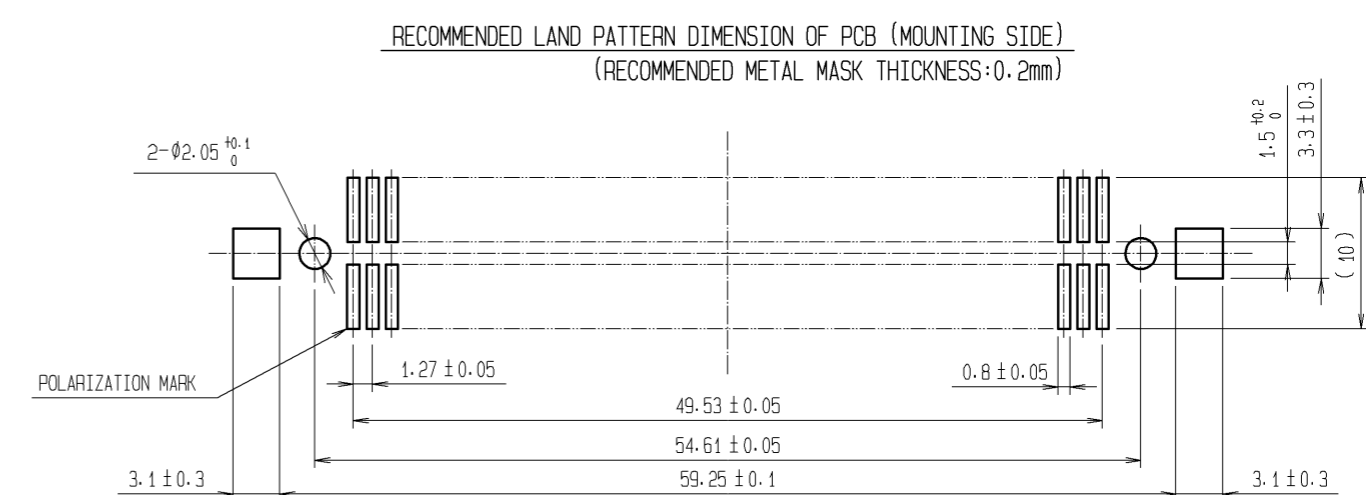
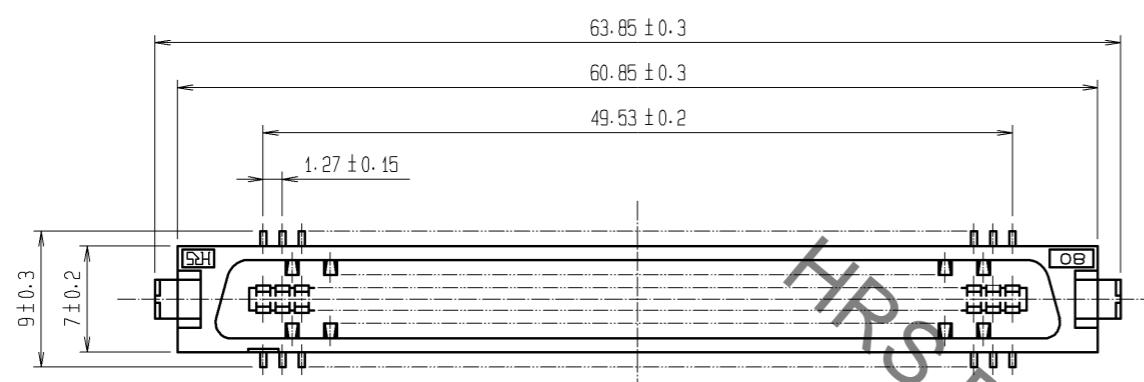

- NOTE
- 1 LEAD CO-PLANARITY SHALL BE 0.15mm MAX.
 - 2 THE DIMENSIONS IN PARENTHESES ARE FOR REFERENCE.
 - 3 TRAY PACKAGING SHALL BE APPLIED TO THIS PRODUCT. SEE NEXT PAGE FOR DETAILS.
 - 4 THIS PRODUCT HAS TAPE FOR VACUUM PICKUP. SEE NEXT PAGE FOR DETAIL OF STICKING POSITION, ETC.

2	PHOSPHOR BRONZE	CONTACT AREA:GOLD 0.2μm min.	5	POLYIMIDE	(TAPE FOR VACUUM PICK-UP)			
		LEAD AREA:TIN-PLATING 2μm min.	4	PS	TRAY			
		UNDER PLATING:NICKEL 2μm min.	3	BRASS	TIN-PLATING			
1	PPS	LIGHT BROWN (UL94V-0)						
NO.	MATERIAL	FINISH . REMARKS	NO.	MATERIAL	FINISH . REMARKS			
UNITS		SCALE	COUNT	DESCRIPTION OF REVISIONS		DESIGNED	CHECKED	DATE
mm		2 : 1						
HRS HIROSE ELECTRIC CO., LTD.		APPROVED : HS. OKAWA	10.08.25	DRAWING NO. EDC3-082409-22				
		CHECKED : HT. YAMAGUCHI	10.08.25	PART NO. FX2-80P-1.27SVL(96)				
		DESIGNED : SY. KAMIGA	10.08.25	CODE NO. CL572-2057-3-96				
		DRAWN : HK. SUNADORI	10.08.25					

May.1.2023 Copyright 2023 HIROSE ELECTRIC CO., LTD. All Rights Reserved.
In case of consideration for using Automotive equipment / device which demand high reliability, kindly contact our sales window correspondents.

DRAWING FOR PACKING(1:2)

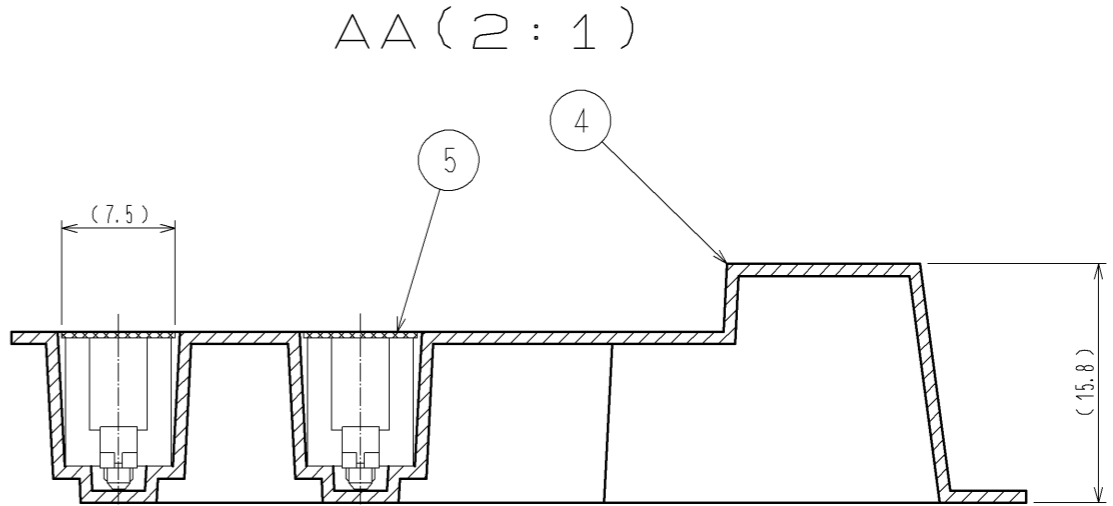
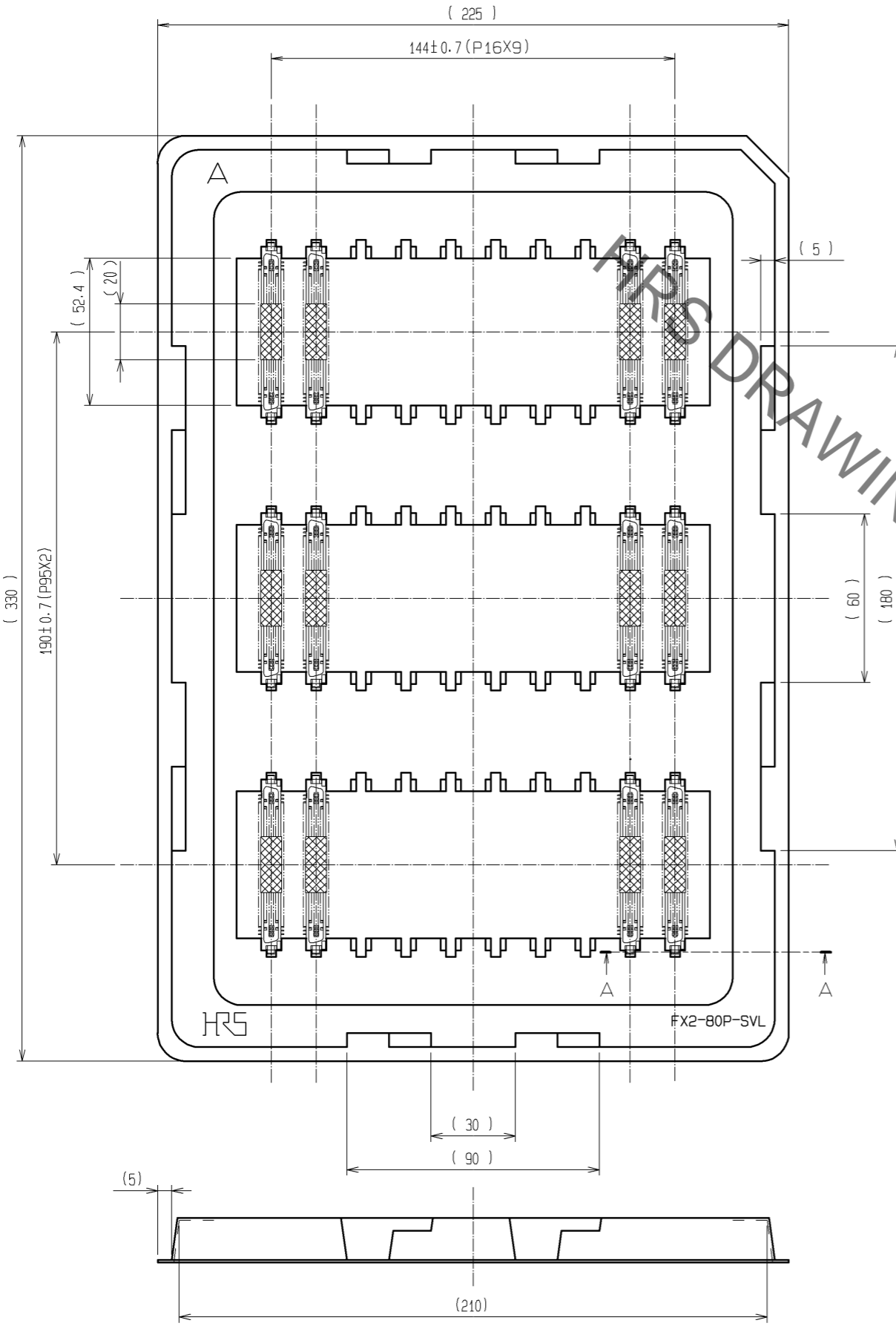

- NOTE
- 1 1 TRAY:30 CONNECTORS
 - 2 SETTING POSITION OF CONNECTORS IN THE TRAY SHALL BE ARRANGED IN ACCORDANCE WITH DRAWING.
 - 3 REMOVE THE VACUUM PICK-UP TAPE AFTER MOUNTING THE CONNECTOR.
 - 4 THE DIMENSIONS IN PARENTHESES ARE FOR REFERENCE.

HRS	DRAWING NO.	EDC3-082409-22
	PART NO.	FX2-80P-1.27SVL(96)
	CODE NO.	CL572-2057-3-96
		△ 2/2