

May.1.2023 Copyright 2023 HIROSE ELECTRIC CO., LTD. All Rights Reserved.
In case of consideration for using Automotive equipment / device which demand high reliability, kindly contact our sales window correspondents.

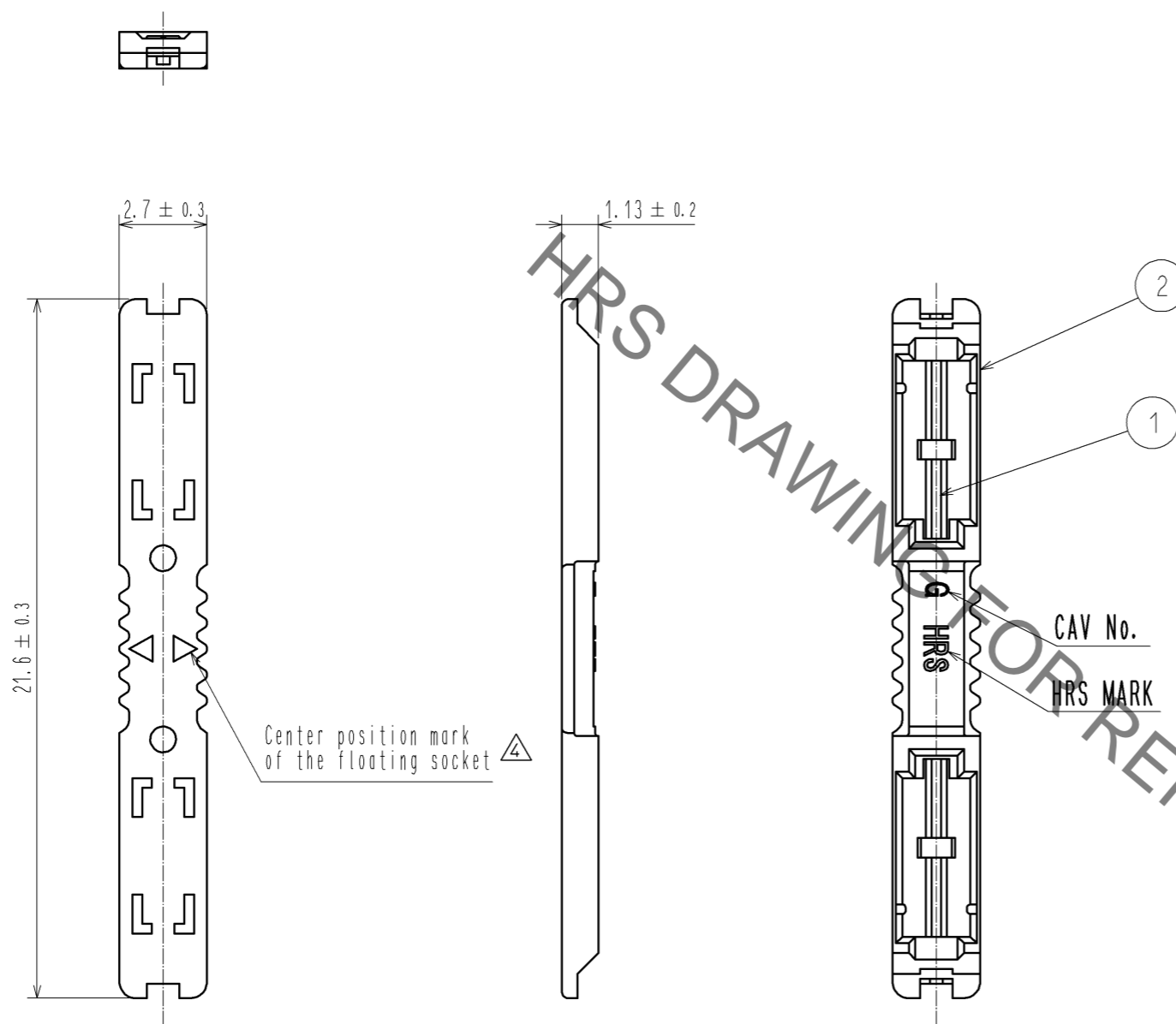

HRS DRAWING FOR REFERENCE

NOTE1. REFER TO THE DF59S SERIES MATING/UNMATING OPERATION INSTRUCTION MANUAL (ETAD-H0651) FOR THE OPERATING OF THE PRODUCT.

2	LCP	UL94V-0, BEIGE	5	PS	REEL, BLACK
1	BRASS	SURFACE:TIN PLATING 1 μ m MIN	4	POLYESTER	CLEAR(COVER TAPE)
		UNDER PLATING:Cu PLATING 0.3 μ m MIN	3	PS	CLEAR(EMBOSSED CARRIER TAPE)
NO.	MATERIAL	FINISH, REMARKS	NO.	MATERIAL	FINISH, REMARKS
UNITS mm		SCALE 5 : 1	COUNT 1	DESCRIPTION OF REVISIONS DIS-H-007568	
			DESIGNED MI. SAKIMURA	CHECKED TS. KUMAZAWA	DATE 13.01.23
HRS HIROSE ELECTRIC CO., LTD.			APPROVED : KI. AKIYAMA	12.06.21	DRAWING NO. EDC3-342886-01
			CHECKED : OM. MIYAMOTO	12.06.21	PART NO. DF59S-1P-FC(21)
			DESIGNED : KT. ISHII	12.06.21	CODE NO. CL667-0023-3-21
			DRAWN : KT. ISHII	12.06.21	1/4

May.1.2023 Copyright 2023 HIROSE ELECTRIC CO., LTD. All Rights Reserved.
 In case of consideration for using Automotive equipment / device which demand high reliability, kindly contact our sales window correspondents.

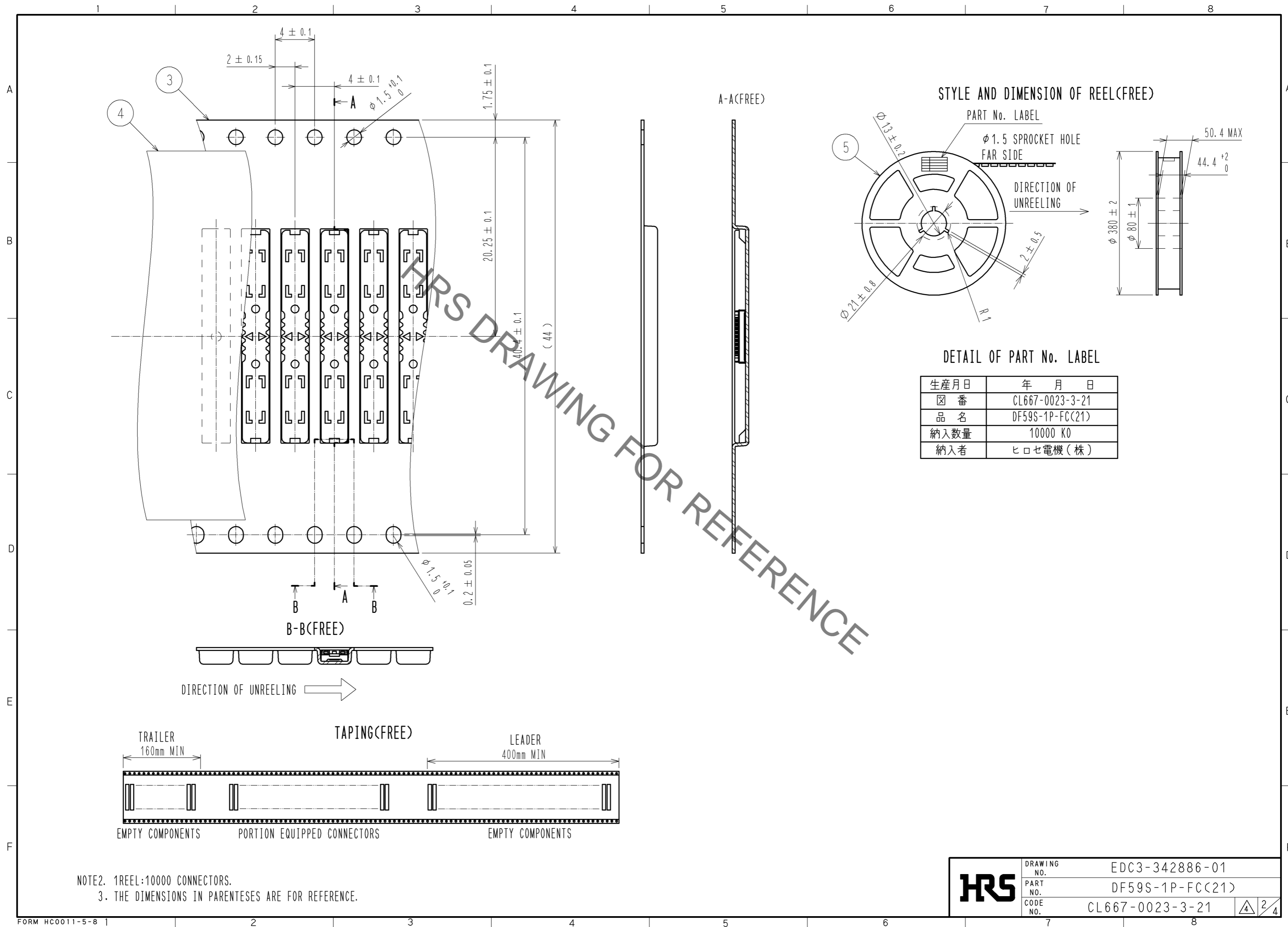

NOTE2. 1REEL:10000 CONNECTORS.
 3. THE DIMENSIONS IN PARENTESES ARE FOR REFERENCE.

HRS	DRAWING NO.	EDC3-342886-01
	PART NO.	DF59S-1P-FC(21)
	CODE NO.	CL667-0023-3-21
		△ 2/4

DF59S Operation Procedures for Floating Socket

«Mating»

1. Place the floating socket at the tip on the receptacle mating point.

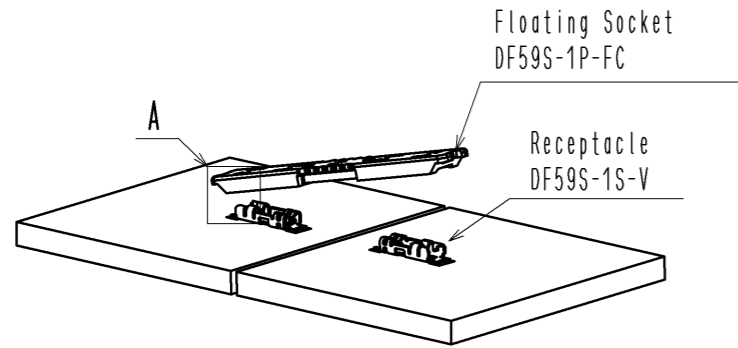

2. Align the center position of floating socket to the center position of the clearance between the facing PCBs in a line.

Press down at the center surface of the floating socket.

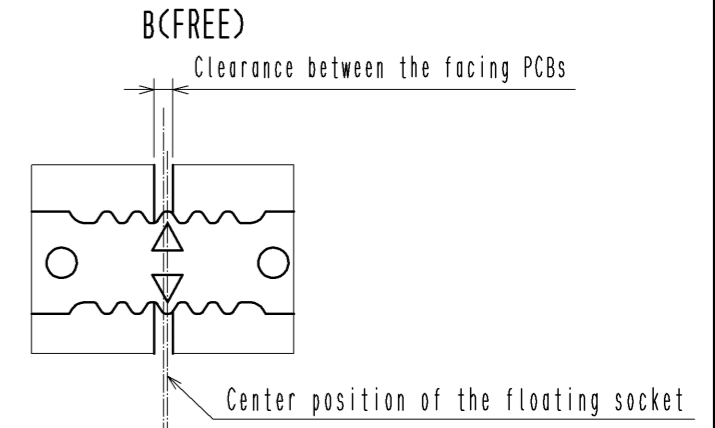
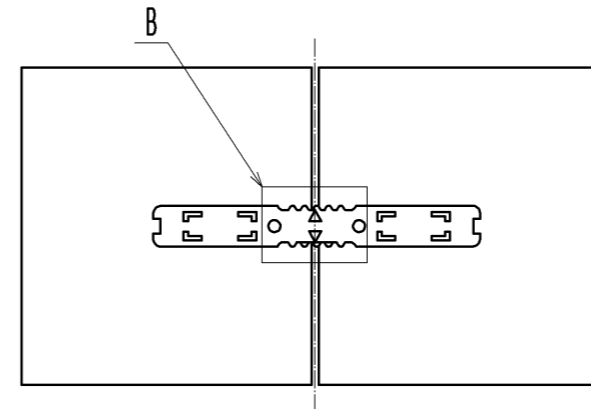

These center positions are in the same line.

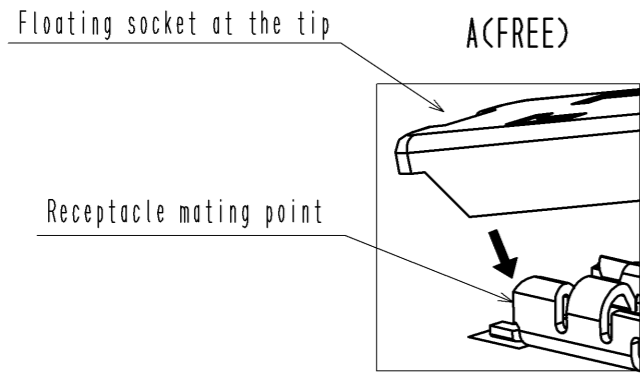

※Floating socket can be mating both directions.

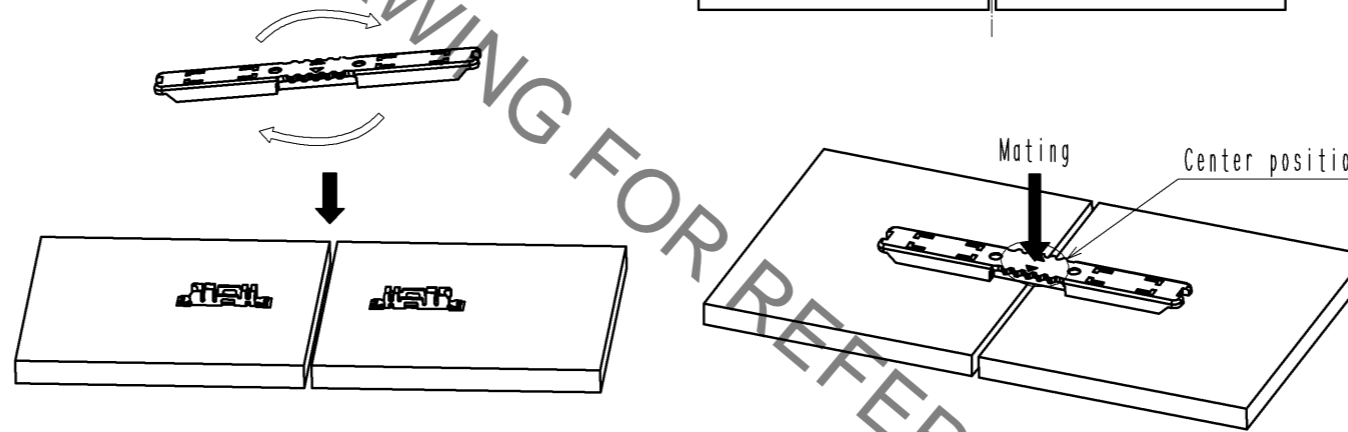

«Unmating»

1. Hook the lever on either sides of floating socket with finger and lift up to the upper direction for unlock. (Lift up until friction lock is released.)

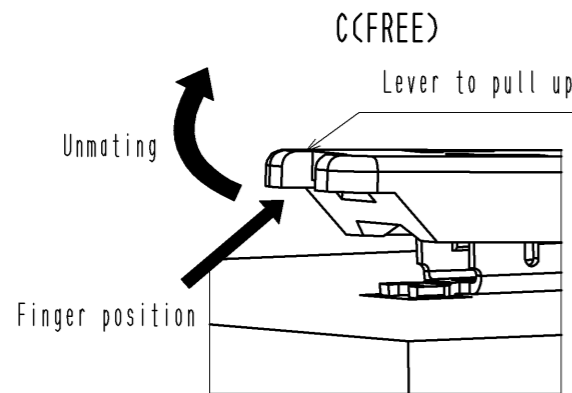
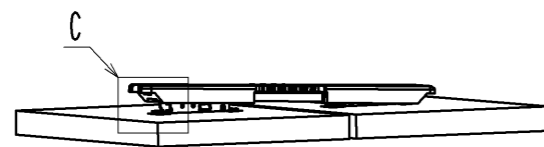

2. After releasing either side, hook the lever on the other side with a finger and lift up to the upper direction, too.

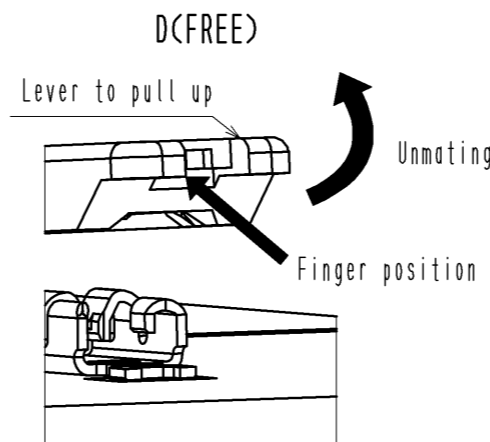
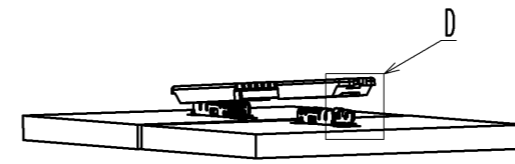

HRS	DRAWING NO.	EDC3-342886-01
	PART NO.	DF59S-1P-FC(21)
	CODE NO.	CL667-0023-3-21
		3/4

May.1.2023 Copyright 2023 HIROSE ELECTRIC CO., LTD. All Rights Reserved. In case of consideration for using Automotive equipment / device which demand high reliability, kindly contact our sales window correspondents.

May.1.2023 Copyright 2023 HIROSE ELECTRIC CO., LTD. All Rights Reserved.
In case of consideration for using Automotive equipment / device which demand high reliability, kindly contact our sales window correspondents.

DF59S Dimension of floating

The dimension of floating at the time of using a floating socket is shown below.
Please use in the limits of dimension.

《Direction of X axis》

The dimension of floating of X direction is shown below.

■ Direction of X axis floating: +0.5mm ■ Normal mating ■ Direction of X axis floating: -0.5mm

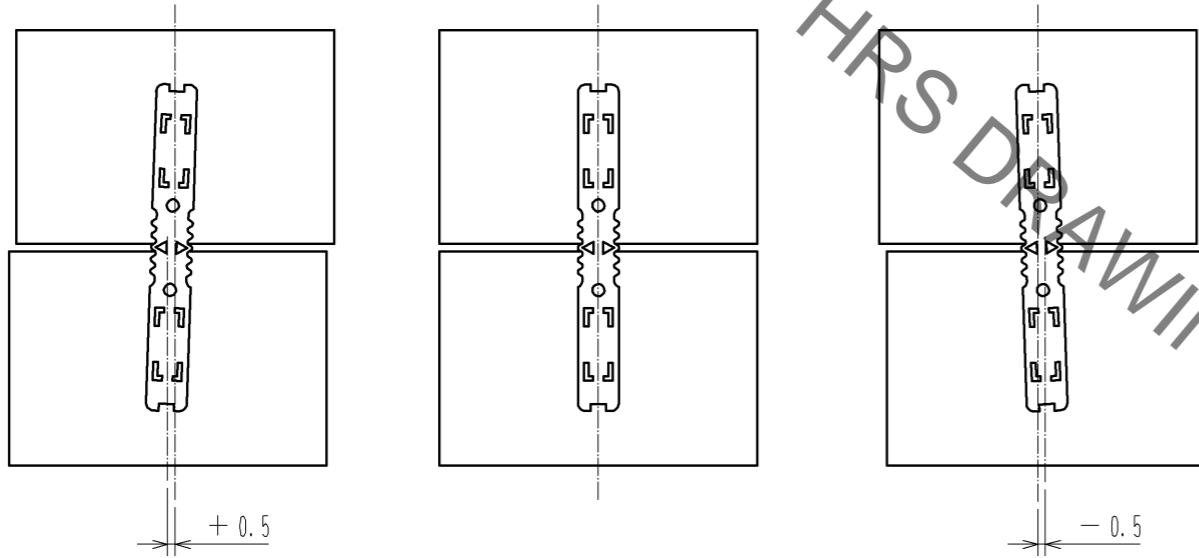

《Direction of Y axis》

The dimension of floating of Y direction is shown below.

■ Direction of Y axis floating: +0.5mm ■ Normal mating ■ Direction of Y axis floating: -0.5mm

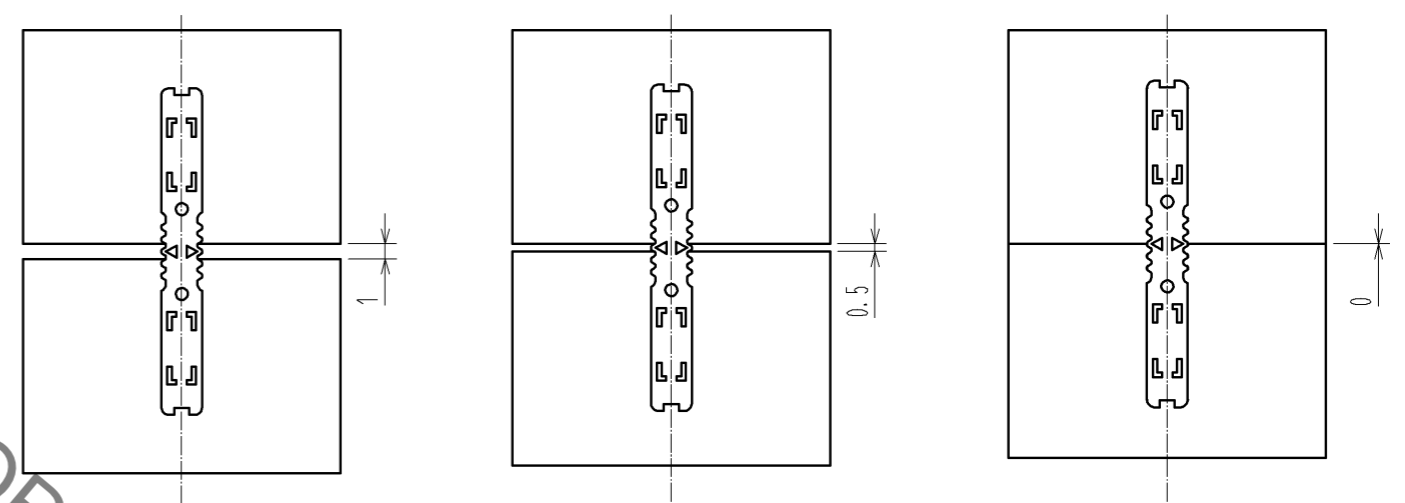

《Direction of Z axis》

The dimension of floating of Z direction is shown below.

■ Direction of Z axis floating: +0.2mm ■ Normal mating ■ Direction of Z axis floating: -0.2mm

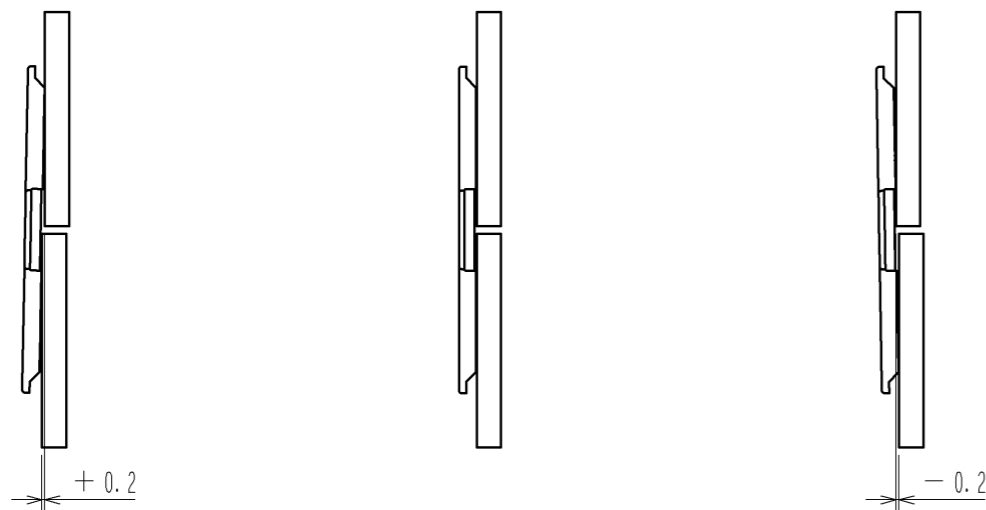

HRS DRAWING FOR REFERENCE



図番:	EDC3-342886-01
製品名:	DF59S-1P-FC(21)
製品コード:	CL667-0023-3-21

