

APPLICATION DIAGRAM(2:1)

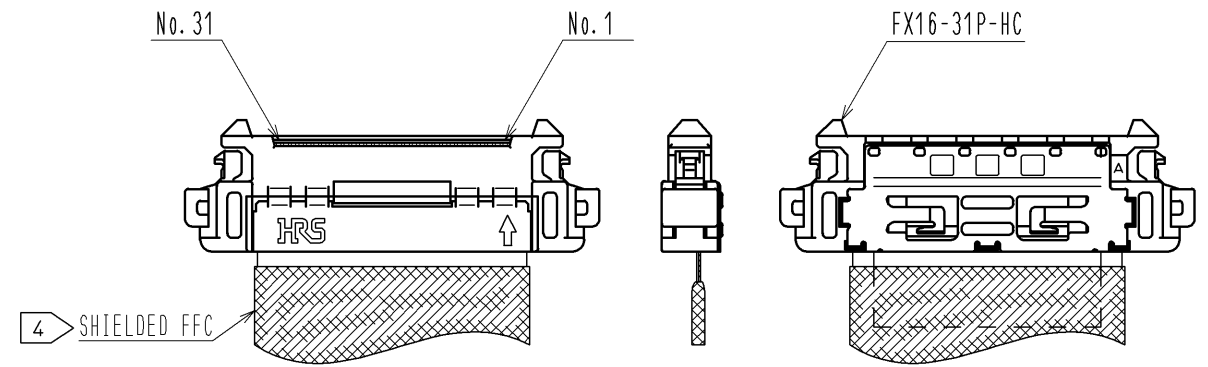

- NOTE 1 () INDICATES A REFERENCE DIMENSION.
 2 MANUFACTURING PROCESS COULD LEAVE SCRATCH AND/OR PUNCH MARKS HAVING NO AFFECT ON THE PRODUCT PERFORMANCE. DARK SPOTS MIGHT OCCASIONALLY OCCUR ON MOLDED PLASTIC.
 3 THE CONNECTORS ARE DELIVERED IN TRAY PACKAGING.
 4 THE APPLICABLE CABLE OF THE CONNECTOR IS SHIELDED FFC.

2	STAINLESS STEEL	NICKEL 0.3µm min.	3	PS	(TRAY)
1	PC	BLACK UL94V-0			
NO.	MATERIAL	FINISH . REMARKS	NO.	MATERIAL	FINISH . REMARKS
UNITS		SCALE	COUNT	DESCRIPTION OF REVISIONS	
mm		4 : 1		DESIGNED	CHECKED
HRS HIROSE ELECTRIC CO., LTD.		APPROVED : HS. OKAWA	10.01.26	DRAWING NO. EDC3-157566-01	
		CHECKED : HT. YAMAGUCHI	10.01.26	PART NO. FX16-31P-HC	
		DESIGNED : SY. KAMIGA	10.01.26	CODE NO. CL575-3242-0-00	
		DRAWN : TS. SHIBUYA	08.05.29		

DRAWING FOR PACKING(1:2)

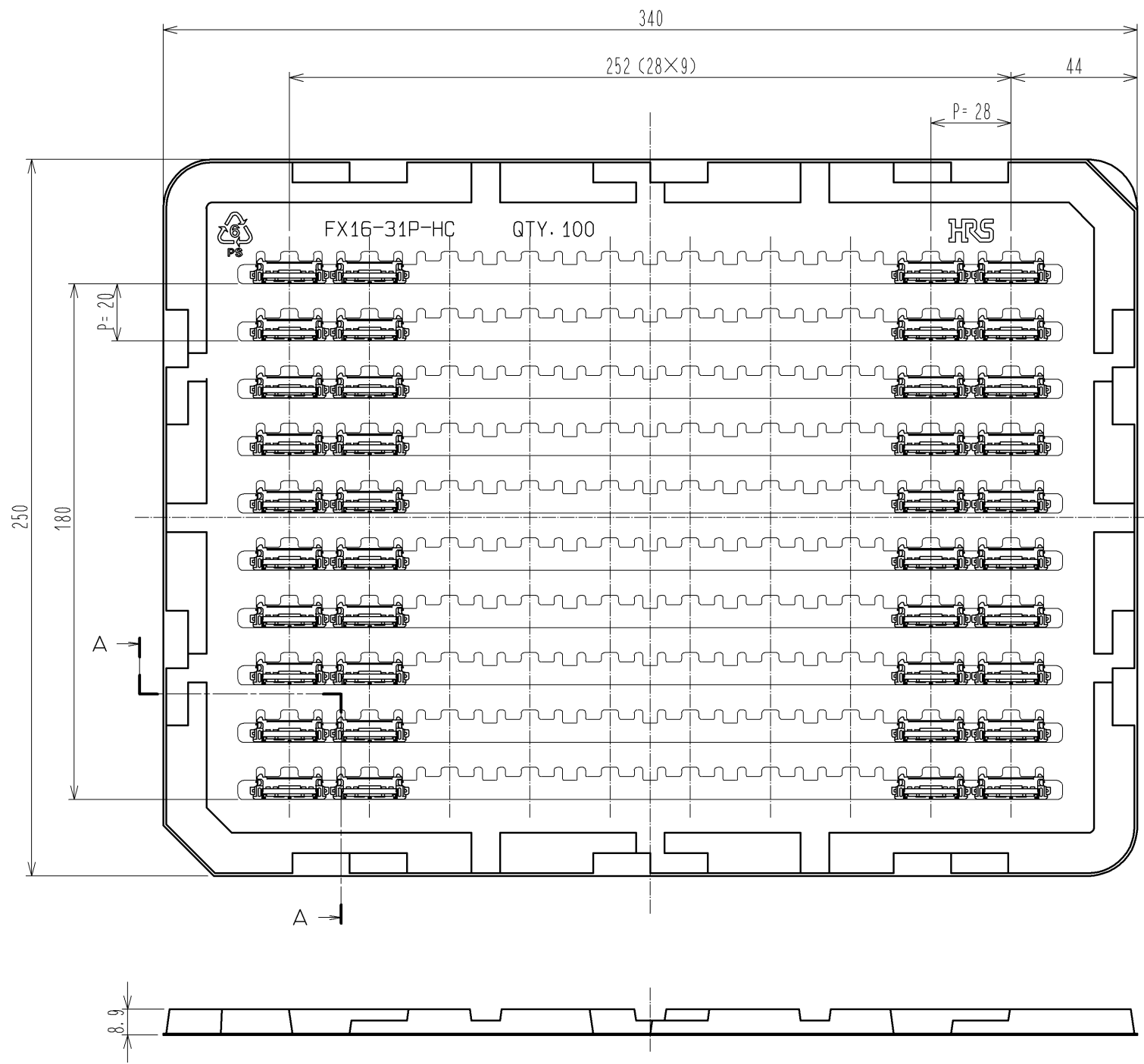

NOTE 1 ONE TRAY CONTAINS 100 CONNECTORS.
 2 THE DIMENSIONS ARE FOR REFERENCE.

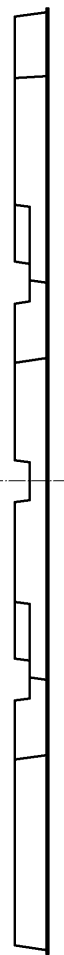

A-A(2:1)

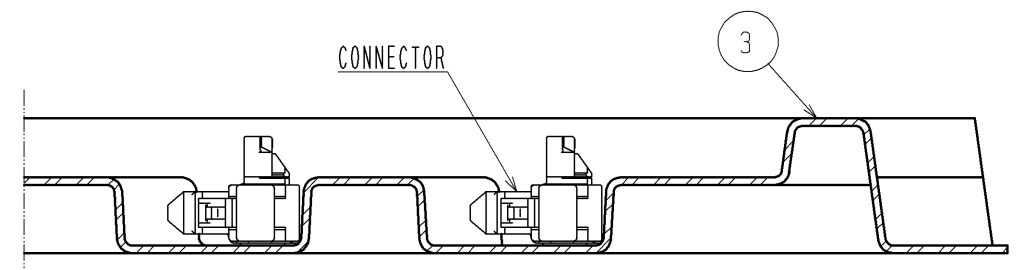

HRS	DRAWING NO.	EDC3-157566-01	
	PART NO.	FX16-31P-HC	
	CODE NO.	CL575-3242-0-00	

HANDLING INSTRUCTIONS

[1] Insertion to on-board connector

The connector mating is keyed. Align the marks as shown in the figure for mating. Insert the connector completely until they are locked at both ends.

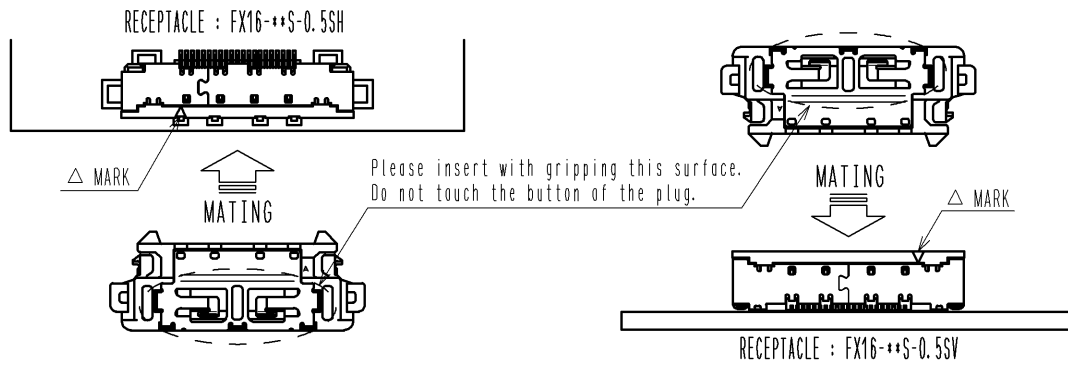

The connectors have a reverse-insertion prevention structure. However, the connectors may be damaged when inserted reversely with the force of 25N or more. Avoid a forceful insertion and make sure to confirm that the connectors are aligned with the marks before the mating operation.

[2] After mating

Carefully wire FFC, so that excessive force will not be applied to the mated connector. Pulling the FFC with the force of 10N or more may damage the connector. It may also cause FFC breakage. Take a caution to avoid pulling the FFC.

Repetitive FFC strokes could also cause FFC breakage as well. Do not use the connector under the environment of repetitive FFC strokes.

Take enough bend radius and/or distance from the connector for FFC not to apply stress to the connector base when the application requires FFC bend back.

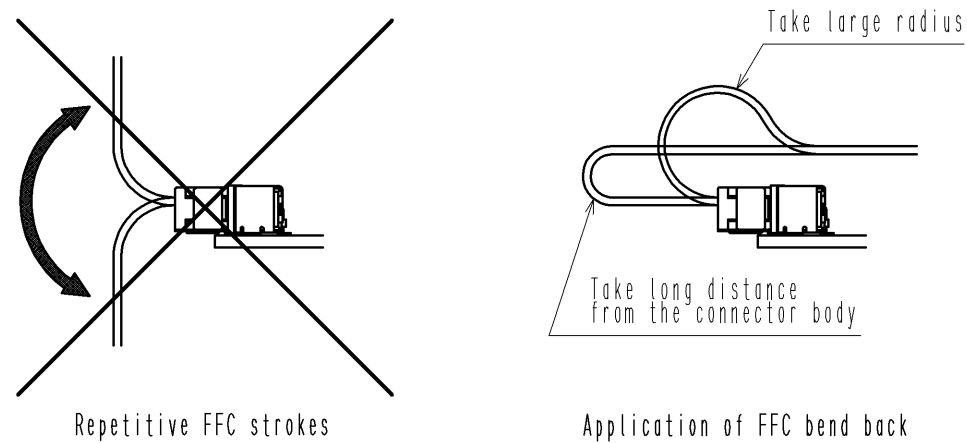

[3] Withdrawal from on-board connector

The connectors are locked while they are mated. In order to unmate the connectors, pull out straight with the button pushed to release the lock. At this time, do not pull the FFC. Also avoid the withdrawal in angle, which may damage the connectors.

<Correct withdrawal>

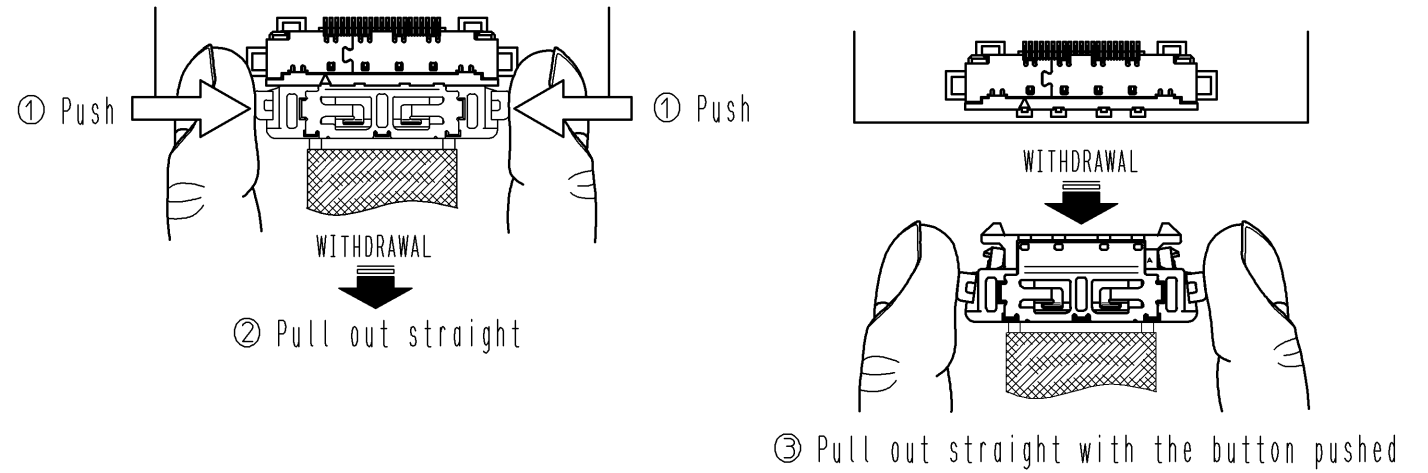

<Incorrect withdrawal>

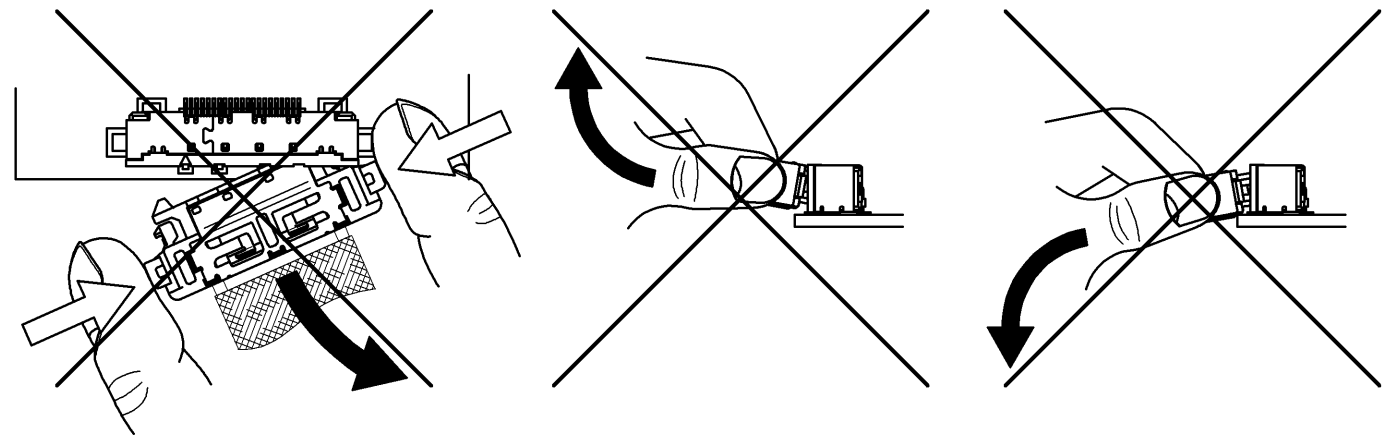

[4] For the case that connector is withdrawn in condition that lock on one side is locked

In case connector is withdrawn in condition that lock on one side is locked, it could damage the locking part. In such case, do not withdraw forcefully, but mate the plug again and pull out the plug in condition that the two locks are locked and withdraw with <Correct withdrawal> method.

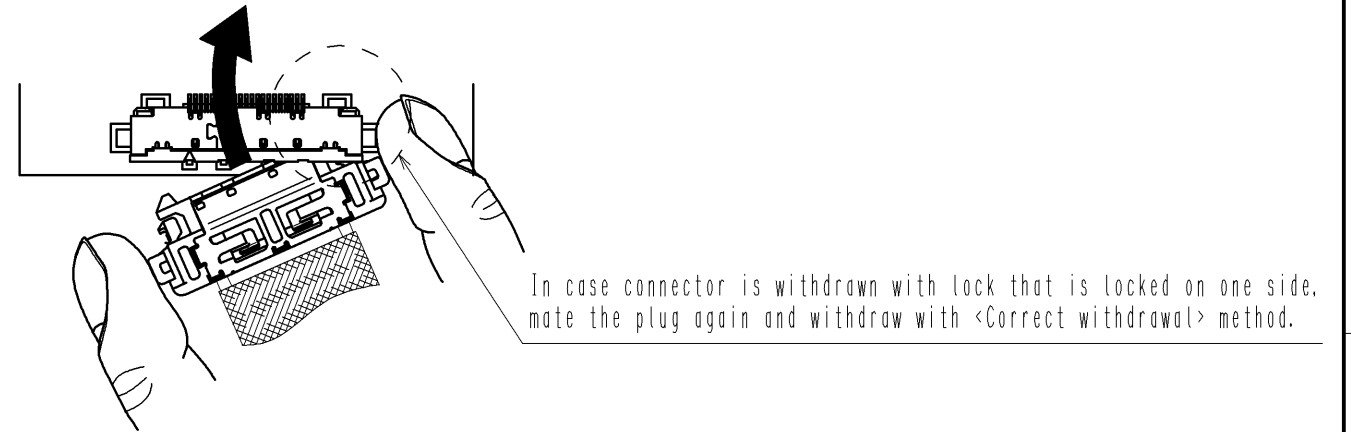

In case connector is withdrawn with lock that is locked on one side, mate the plug again and withdraw with <Correct withdrawal> method.

*Note : The connectors shown in this 'HANDLING INSTRUCTIONS' are drawn for the instruction purpose. Therefore, the appearance differs from the actual connectors. Please confirm the connector configuration on the connector drawing (SHEET 1).

HRS	DRAWING NO.	EDC3-157566-01
	PART NO.	FX16-31P-HC
	CODE NO.	CL575-3242-0-00
		△ 3/5

Please read the notification below before handling the connector.

PRECAUTION FOR HARNESS

*Please make sure not to touch conductor of FFC.

[1] How to insert FFC

FFC needs to be inserted straight in alignment with mold lib as shown on illustration below.
 In case FFC is inserted wrong direction, FFC can not be inserted.
 In the worst case, FFC will be deformed, plastic housing, spring terminal will be broken, so please be aware of these points.

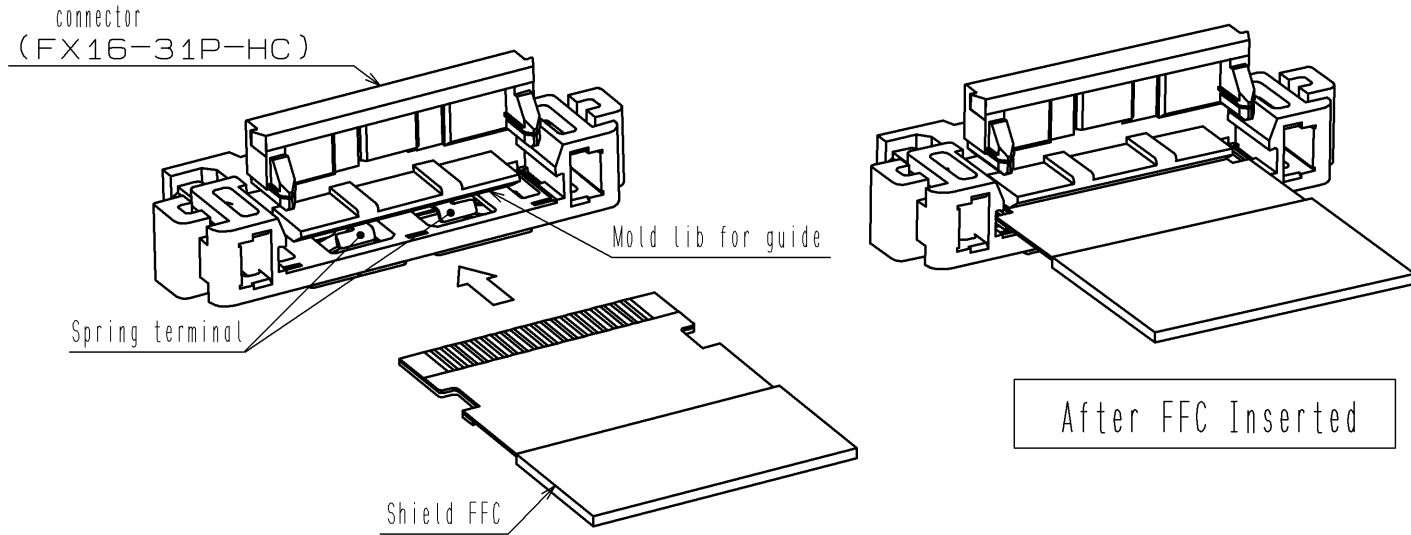

[2] How to check FFC inserted position

Verify that the position of FFC end face from directly above to check whether FFC inserted to correct position
 When inserted correctly, the end of FFC is visible through the square holes in the plastic housing.
 *Please check that the end of FFC hits the wall of the plastic housing.

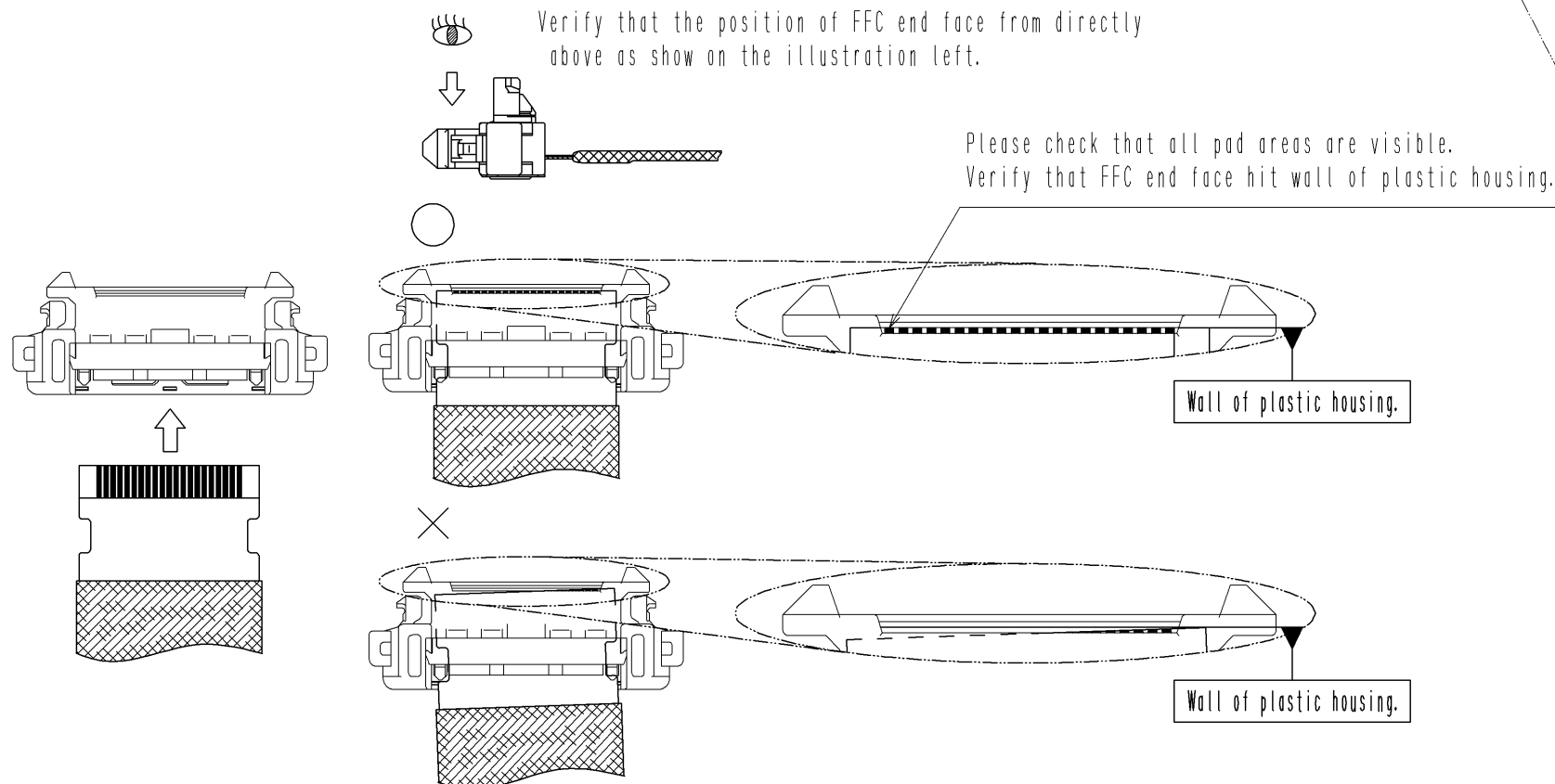

[3] How to fix FFC

Close hinged actuator as show on the illustration below.
 Verify that the fittings at both side hook completely.

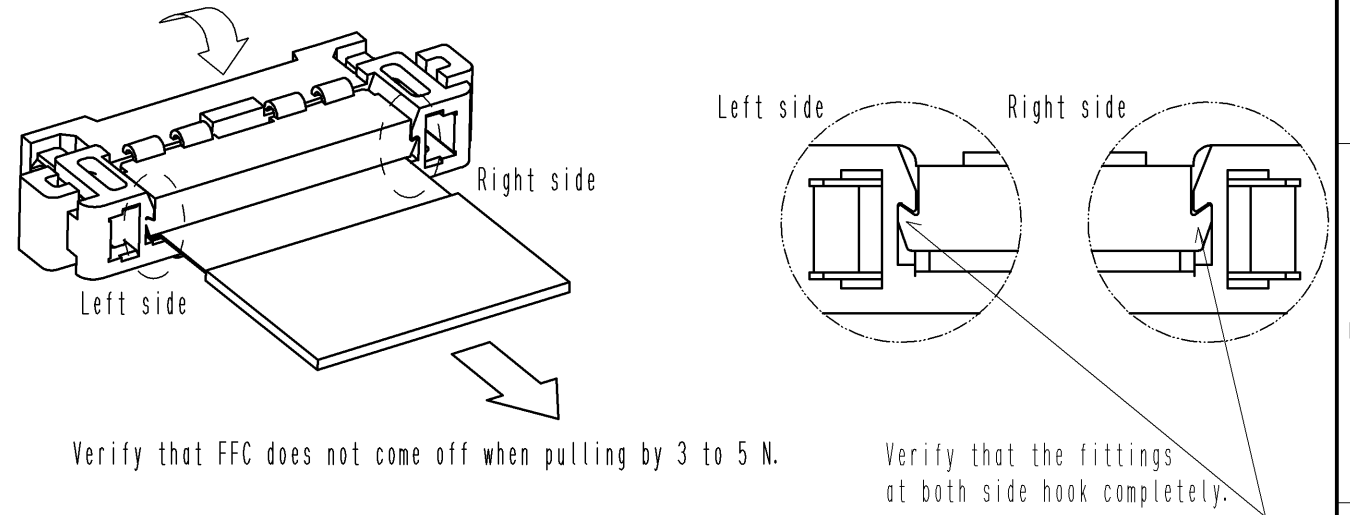

Verify that FFC does not come off when pulling by 3 to 5 N.

After closing hinged actuator, holding both side of plastic housing and pulling FFC to FFC layout direction by 3 to 5N, then verify that no FFC coming off from plastic hosing and fittings at both side hook completely.

[4] Position of contact point after assembly of FFC

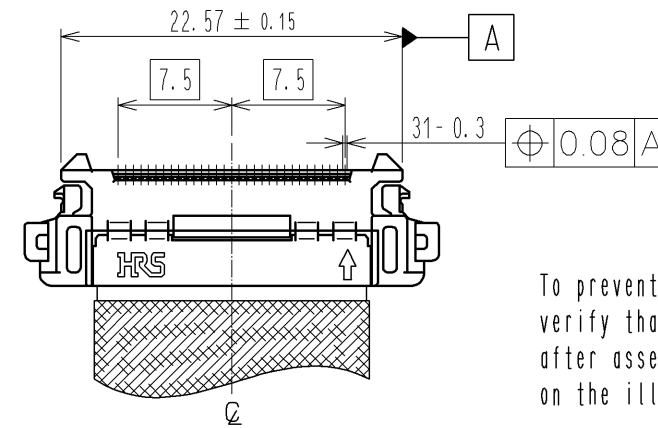

To prevent misalignment of contact pitch, verify that the position of FFC contact point after assembly is within dimension as shown on the illustration.

*Note : The connectors shown in this 'PRECAUTION FOR HARNESS' are drawn for the instruction purpose. Therefore, the appearance differs from the actual connectors. Please confirm the connector configuration on the connector drawing (SHEET 1).

[5] Other precautions

① Do not apply forces to the hinged actuator to the direction as shown below, and also avoid closing it to the locked position until the correct process in cable assembly. Do not use the connector when this happens.

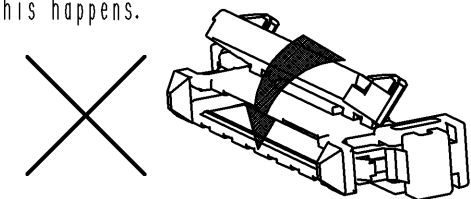

② Once removing the FFC from the plug housing after cable assembly, do not reuse.
 ③ For the packing of the plug after cable assembly, do not damage and/or deform the product.

HRS	DRAWING NO.	EDC3-157566-01
	PART NO.	FX16-31P-HC
	CODE NO.	CL575-3242-0-00
		△ 4/5

RECOMMENDED FFC DIMENSION

A (20:1)

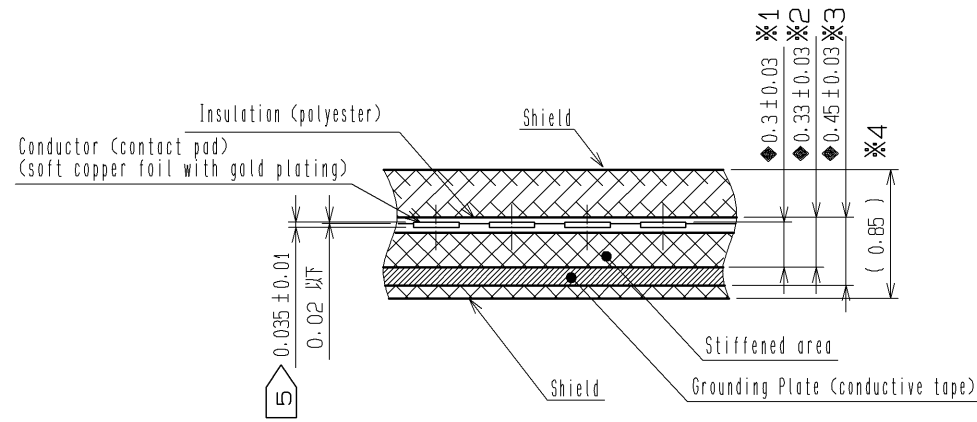

B (20:1)

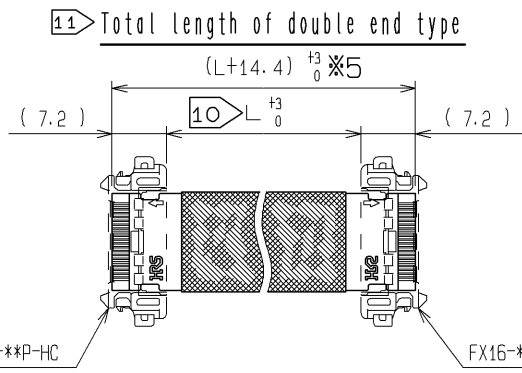
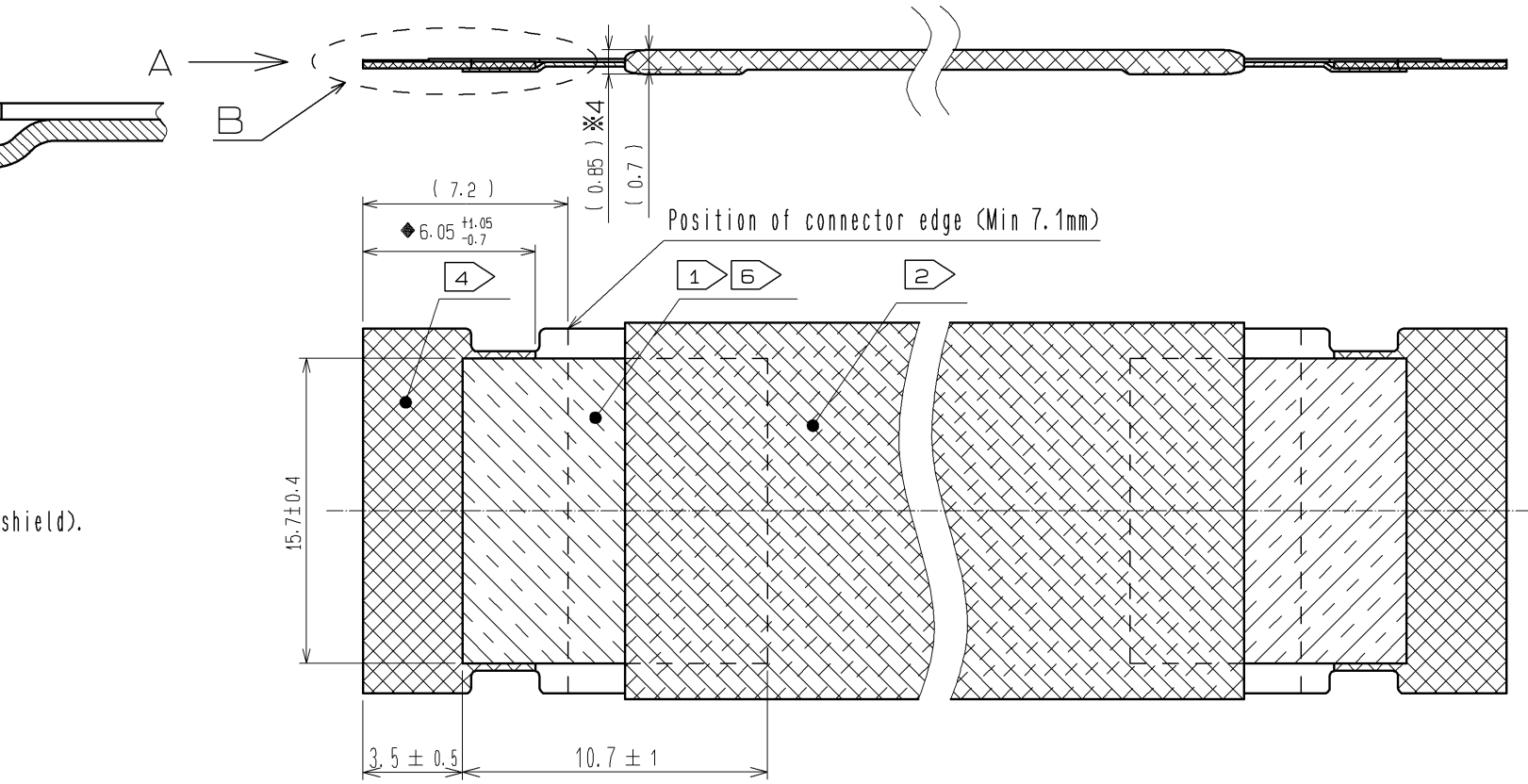
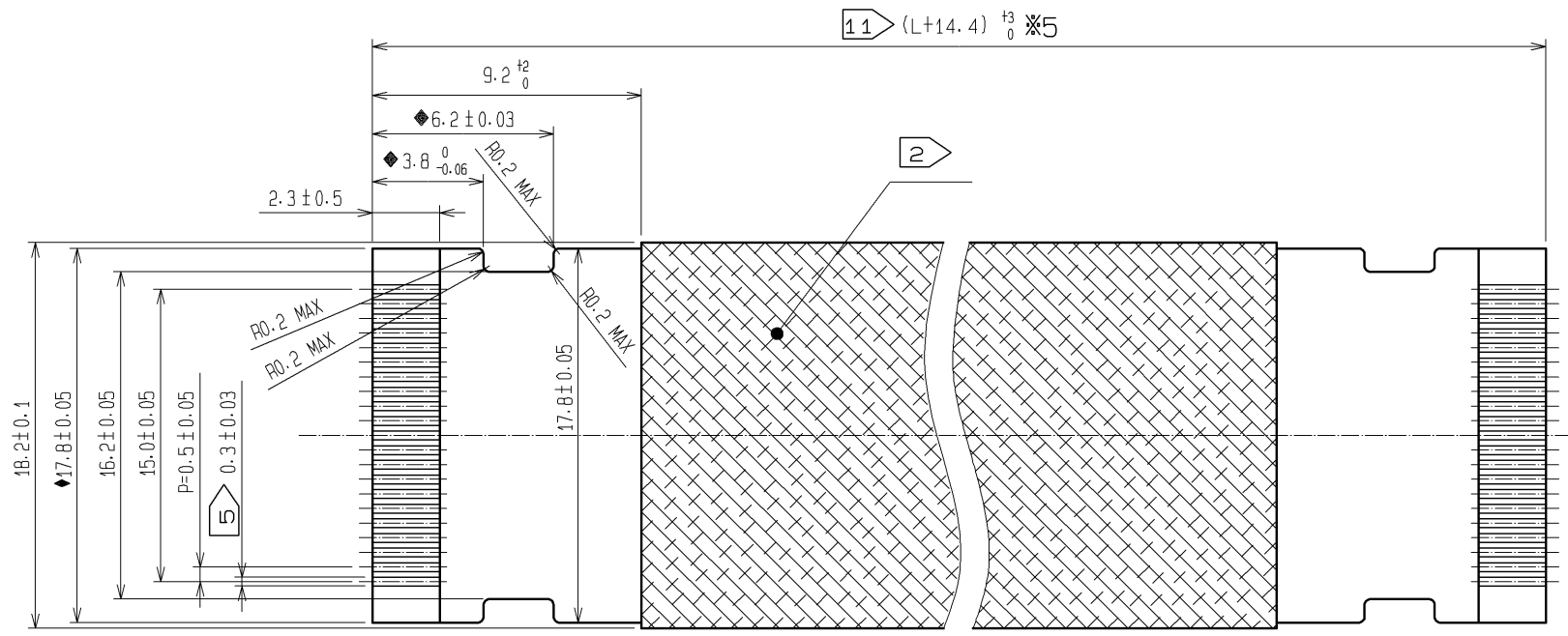
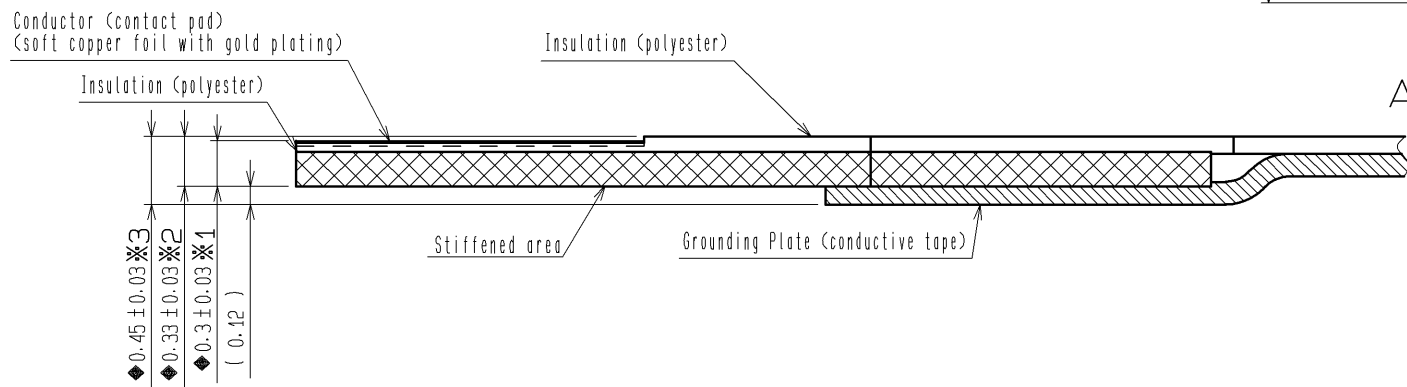

- ① The plating of ground plate (tape) should be 'Sn' plating (more than 1.5 micrometer). The plating of contact pad should be 'Au' plating over 'Ni' plating..
 'Ni' plating for base (from 1 to 5 micrometer)
 'Au' plating for surface (more than 0.2 micrometer)
- ② This area shows 'Shielding Area' (Picture in this drawing show example of double shield).
- ③ This area shows 'Grounding plate area (conductive tape)'
 Also, sticking surface at both end of FFC should be same side.
- ④ This area shows 'Stiffened film area'.
- ⑤ Thickness of each pad (conductor of FFC) should be 0.035 ± 0.01 mm, and width of each pad (conductor of FFC) should be 0.3 ± 0.03 mm.
- ⑥ The shielding should be laid on the ground plate (tape). Please make sure if there is conductivity between the ground plate (tape) on one side of the FFC and the other.
- 7 The differential impedance of this FFC should be $100 \text{ ohm} \pm 7\%$.
- 8 The rated current of this FFC should be 0.5A per pad.
 The rated voltage of this FFC should be 60V.
 The upper temperature limit of this FFC should be 105 degrees Centigrade.
- 9 When dimensions are written in (), it means they are 'Dimensions for reference'.
 When dimensions are written with ※, it means they are 'Duplicated dimensions'.
 When dimensions are written with ◆, it means they are 'Important dimensions'.
- ⑩ Dimension L is the cable length between the cable exit of each connector.
- ⑪ Total length of FFC is 'connector length 7.2mm' x 2 + L mm.

HRS	DRAWING NO.	EDC3-157566-01
	PART NO.	FX16-31P-HC
	CODE NO.	CL575-3242-0-00
		△ 5/5