

LOC		DIST		REVISIONS					
AF		50		P	LTR	DESCRIPTION	DATE	DWN	APVD
				J1		REVISED PER ECO-15-000201	07JAN15	JR	PD

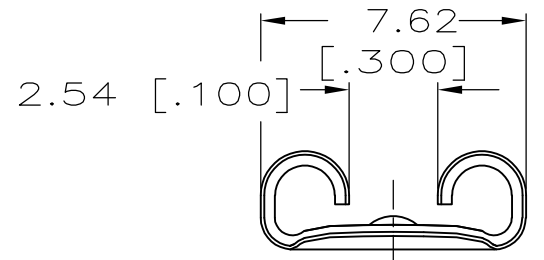

VIEW A-A

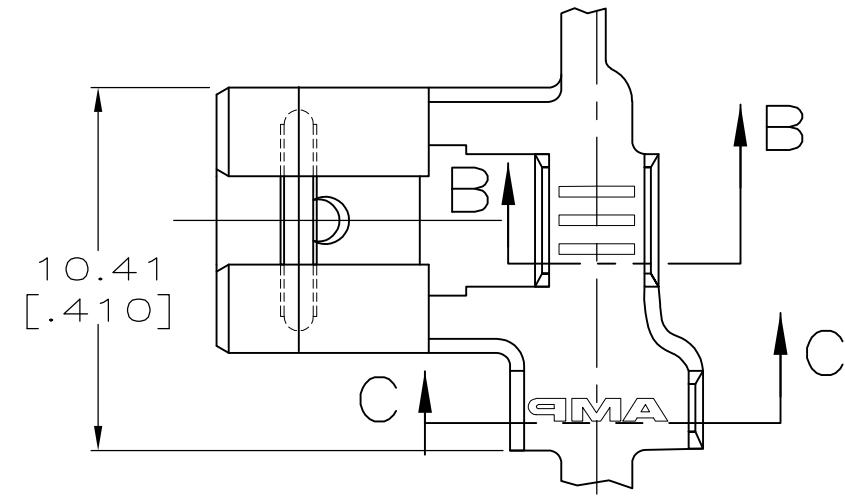
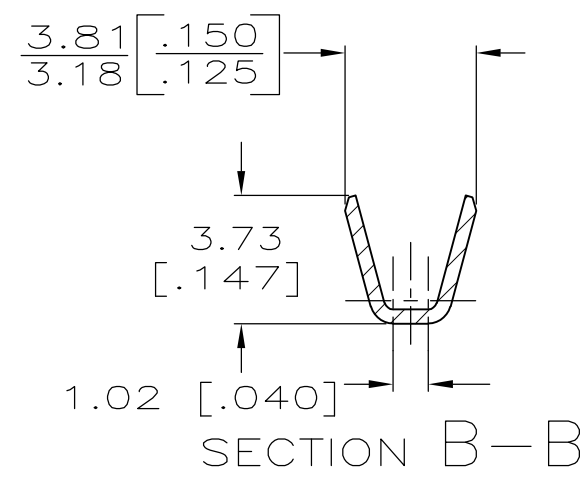
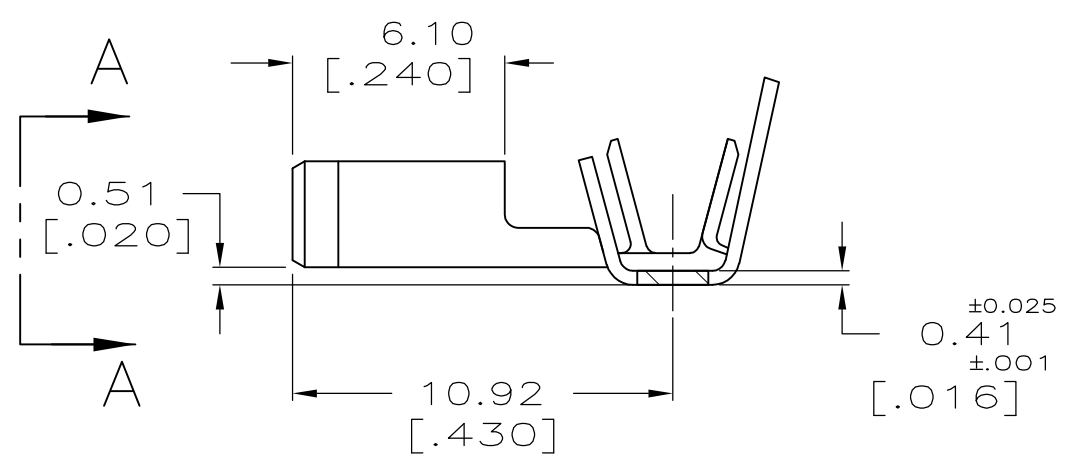

SECTION B-B

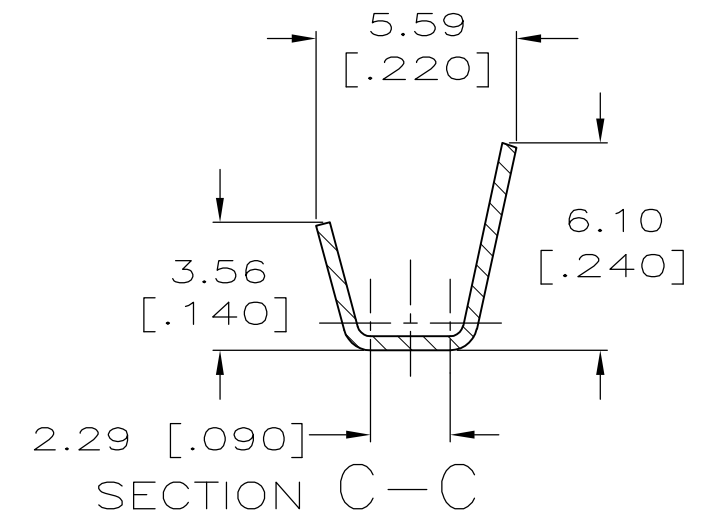

SECTION C-C

- 1 CONTINUOUS STRIP ON REELS.
- 2 MATING TAB THK IS 0.81±0.025 [.032±.001]
- 3 WIRE SIZE IS [#18-#14] AWG.
- 4 INSULATION RANGE IS 2.79-4.06 [.110-.160] DIA.
- 5 0.00381 [.000150] MIN TIN OVER 0.00254 [.000100] MIN COPPER.
- 6 PRELIMINARY - NOT FOR PRODUCTION

TIN OVER COPPER	5	6	63009-3
TIN			63009-2
-			63009-1
FINISH			PART NO

THIS DRAWING IS A CONTROLLED DOCUMENT.		DWN	JR RUTH	4/9/91	STE TE Connectivity												
DIMENSIONS: mm [INCHES]		CHK	MS FEHER	4/9/91													
TOLERANCES UNLESS OTHERWISE SPECIFIED:		APVD	C MEYERS	4/9/91													
<table border="0"> <tr><td>0 PLC</td><td>± -</td></tr> <tr><td>1 PLC</td><td>± -</td></tr> <tr><td>2 PLC</td><td>± -</td></tr> <tr><td>3 PLC</td><td>± 0.38 [.015]</td></tr> <tr><td>4 PLC</td><td>± -</td></tr> <tr><td>ANGLES</td><td>± -</td></tr> </table>		0 PLC	± -	1 PLC		± -	2 PLC	± -	3 PLC	± 0.38 [.015]	4 PLC	± -	ANGLES	± -	PRODUCT SPEC	-	NAME
0 PLC	± -																
1 PLC	± -																
2 PLC	± -																
3 PLC	± 0.38 [.015]																
4 PLC	± -																
ANGLES	± -																
MATERIAL	BRASS	FINISH	SEE TABLE	WEIGHT	-												
CUSTOMER DRAWING		SIZE	A3	CAGE CODE	00779												
SCALE		5:1	DRAWING NO	C-63009	RESTRICTED TO	-											
SHEET		1 of 1	REV	J1													