

AMP
AMP INCORPORATED
 HARRISBURG, PA 17105

AMP*
INSERTION/EXTRACTION TOOL KIT
91261-1

IS 6889

RELEASED
9-10-92

TOOLING ASSISTANCE 1 800 722-1111
 AMP FAX/PRODUCT INFO 1 800 522-6752

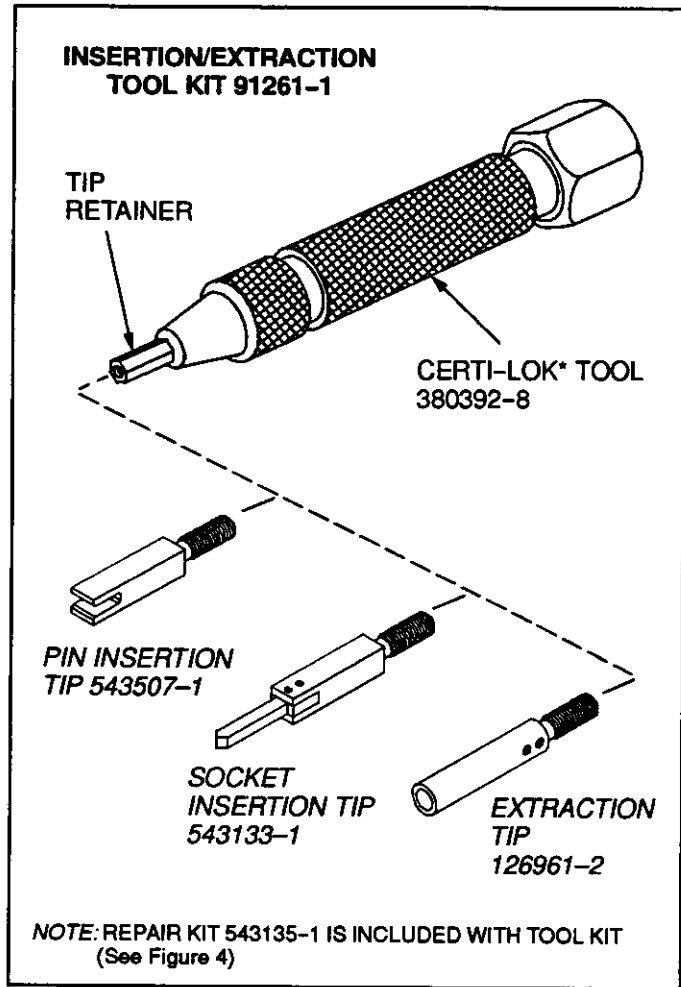

Fig. 1 cad, cad 9523

1. INTRODUCTION

AMP Insertion/Extraction Tool Kit 91261-1 includes the basic CERTI-LOK Tool with tip retainer, and interchangeable tips for contact insertion and extraction. The kit is used to replace ACTION PIN* contacts in AMPLIMITE*HDP-20 connectors mounted to printed circuit (pc) boards.

NOTE All dimensions on this document are in metric units [with U. S. customary units in brackets].

2. DESCRIPTION

Basic CERTI-LOK Tool 380392-8 is an impact tool featuring a spring-loaded handle and an internally-threaded tip retainer. The handle provides in-line force on the push tip assembly. The internal spring disengages automatically when the pre-set force is reached.

DANGER Do NOT depress the tool handle unless the tool is in its proper functional position. Personal injury and/or damage to the tool and components could result.

Kit 91261-1 includes Extraction Tip 126961-2, Insertion Tips 543133-1, 543507-1 and repair kit 543135-1 (Five inserts and two pins). The interchangeable tips feature external screw threads which fit into the internally-threaded tip retainer of the tool.

AMPLIMITE HDP-20 receptacle or plug connectors are pre-assembled with ACTION PIN contacts for mounting in pc boards. The correct replacement contact is selected from the chart in Figure 2.

<p>PIN 745633-5</p>	<p>2.36mm [.093] MINIMUM pcb MEDIUM PROFILE</p>
<p>SOCKET 1-745574-0</p>	<p>1.57mm [.062] MINIMUM pcb MEDIUM PROFILE</p>

Fig. 2 cad

CAUTION

Provide proper board support during contact insertion and extraction, taking care not to damage adjacent contacts, the connector assembly, or the pc board.

DANGER

Keep hands clear of ejection area to avoid personal injury.

3. EXTRACTION PROCEDURE (Figure 3)

To extract a socket contact from a mounted connector, proceed as follows:

1. Thread tip 126961-2, which has a shallow center indentation, into the tip retainer of the tool until tip is finger-tight.
2. Holding the tool perpendicular to the pc board, place the tip (indentation) over the post end of the ACTION PIN contact. Allow room for the contact to eject from the connector on the opposite side of the board.

3. Press the tool toward the board until a snapping action (spring release) occurs.
4. Using needle-nose pliers, carefully withdraw and remove the partially-ejected contact from the connector. If the contact does not pull free, repeat Steps 2 and 3.
5. Discard contact. Do NOT re-use contacts.

4. INSERTION PROCEDURES

Insertion procedures for contacts listed in Figure 2 require installation of tip 543507-1 or 543133-1 in the CERTI-LOK tool. Refer to Figure 3 and proceed as follows:

1. Position a new ACTION PIN contact in the AMPLIMITE connector and through the corresponding hole in the pc board.

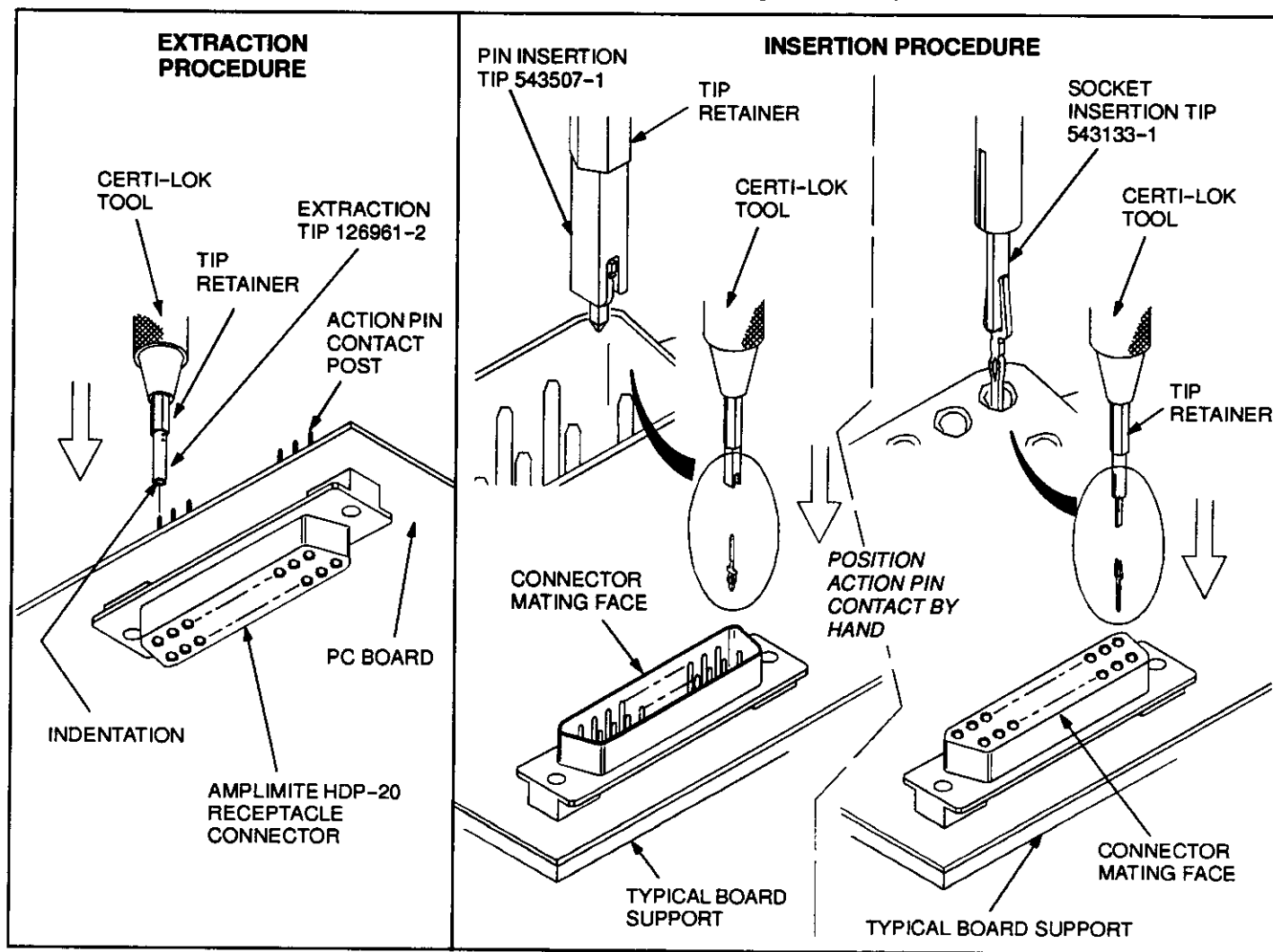

Fig. 3

cad

2. For socket contacts; place the tool tip into the socket contact as shown in Figure 3. For post contacts; place the tool tip over the post so post enters the hole in tool tip and the tip rests on shoulder of contact.

3. Keeping the tool perpendicular to the pc board, press the tool into the connector cavity until a snapping action (spring release) occurs. Repeat if needed until contact is fully seated.

4. Remove the tool, and inspect contact for proper insertion. Ensure that the mating end of the contact is BELOW the mating face of the connector or shoulder on post contact is flush with plastic surface of the plug connector, and that the length of the post end is consistent with adjacent posts.

tool release pressure is factory set at 71 - 80 N (Newton) [16 to 18 lb], and should NOT be adjusted by the customer.

Regular inspections of the tool and interchangeable tips should be performed by quality control personnel. A record of scheduled inspections should remain with the tool and/or be supplied to responsible supervisory personnel.

5. INSPECTION AND MAINTENANCE

Insertion/Extraction Tool Kit 91261-1 requires little maintenance other than to ensure that it is properly stored in a clean, dry area when not in use. The CERTI-LOK

6. TOOL/KIT PARTS

The parts listed in Figure 4 are customer-replaceable. A complete inventory can be stocked and controlled to prevent lost time when replacement of parts is necessary. Order replacement parts through your AMP representative, or call 1 800 526-5142, or send a facsimile of your purchase order to 1 717 986-7605, or write to:

CUSTOMER SERVICE (38-35)
AMP INCORPORATED
P. O. BOX 3608
HARRISBURG, PA 17105-3608

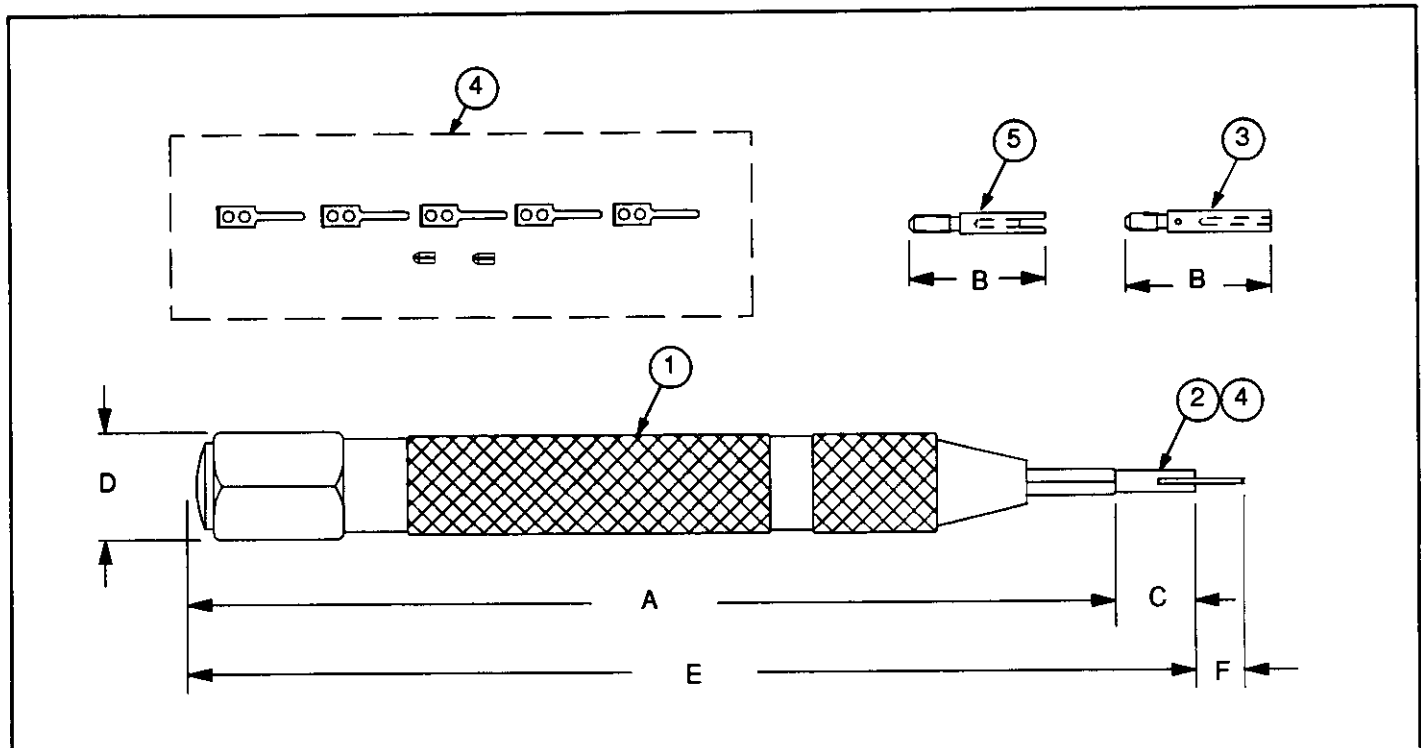

TOOL SPECIFICATIONS		KIT 91261-1 PARTS LIST				
DIMENSION mm [IN.]	WEIGHT	ITEM	PART NUMBER	DESCRIPTION	QTY	
A	137.16mm [5.5]	227 g [8 oz]	1	380392-8	TOOL, CERTI-LOK	1
B	21.59mm [.850]		2	543133-1	TIP, Insertion (Socket)	1
C	15.24mm [.6]		3	126961-2	TIP, Extraction	1
D	17.78mm [.700]		4	543135-1	KIT, Replacement Tip, Insertion (Includes Five Inserts and Two Pins)*	1
E	152.4mm [6.0]		5	543507-1	TIP, Insertion (Pin)	1
F	7.24mm [.285]					

* TO REPLACE INSERTION TIP: REMOVE TWO PINS, REPLACE WORN OR DAMAGED INSERT, AND REPLACE PINS.

cad

Fig. 4