

- 1
- 2
- 3
- 4
- 5
- 6
- 7
- 8
- 9
- 10
- 11
- 12
- 13
- 14
- 15
- 16
- 17
- 18

BASE

Polyamide based (PA) technopolymer with adjusting hexagon, black colour, matte finish.

STANDARD EXECUTION

Zinc-plated steel threaded stem with hexagon socket at the upper end. Base with screwdriver cross slot.

TECHNICAL DATA

It's the user's responsibility to determine whether the product is suitable for the intended purpose according to the actual conditions of use.

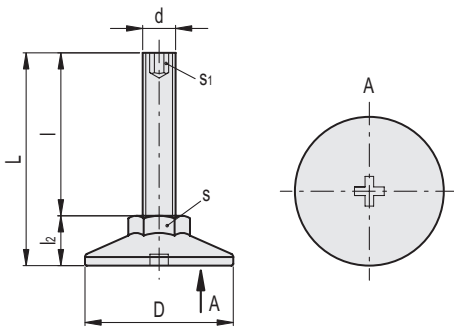

Conversion Table	
1 mm = 0.039 inch	
D	
mm	inch
25	0.98
30	1.18

METRIC

Code	Description	D	d	L	l	l2	s	s1	Max. limit static load* [N]	⚖️
431201	LX.25-SW13-M6x24-HS	25	M6	35	24	11	13	3	1500	8
431203	LX.25-SW13-M6x34-HS	25	M6	45	34	11	13	3	1500	10
431205	LX.25-SW13-M6x54-HS	25	M6	65	54	11	13	3	1500	14
431207	LX.25-SW13-M6x64-HS	25	M6	75	64	11	13	3	1500	16
431211	LX.25-SW13-M8x19-HS	25	M8	30	19	11	13	4	2500	10
431213	LX.25-SW13-M8x24-HS	25	M8	35	24	11	13	4	2500	12
431215	LX.25-SW13-M8x34-HS	25	M8	45	34	11	13	4	2500	14
431217	LX.25-SW13-M8x54-HS	25	M8	65	54	11	13	4	2500	18
431219	LX.25-SW13-M8x74-HS	25	M8	85	74	11	17	4	2500	22
431241	LX.30-SW17-M6x24-HS	30	M6	36	24	12	17	3	1500	14
431243	LX.30-SW17-M6x34-HS	30	M6	46	34	12	17	3	1500	16
431245	LX.30-SW17-M6x54-HS	30	M6	66	54	12	17	3	1500	20
431251	LX.30-SW17-M8x19-HS	30	M8	31	19	12	17	4	2500	17
431253	LX.30-SW17-M8x24-HS	30	M8	36	24	12	17	4	2500	18
431255	LX.30-SW17-M8x34-HS	30	M8	46	34	12	17	4	2500	20
431257	LX.30-SW17-M8x54-HS	30	M8	66	54	12	17	4	2500	24
431259	LX.30-SW17-M8x74-HS	30	M8	86	74	12	17	4	2500	28
431271	LX.30-SW17-M10x19-HS	30	M10	31	19	12	17	5	3000	21
431273	LX.30-SW17-M10x24-HS	30	M10	36	24	12	17	5	3000	22
431275	LX.30-SW17-M10x34-HS	30	M10	46	34	12	17	5	3000	24
431277	LX.30-SW17-M10x44-HS	30	M10	56	44	12	17	5	3000	26
431279	LX.30-SW17-M10x54-HS	30	M10	66	54	12	17	5	3000	28
431281	LX.30-SW17-M10x64-HS	30	M10	76	64	12	17	5	3000	30
431283	LX.30-SW17-M10x74-HS	30	M10	86	74	12	17	5	3000	32

* The max static load is the value above which the load applied to the element may cause some plastic material breakage, in particular conditions of use. Obviously, a factor that takes into consideration the importance and the safety level of the specific application must be applied to this value.

Levelling feet and supports

Conversion Table	
1 mm = 0.039 inch	
D	
mm	inch
40	1.57
50	1.97
60	3.15

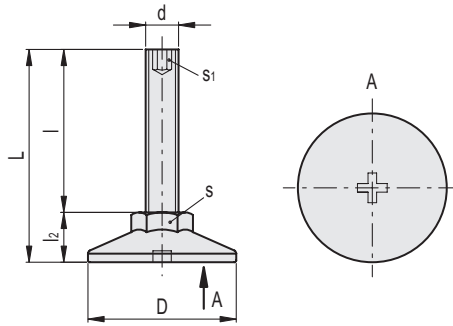

Code	Description	D	d	L	l	l2	s	s1	Max. limit static load* [N]	⚖️
431221	LX.40-SW17-M8x15-HS	40	M8	29.5	16	13.5	17	4	2500	20
431223	LX.40-SW17-M8x20-HS	40	M8	34.5	21	13.5	17	4	2500	22
431225	LX.40-SW17-M8x30-HS	40	M8	44.5	31	13.5	17	4	2500	24
431227	LX.40-SW17-M8x50-HS	40	M8	64.5	51	13.5	17	4	2500	26
431229	LX.40-SW17-M8x70-HS	40	M8	84.5	71	13.5	17	4	2500	29
431301	LX.40-SW17-M10x20-HS	40	M10	34.5	21	13.5	17	5	3000	24
431303	LX.40-SW17-M10x30-HS	40	M10	44.5	31	13.5	17	5	3000	26
431305	LX.40-SW17-M10x40-HS	40	M10	54.5	41	13.5	17	5	3000	28
431307	LX.40-SW17-M10x50-HS	40	M10	64.5	51	13.5	17	5	3000	31
431309	LX.40-SW17-M10x60-HS	40	M10	74.5	61	13.5	17	5	3000	34
431311	LX.40-SW17-M10x70-HS	40	M10	84.5	71	13.5	17	5	3000	37
431325	LX.40-SW17-M10x100-HS	40	M10	114.5	101	13.5	17	5	3000	46
431321	LX.40-SW17-M12x50-HS	40	M12	64.5	51	13.5	17	6	5000	34
431323	LX.40-SW17-M12x70-HS	40	M12	84.5	71	13.5	17	6	5000	40
431327	LX.40-SW17-M12x100-HS	40	M12	114.5	101	13.5	17	6	5000	50
431285	LX.50-SW19-M10x51-HS	50	M10	68	51	17	19	5	3000	64
431287	LX.50-SW19-M10x71-HS	50	M10	88	71	17	19	5	3000	68
431289	LX.50-SW19-M10x101-HS	50	M10	118	101	17	19	5	3000	75
431351	LX.50-SW19-M12x51-HS	50	M12	68	51	17	19	6	5000	67
431353	LX.50-SW19-M12x71-HS	50	M12	88	71	17	19	6	5000	72
431355	LX.50-SW19-M12x101-HS	50	M12	118	101	17	19	6	5000	79
431361	LX.60-SW24-M12x48-HS	60	M12	67	48	19	24	6	5000	67
431363	LX.60-SW24-M12x68-HS	60	M12	87	68	19	24	6	5000	73
431365	LX.60-SW24-M12x98-HS	60	M12	117	98	19	24	6	5000	82
431367	LX.60-SW24-M16x69-HS	60	M16	88	69	19	24	8	7500	102
431369	LX.60-SW24-M16x109-HS	60	M16	128	109	19	24	8	7500	132
431371	LX.60-SW24-M16x149-HS	60	M16	168	149	19	24	8	7500	156

* The max static load is the value above which the load applied to the element may cause some plastic material breakage, in particular conditions of use. Obviously, a factor that takes into consideration the importance and the safety level of the specific application must be applied to this value.

