

TNC 50 Ω

Right Angle Jack PCB
Solder Pin

56K201-400A5

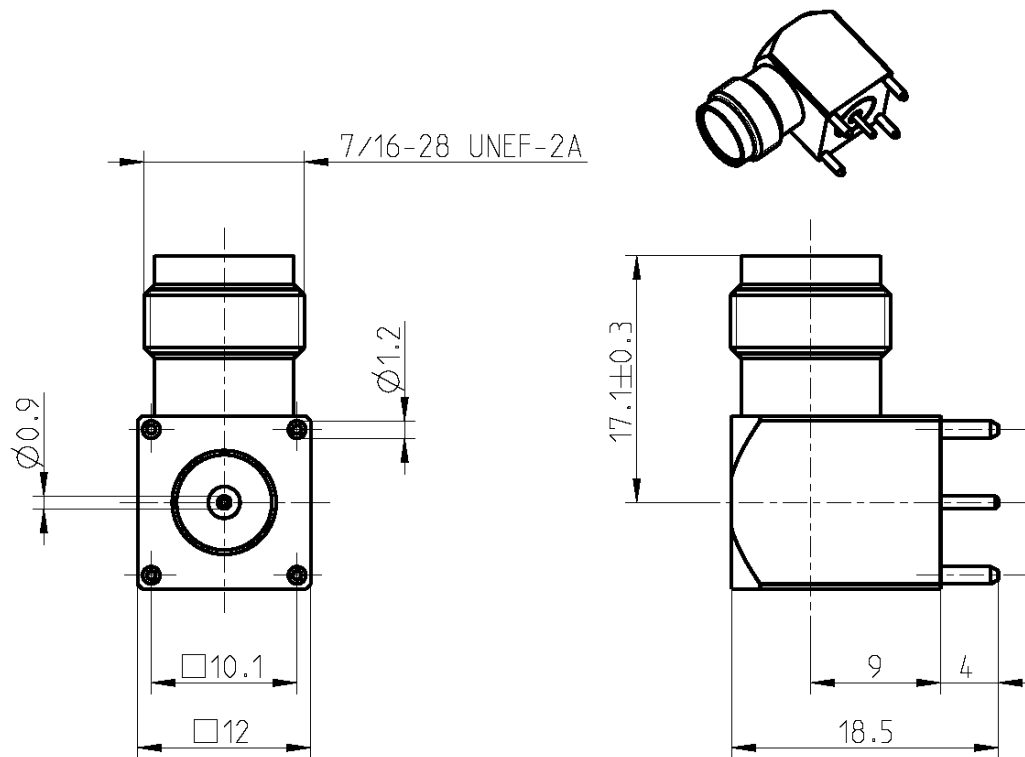

All dimensions are in mm; tolerances according to ISO 2768 m-H

Interface

According to IEC 60169-17, MIL-PRF-39012, DIN EN 122200

Documents

Panel piercing B 32

Material and plating

Connector parts

Center contact	CuBe
Outer contact	Brass
Body	Brass
Dielectric	PTFE

Plating

AuroDur®, gold plated
Nickel, 2.5-5 μm
Nickel, 2.5-5 μm

Dieses Dokument ist urheberrechtlich geschützt • This document is protected by copyright • Rosenberger Hochfrequenztechnik GmbH & Co. KG

RFB00035/12.20/6.4

Electrical data

Impedance	50 Ω
Frequency	DC to 10 GHz
Return loss	≥ 28 dB, DC to 1 GHz ≥ 22 dB, 1 to 2 GHz ≥ 20 dB, 2 to 4 GHz
Insertion loss	≤ 0.05 dB, DC to 4 GHz
Insulation resistance	≥ 5 GΩ
Center contact resistance	≤ 1.5 mΩ
Outer contact resistance	≤ 1 mΩ
Test voltage	1500 V rms
Working voltage	500 V rms
Power handling (at 20 °C, sea level, VSWR 1.0)	≤ 80 W @ 2 GHz

- VSWR in application depends decisive on PCB layout -

Mechanical data

Mating cycles	≥ 500
Center contact captivation: axial	≥ 15 N
Coupling test torque	≤ 1.7 Nm
Recommended torque	0.46 Nm to 0.69 Nm

Environmental data

Temperature range	-65 °C to +165 °C
Thermal shock	MIL-STD-202, Method 107, Condition B
Corrosion	MIL-STD-202, Method 101, Condition B
Vibration	MIL-STD-202, Method 204, Condition B
Shock	MIL-STD-202, Method 213, Condition G
Moisture resistance	MIL-STD-202, Method 106
Max. soldering temperature	IEC 61760-1, +260 °C for 10 sec.
RoHS	compliant

Tooling

N/A

Suitable cables

N/A

Weight

Weight 17.1 g/pce

While the information has been carefully compiled to the best of our knowledge, nothing is intended as representation or warranty on our part and no statement herein shall be construed as recommendation to infringe existing patents. In the effort to improve our products, we reserve the right to make changes judged to be necessary.

For the installation of the electrotechnical equipment, particular electrotechnical expertise is required.



Draft	Date	Approved	Date	Rev.	Engineering change number	Name	Date
Inge Mühlauer	10.08.04	Chr. Janßen	28.01.21	g00	20-1927	S. Huber-Siegl	28.01.21

Rosenberger Hochfrequenztechnik GmbH & Co. KG
P.O.Box 1260 D-84526 Tittmoning Germany
www.rosenberger.com

Tel. : +49 8684 18-0
Email : info@rosenberger.com

Page
2 / 2