

IS32LT3361 EVALUATION BOARD

DESCRIPTION

The IS32LT3361 is a continuous mode inductive step-down converter, designed for driving a single LED or multiple series connected LEDs efficiently from a voltage source higher than the LED voltage. The chip operates from an input supply between 6V and 40V and provides an externally adjustable output current of up to 1.3A.

The IS32LT3361 includes an integrated low-side output NMOS switch and a high-side output current sensing circuit, which uses an external resistor to set the nominal average output current.

Output current can be adjusted linearly by applying an external control signal to the ADJ pin. The ADJ pin will accept either a DC voltage or a PWM waveform. This will provide either a continuous or a gated output current. Applying a voltage less than 0.6V to the ADJ pin turns the output off and switches the chip into a low current standby state.

IS32LT3361 also features robust protections with fault reporting to ensure reliable operation.

The chip is assembled in a thermally enhanced SOP-8-EP package and operates over the temperature range of -40°C to +125°C.

EVALUATION BOARD PHOTO

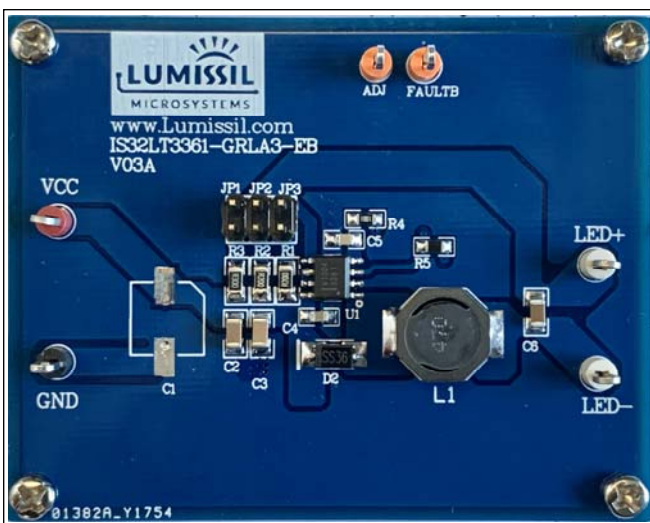

Figure 1 Photo of IS32LT3361 Evaluation Board

FEATURES

- Wide input voltage range: 6V~40V
- Integrated 40V NMOS switch
- Up to 1.3A output current
- High efficiency (up to 98%)
- Simple low parts count
- ±5% output current accuracy over -40°C to +125°C temperature
- Single pin on/off and brightness control using DC voltage or PWM
- Up to 2000: 1 dimming ratio at 100Hz PWM
- Up to 1MHz switching frequency
- Robust fault protections
 - ✓ Open drain shared fault reporting
 - ✓ LED string open/short protection
 - ✓ Integrated NMOS over current protection
 - ✓ Diode open/short protection
 - ✓ Thermal shutdown protection
- AEC-Q100 Qualified

RECOMMENDED EQUIPMENT

- 9~16V, 2A DC power supply
- LED load (2 LEDs in series/2A)
- Multi-meter

ABSOLUTE MAXIMUM RATINGS

- ≤ 40V power supply

Caution: Do not exceed the conditions listed above, otherwise the board will be damaged.

TEST PROCEDURE

The IS32LT3361 evaluation board is fully assembled and tested. Follow the steps listed below to verify board operation.

Caution: Do not turn on the power supply until all connections are completed.

- 1) Connect jumpers JP1, JP2 and JP3 on the board to select the output current.

JP1	JP2	JP3	R _S (Ω)	I _{OUT} (mA)
1	0	0	0.3	333
0	1	0	0.2	500
0	0	1	0.2	500
1	1	0	0.12	833
1	0	1	0.12	833
0	1	1	0.1	1000
1	1	1	0.075	1333

IS32LT3361 EVALUATION BOARD

- 2) Connect the positive terminal of the power supply to the VCC of the board and the negative terminal of the power supply to the GND of the board.
- 3) Connect the Cathode of the LED load to the LED- of the board. Connect the Anode of the LED load to the LED+ of the board.
- 4) To test PWM dimming, apply an external PWM signal to the ADJ of the board. If PWM dimming is not used, leave ADJ floating and the output PWM will be 100%.
- 5) To test analog dimming, apply an external 0.8~2.5V voltage signal to ADJ of the board. If analog dimming is not used, leave ADJ floating and the output will be 100%.
- 6) FAULTB is the fault reporting output, which is pulled up to VCC by R5 on board. It will be pulled low whenever a fault condition is detected. Please refer to table 3 for more details on fault conditions.

If not tested, leave FAULTB terminal floating.

Note 1: If connected to an MCU, please remove R5 and pull up by a 10KΩ resistor at the MCU side to avoid MCU damage due to high voltage on the VCC pin.

- 7) Turn on the power supply and the LED load will light up.
- 8) To measure the output current, please connect the current meter (multi-meter) in series with the LED load. No matter the power supply voltage or output LED load voltage are changed (in SPEC), the output current of the evaluation board will be always constant.

Note 2: if the LED load is fixed which means the output power is constant, the power supply current will change following the power supply voltage. The lower power supply voltage the higher power supply current. Please pay attention to the current limit of your power supply, especially at lower power supply voltage.

ORDERING INFORMATION

Part No.	Temperature Range	Package
IS32LT3361-GRLA3-EB	-40°C to +125°C (Automotive)	SOP8-EP, Lead-free

Table 1 Ordering Information

For pricing, delivery, and ordering information, please contact Lumissil's analog marketing team at analog@Lumissil.com or (408) 969-6600.

IS32LT3361 EVALUATION BOARD

OUTPUT CURRENT SETTING

The nominal average output current in the LED(s) is determined by the value of the external current sense resistor (R_S) connected between VIN and ISENSE pins and in is given by Equation (1):

$$I_{OUT_NOM} = \frac{0.1}{R_S} \quad (1)$$

Note that $R_S=0.077\Omega$ is the minimum allowed value for the sense resistor to maintain a switch current below the specified maximum value of 1.3A.

The Table 2 gives values of nominal average output current for several preferred values of current setting resistor (R_S) in the typical application circuit Figure 4:

Table 2 Output Current Setting

R_S (Ω)	Nominal Average Output Current (mA)
0.077	1300
0.15	667
0.3	333

The above values assume that the ADJ pin is floating and at a nominal voltage of $V_{REF} = 2.5V$.

R_S needs to be a 1% accuracy resistor with enough power tolerance and good temperature characteristic to ensure a stable output current. On PCB layout, this resistor MUST be placed as close to VIN and ISENSE pins as possible to avoid the EMI noise interference.

ENABLE AND PWM DIMMING

A high logic signal ($>2.5V$) on the ADJ pin will enable the IC. The buck converter ramps up the LED current to a target level which is set by current sense resistor, R_S .

When the ADJ pin goes from high to low ($<0.6V$), the buck converter will turn off, but the IC remains in standby mode for up to t_{SD} . When the ADJ pin goes high within this period, the LED current will turn on immediately. A Pulse-Width Modulated (PWM) signal with duty cycle D_{PWM} can be applied to the ADJ pin, as shown in Figure 2, to adjust the output current to a value below the nominal average value set by resistor R_S , the signal range is from 0V~5V. The logic "HIGH" must be higher than 2.5V, the logic "LOW" must be lower than 0.6V. The PWM signal must have the driving ability to drive the internal pull-up resistor R_{ADJ} (550k Ω typ.). A practical range for PWM dimming

frequency is between 100Hz and 20kHz.

There is an inherent PWM turn on delay time t_{PWM} (1.5 μs max.) during continuous PWM dimming. A high frequency PWM signal has a shorter period time that will degrade the PWM dimming linearity. Therefore, a low frequency PWM signal is good for achieving better dimming contrast ratio. At a 200Hz PWM frequency, the dimming duty cycle can be varied from 100% down to 1% or lower.

If the ADJ pin is kept low for over t_{SD} , the IC enters shutdown mode to reduce power consumption. The next high signal on ADJ will initialize a full startup sequence, which takes about 50 μs (Typ.). This startup sequence does not exist in a typical 100Hz to 20kHz PWM operation.

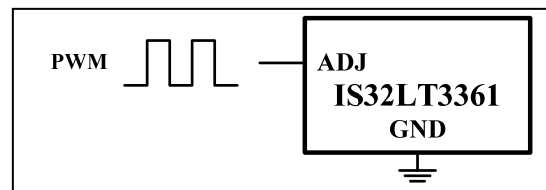

Figure 2 PWM Dimming Control Via ADJ Pin

ANALOG DIMMING

The ADJ pin can be driven by an external DC voltage within the range of 0.8V ~ 2.5V, as shown in Figure 3, to adjust the output current to a value below the nominal average value defined by R_S .

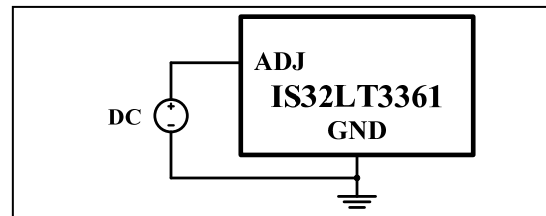

Figure 3 Dimming by External DC Voltage

The nominal average output current in this case is given by Equation (2):

$$I_{OUT_DC} = \frac{0.1V}{R_S} \times \frac{V_{ADJ} - 0.7V}{1.8V} \quad (2)$$

For $0.8V < V_{ADJ} < 2.5V$.

Note that 100% brightness setting corresponds to $V_{ADJ} = V_{REF} = 2.5V$. When driving the ADJ pin above 2.5V, the current will be clamped to 100% brightness automatically.

The input impedance of the ADJ pin is 550k Ω (Typ.).

IS32LT3361 EVALUATION BOARD

Table 3 Fault Actions

Fault Type	Detection Condition	Driver Action	Fault Reporting	Fault Recovering
LED open	$V_{IN} > V_{FT_UVLO}$ and NMOS switch on-time exceeds 20 μ s	Normal operation	FAULTB pin is pulled low after the delay time t_{FAULTB}	NMOS switch on-time is shorter than 20 μ s
Diode short	NMOS switch current exceeds I_{LX_LIMIT}	NMOS switch turns off immediately and retrys after every t_{SKIP} cycle time		NMOS switch current drops below I_{LX_LIMIT}
Diode open	LX pin voltage exceeds V_{OD_TH} for 1 switching cycles time	Latch at off state immediately		Power cycle
Thermal shutdown	The junction temperature exceeds 165°C	NMOS switch turns off immediately		The junction temperature falls below 150°C.

IS32LT3361 EVALUATION BOARD

SCHEMATIC

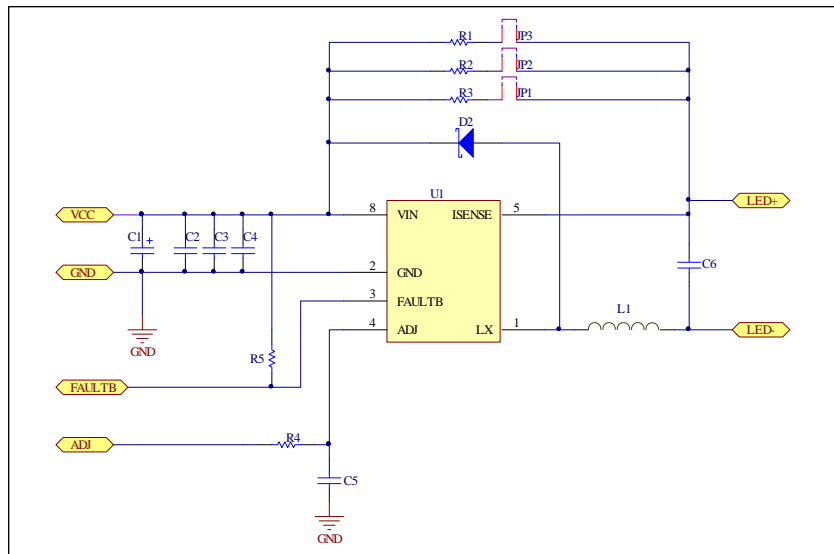

Figure 4 IS32LT3361 DEMO Schematic

Note 3: The Eval board do not include EMI filtering circuits. Using different external components, PCB layout, parameter setting may result in a significantly different EMI performance. Please fine tune EMI filtering circuit based on your actual EMI scan result.

BILL OF MATERIALS

Name	Symbol	Description	Qty	Supplier	Part No.
-	C1	NC			
PCB	-	70mm × 55mm, FR-4, 2 layers, 1oz copper	1	-	-
LED Driver	U1	Constant current LED driver	1	Lumissil Microsystems	IS32LT3361
Capacitor	C2,C3	CAP,10μF,50V,±10%,SMD	2	Yageo	AC1206KKX7R9BB106
Capacitor	C4	CAP,1μF,50V,±10%,SMD	1	Yageo	AC0805KKX7R9BB105
Capacitor	C5	CAP,2.2nF,50V,±10%,SMD	1	Yageo	AC0805KRX7R9BB222
Capacitor	C6	CAP,1μF,50V,±10%,SMD	1	Yageo	AC1206KKX7R9BB105
Resistor	R1,R2	RES,0.2R,1206,±1%,SMD	2	Yageo	AC1206JR-070R2L
Resistor	R3	RES,0.3R,1206,±1%,SMD	1	Yageo	AC1206JR-070R3L
Resistor	R4	RES,1k,0805,±5%,SMD	1	Yageo	AC0805FR-071KL
Resistor	R5	RES,10k,0805,±5%,SMD	1	Yageo	AC0805FR-0710KL
Diode	D1	3A,60V	1	DIODES	SS36
SMD Inductor	L1	47μH±20%,I _{SAT} ≥1.85A	1	Würth Elektronik	744066470

IS32LT3361 EVALUATION BOARD

PCB LAYOUT (SIZE: 70mm × 55mm, FR-4, 2 LAYERS, 1OZ COPPER)

Note 4: Since the PCB layout is very critical for the EMI performance, please follow this PCB layout's components placement and trace routing for better EMI performance. If need, please contact Lumissil to acquire the PCB layout files for your PCB layout reference.

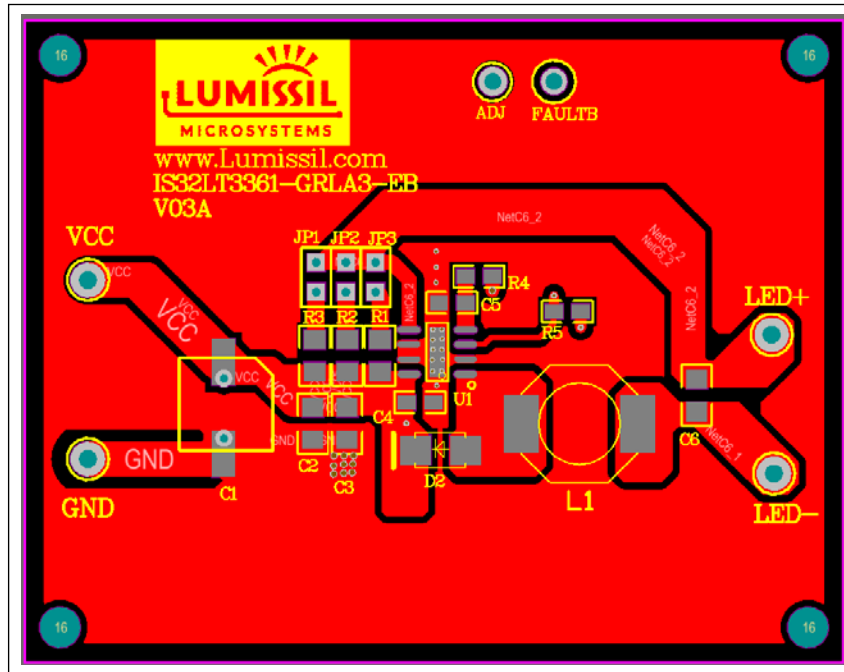

Figure 5 Board Top Layer

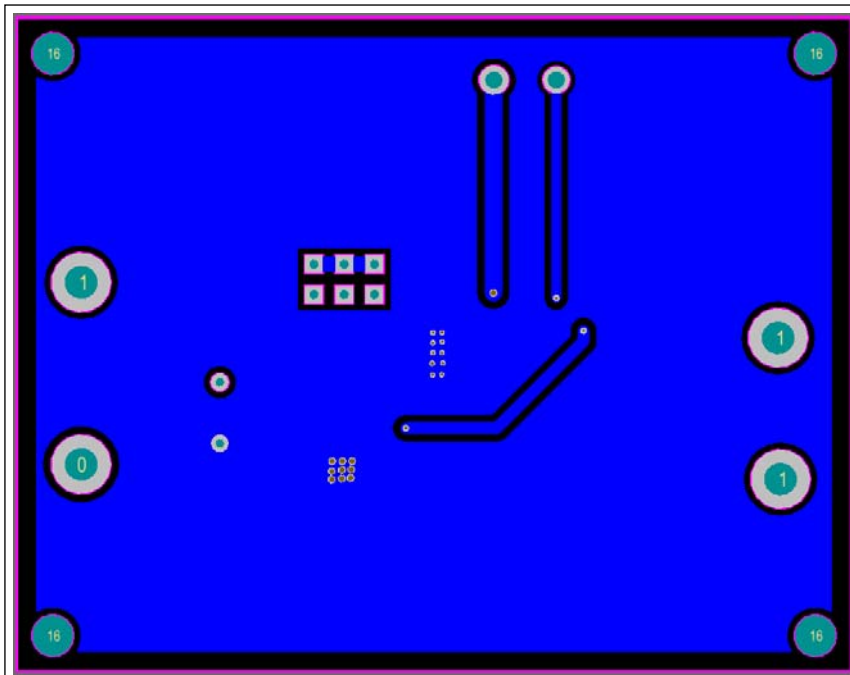

Figure 6 Board BOTTOM Layer

IS32LT3361 EVALUATION BOARD

REVISION HISTORY

Revision	Detail Information	Data
A	Initial release	2020.07.10

Copyright © 2020 Lumissil Microsystems. All rights reserved. Lumissil Microsystems reserves the right to make changes to this specification and its products at any time without notice. Lumissil Microsystems assumes no liability arising out of the application or use of any information, products or services described herein. Customers are advised to obtain the latest version of this device specification before relying on any published information and before placing orders for products.

Lumissil Microsystems does not recommend the use of any of its products in life support applications where the failure or malfunction of the product can reasonably be expected to cause failure of the life support system or to significantly affect its safety or effectiveness. Products are not authorized for use in such applications unless Lumissil Microsystems receives written assurance to its satisfaction, that:

- a.) the risk of injury or damage has been minimized;
- b.) the user assume all such risks; and
- c.) potential liability of Lumissil Microsystems is adequately protected under the circumstances