

Carrier_BT494030_SOT23-3_v

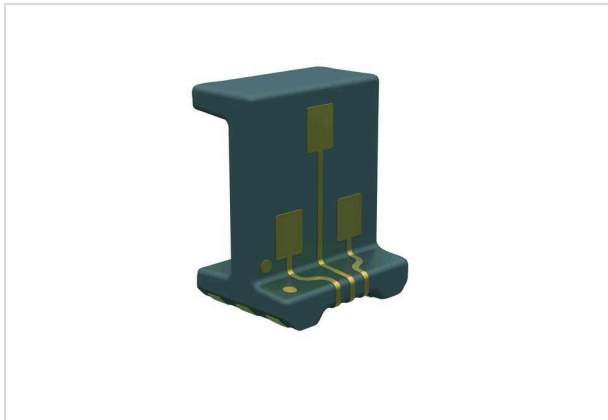

Image is for illustration purposes only. Please refer to product description.

Part number	78 01 030 0005
Specification	Carrier_BT494030_SOT23-3_v
HARTING eCatalogue	https://b2b.harting.com/78010300005

Identification

Category	Surface Mount Device
Series	3D-MID
Element	Carrier for electronic components
Specification	Interconnection
Features	Other materials or trace layouts on request!

Version

Fixing	PCB assembly (SMD)
Pack contents	Tape & reel 3400 pieces on reel Lower quantities available on request!

Technical characteristics

Operating temperature	-40 ... +125 °C
Storage temperature	-40 ... +125 °C

Material properties

Material	Liquid crystal polymer (LCP)
Surface (contacts)	Au ($\geq 0.05 \mu\text{m}$) over Ni ($\geq 4 \mu\text{m}$) over Cu (5...11 μm)
Length	4.9 mm
Width	4 mm
Height	3 mm

Commercial data

Packaging size	1,700
Country of origin	Switzerland
European customs tariff number	85340019
GTIN	5713140277410
eCl@ss	27469090 PCB connection technology (other, unspecified)

Other materials or trace layouts on request!



Drawing (dimensions in mm)

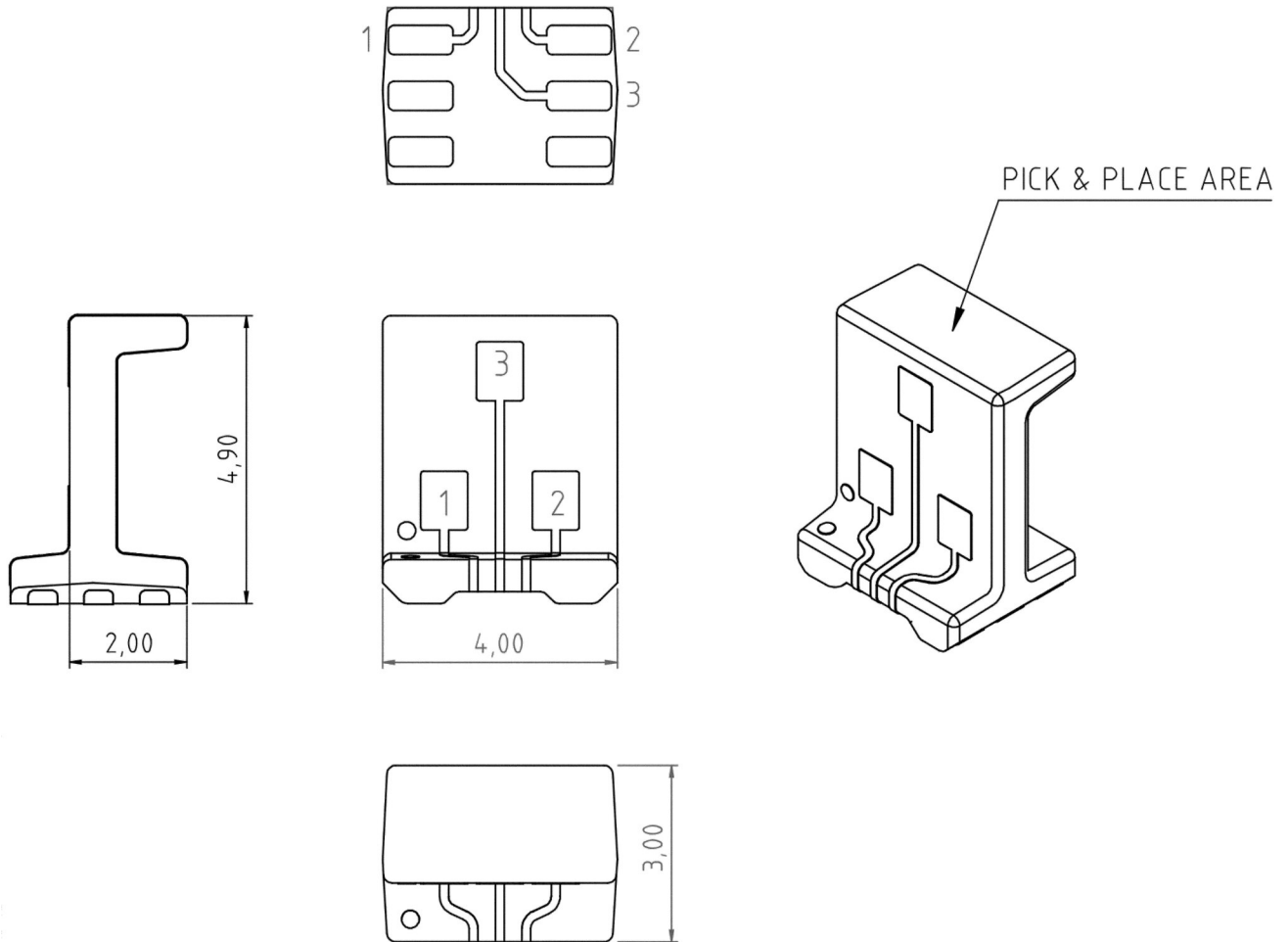

Drawing (dimensions in mm)

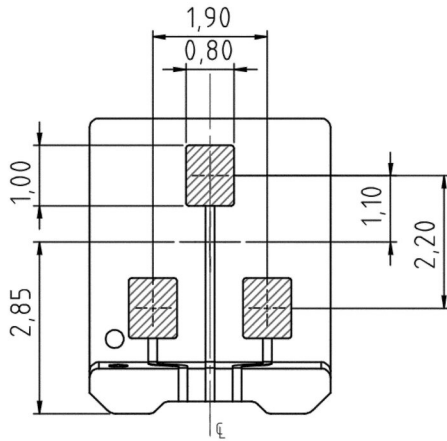

COMPONENT PADS LAYOUT
SOT23-3

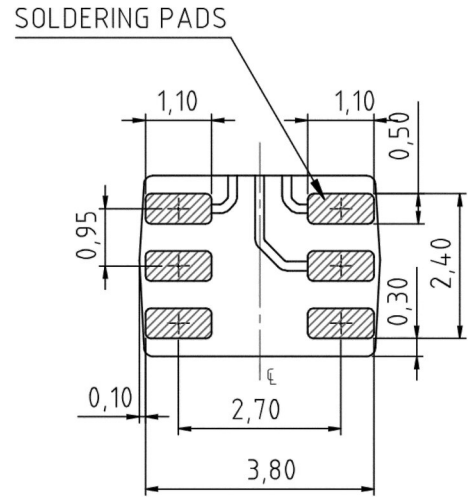

CARRIER PATTERN LAYOUT

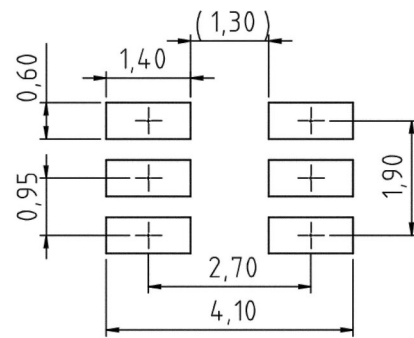
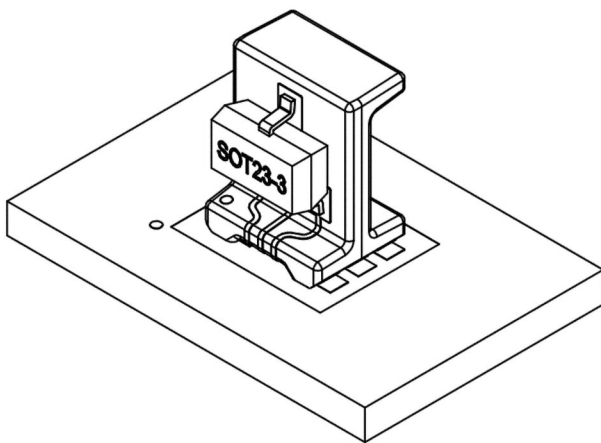

RECOMMENDED PCB PATTERN LAYOUT



Pushing Performance
 Since 1945

Soldering instructions

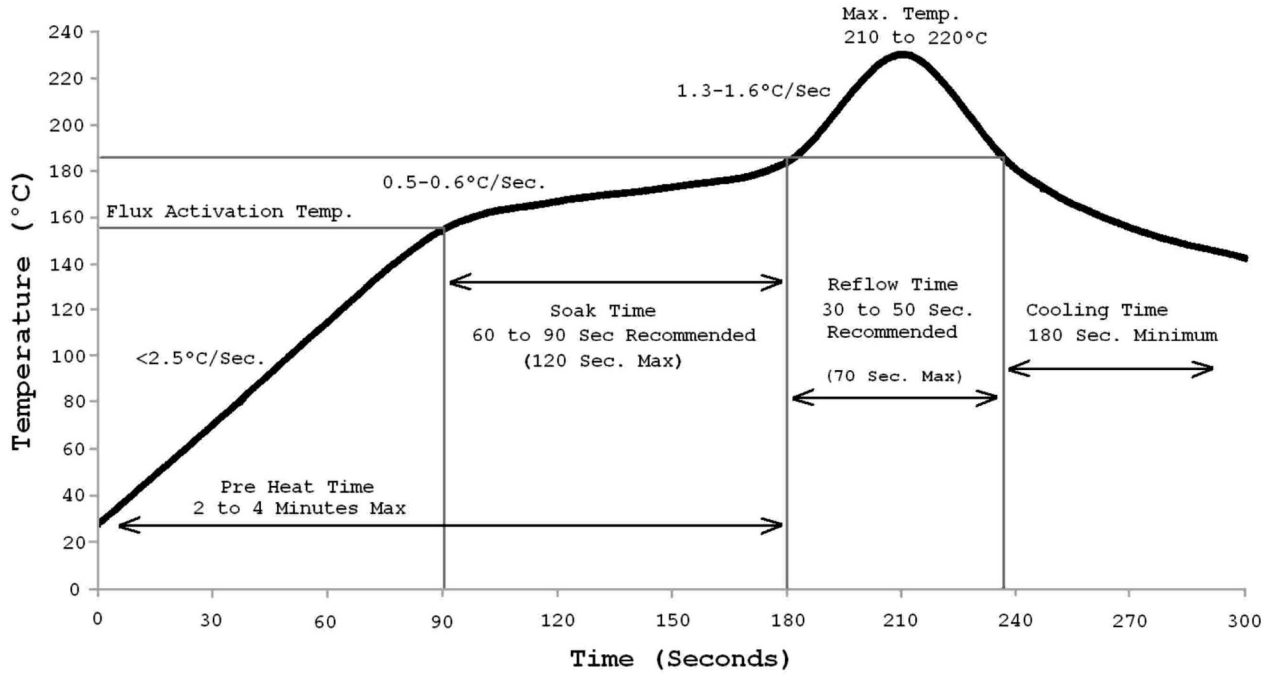

PB-free soldering profile
 (J-STD-020C)

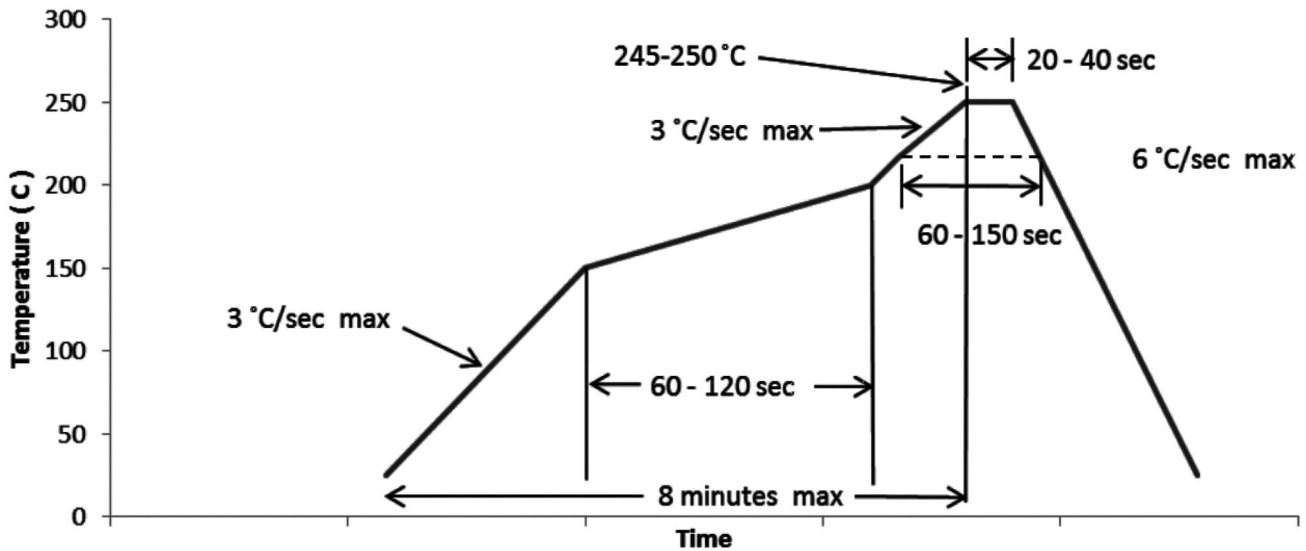



Tape layout & packaging

BT494030

MATERIAL	
PS Conductive Black	
surface resistance $10^3 \Omega$ - $10^5 \Omega$	

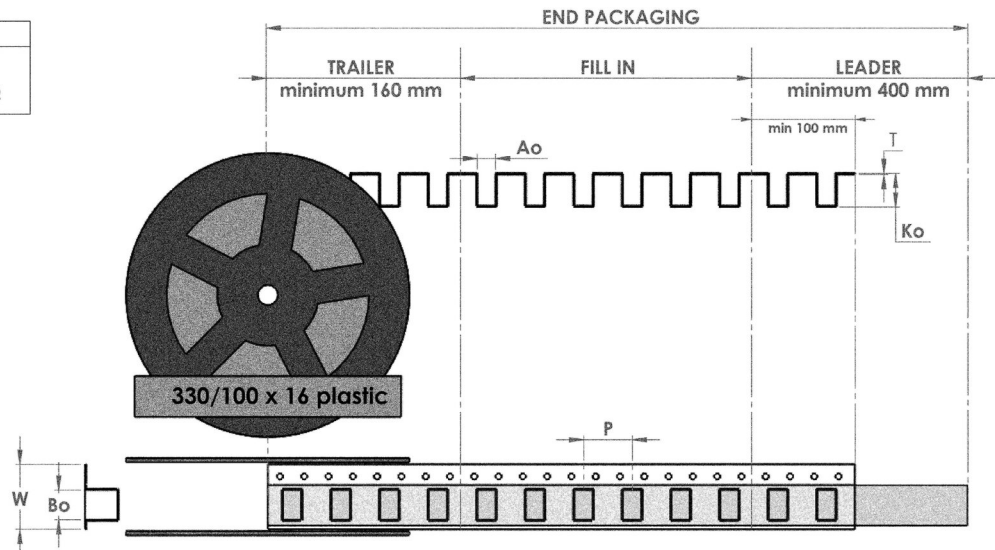
DIMENSIONS	
W	= 16 mm
P	= 8 mm
T	= 0,4 mm
Ao	= 3,3 mm
Bo	= 4,3 mm
Ko	= 5,2 mm
TRAILER 20 cvt	
FILL IN 1700 pcs	
LEADER 50 cvt	

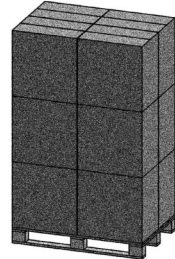

PACKING						
		REEL		BOX		PALLET
LENGTH		42 m		630m		7560 m
CAVITIES		5250 cvt		78750 cvt		945000 cvt
PARTS		3400 pcs[2x1700]		51000 pcs		612000 pcs
WEIGHT		0,63kg		10,71 kg		143,5 kg
QTY		Single Reel		15 reels/box		12 boxes/pallet
DIMENSION		560/76 x 16 cardboard		39 x 58 x 58 [cm]		80 x 120 x 190 [cm]