



MAGNASPHERE L2X-800 INSTALLATION INSTRUCTIONS: All Models of (L2X) 800-Series [Page:1]

CAUTION: MAGNASPHERE MAGNET MODULES AND ANTI-REMOVAL MAGNETS ARE EXTREMELY POWERFUL: TAKE PRECAUTIONS TO AVOID THE MAGNETIC ATTRACTION OF SHARP TOOLS AND TO AVOID INJURY FROM THE PINCHING FORCE BETWEEN THE MAGNET AND FERROUS METALS OR OTHER MAGNETS.

Attention: modules à aimants Magnasphere et anti-enlèvement aimants sont très puissants: prendre des précautions pour éviter l'attraction magnétique d'outils tranchants et à éviter les blessures de la force de pincement entre l'aimant et les métaux ferreux ou d'autres aimants.

Required Tools and Components

Provided by Manufacturer (per module set)

- 1 L2X switch module
- 1 L2X magnet module
- 7 switch & magnet module self-tapping screws (#10-32 x 2")
- 1 self-tapping screw (#6, 1" long)
- 2 1/16" plastic spacer plates
- 1 Removal-Tamper magnet
- 2 Removal-Tamper caps
- 1 1/2" NPT Plug

(P/N: SP062)

Provided by Installer

- Intrinsically Safe Barrier (Listed to at least the Hazardous Location Class)
- Power drill
- Drills bits: #35, #21
- Phillips screwdriver or a Phillips bit for use in the drill/bit-driver
- Rule (or any linear measuring instrument)
- A center punch (& hammer) for more accurate hole locations may be used
- A pilot drill bit for screws (3/32" or smaller) may be used
- Additional 1/16" SPACERS (10/ BAG – MAGNASPHERE P/N SP062)
- Adjustable wrench
- Pipe wrench
- Thread Locking Compound or a lockable N.P.T plug (see p.2 #3, note)
- Rigid 1/2" NPT Conduit (18" Min. per UL634 Level 2 Standard)

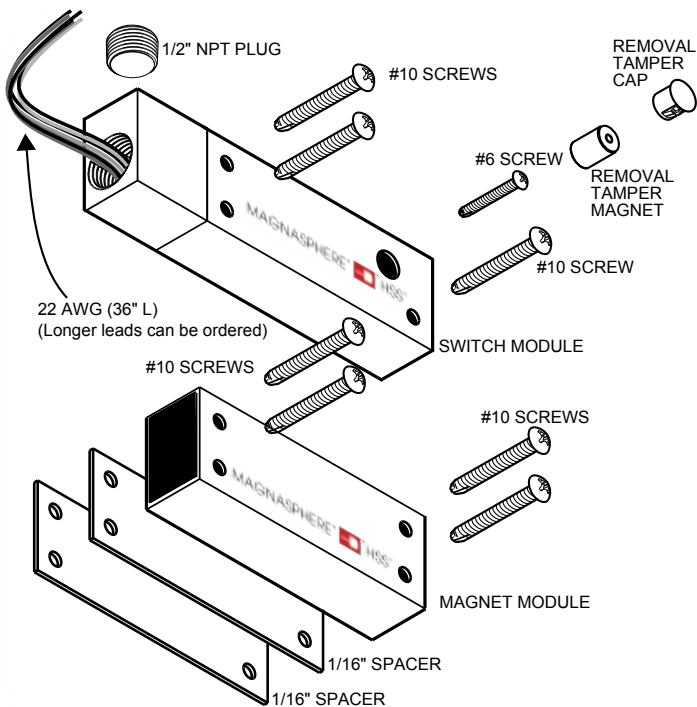

Specifications

Max Current: 0.25 A Resistive

Max Voltage: 30 VDC

Max Power: .25 W Resistive

Suitable for outdoor use.

The Magnasphere HSS Level 2 series is intended to be connected to a UL Listed compatible control panel for US applications and a ULC Listed compatible control panel for Canadian applications.

Resistors are Optional

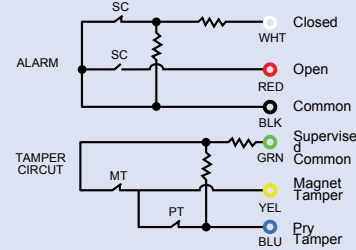

L2S Series

Test the Magnet-Tamper circuit here with a powerful magnet

Remove to test the Pry Tamper circuit

Resistors are Optional

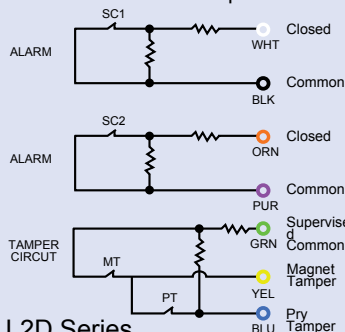

L2D Series

Installation Plan

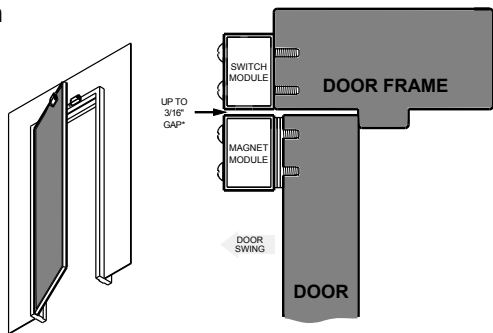

Plan to mount the switch module to the door frame, close to the door/frame gap and without door-swing interference. The magnet module should be mounted directly below the switch. Spacers may be used to attain sufficient alignment of the modules. Recommended placement for the set is 8 inches from the latch side of the door, at the top. The operating gap must not exceed 3/16". Provided templates may assist locating holes. ***A gap up to 1/8" is required for compliance with UL634 Level 2 high security standard.**

Mark & pilot-drill all hole locations. Drill the 3 mounting hole locations for the #10 screw (#21 bit). **Drill the Removal-Tamper screw location for the #6 screw (#35 bit).** Hold the switch module in position: Drive each screw in until seated, securing the device.

CAUTION: Magnasphere's magnet module and anti-removal magnet are extremely powerful: Take precautions to avoid the magnetic attraction between the magnet and ferrous metals (or other magnets). Align the magnet module directly below the switch module. Determine whether spacers are needed to achieve mounted alignment of the modules. Hold the magnet module and any spacers in position and drill the 4 hole locations for #10 screws (#21 bit). Drive each screw in until seated, securing the device. Insert the Removal-Tamper magnet and then the Removal-Tamper plug into the 3/8" hole at the face of the switch module. Check that the gap between modules is no greater than 1/8". The mechanical installation of the set is complete.

Wrench Note

Recommended: Pre-Fasten an 1/2" NPT conduit section to the Switch Module in order to prevent excessive stress.

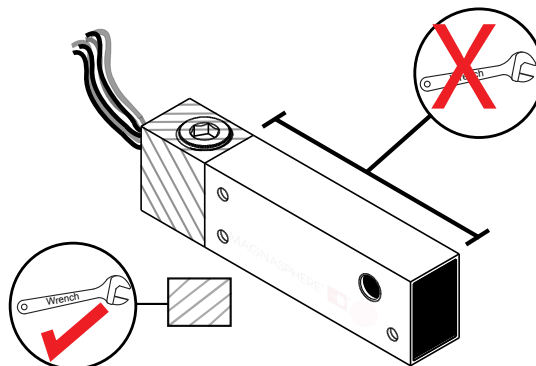

Additional mounting hardware, resistor configurations, cable lengths, and other variants are available.

Patents: #5977873, #6506987, #6803845, #7291794, #7944334, #8314698, #6087936, #6603378, #7023308, #RE39731, #8228191, #8648720 & Other Patents Pending

MAGNASPHERE

MAGNASPHERE N22 W22931 Nancys Ct. Ste 3, Waukesha, WI 53186 tel 262.347.0711 fax 262.347.0710 www.magnasphere.com

Installation Note #1

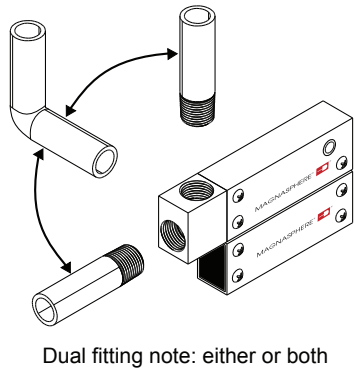

Dual fitting note: either or both

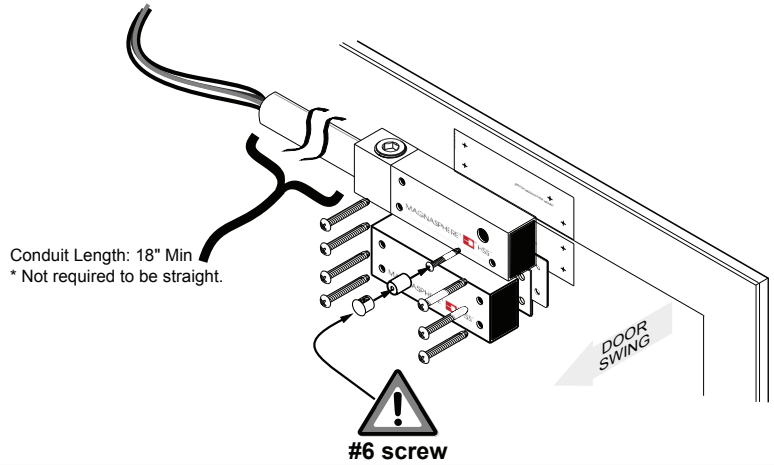

Installation Note #2

Note for out-swinging (egress) door:
An adapting bracket may be necessary to accommodate egress door installations.

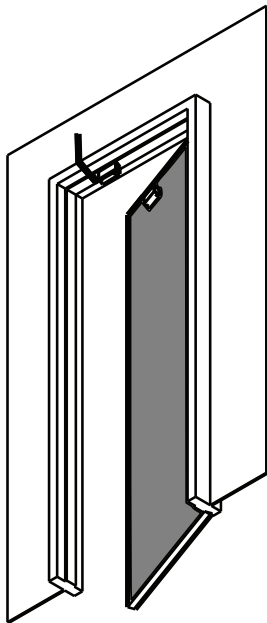

Installation Notes (#3, #4, #5, #6, #7)

#3 Dual NPT Fitting

Once lead-wire routing is determined, install enclosed NPT plug in the remaining hole. The use of a thread locking compound (e.g. Loctite® Threadlocker Red 271™) is recommended for securing the plug permanently.

Note: The enclosed NPT plug must be installed in the remaining hole (unless both NPT ports are used by conduit). Alternatively, a security NPT locking plug may be used for non-permanent closure of the port (used by utility companies, manufacturers include: Highfield and Inner-Tite).

#4 Wire Twisting Note

For installations where the switch module must be spun, wrenched on to a stationary conduit and the lead-ends cannot freely rotate within the conduit: Counter-rotate the leads before threading the switch module to the conduit. Approximately six revolutions from the start of thread should allow the fitting to be tightened. **FAILURE TO PROTECT THE LEADS FROM TENSION OR TWIST CAN CAUSE FATAL DAMAGE TO THE SWITCH MODULE.**

#5 Intrinsic Safety Barrier must be installed in order to meet Intrinsic Safety Requirements

#6 Refer to figure 1-1 for completed installation.

#7 Magnasphere L2X Series is a Simple Apparatus; when used with an Intrinsic safety Barrier, will meet or exceed the requirements for certain hazardous locations.

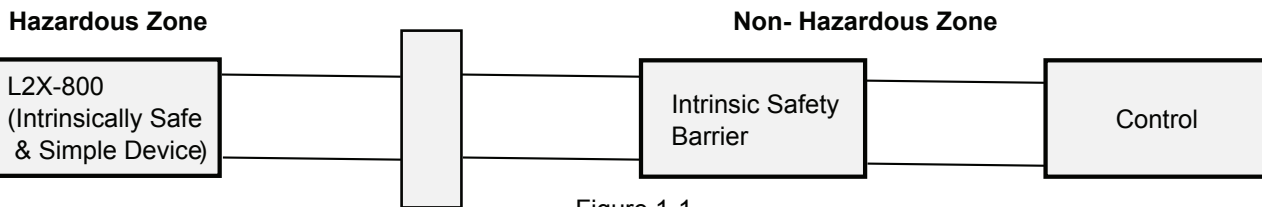

Figure 1-1

Note: Explosion Proof and Intrinsic Safety are two Independent means to satisfy the Division of Hazardous Locations

Key Technical Terms

Explosion Proof

"Explosion proof Apparatus: Apparatus enclosed in a case that is capable of withstanding an explosion of specified gas or vapor that may occur within it and of preventing the ignition of a specified gas or vapor surrounding the enclosure by sparks, flashes or explosion of the gas or vapor within, and that a surrounding flammable atmosphere will not be ignited thereby. "

vs.

Intrinsically Safe

"Intrinsically Safe System: An assembly of interconnected intrinsically safe apparatus, associated apparatus, and interconnecting cables, in that those parts of the system that may be used in hazardous(classified) locations are intrinsically safe circuits."

Source: Class I Division 1 (UL Standard pertaining Flammable gases, vapors or liquids)