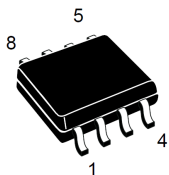

## Intelligent power switch

**SO-8**

### Features

- 0.5 A output current
- Low-side or high-side switch configuration
- Supply voltage range from 6 V to 48 V
- Overload and short-circuit protections
- Internal voltage clamping
- Supply and output reversal protection
- Thermal shutdown
- GND and  $V_S$  open wire protection
- Adjustable delay at switch-on
- Indicator status LED driver
- +5 V regulated AUX voltage
- High burst immunity

### Application

- Industrial PC peripheral input/output
- Numerical control machines

### Description

The TDE1707BFP and TDE1707CFP are 0.5 A integrated power switches with up to 48 V power supply capability. Two output configurations are possible. The former is the load to GND (high-side mode) and the latter is the load to  $V_S$  (low-side mode). This device is dedicated to proximity detectors; its internal +5 V supply can be used to supply external circuits (please refer to AN495 and AN1213 on [www.st.com](http://www.st.com)). A signal is internally generated to block the IN signal, and prevent the output switch, as long as an abnormal condition is detected. The power-on transition, as well as the chip overtemperature and the output overcurrent, generate this signal. A minimum delay of 25  $\mu$ s (typ. value) is added to the trailing edge of this signal to ensure that a stable normal situation is present when the signal disappears. The delay (the disappearance of block signal) can be further increased by connecting a capacitor between pin 3 and ground. It can drive resistive or inductive loads.

#### Product status link

[TDE1707](#)

#### Product label



# 1 Block diagram

Figure 1. Block diagram

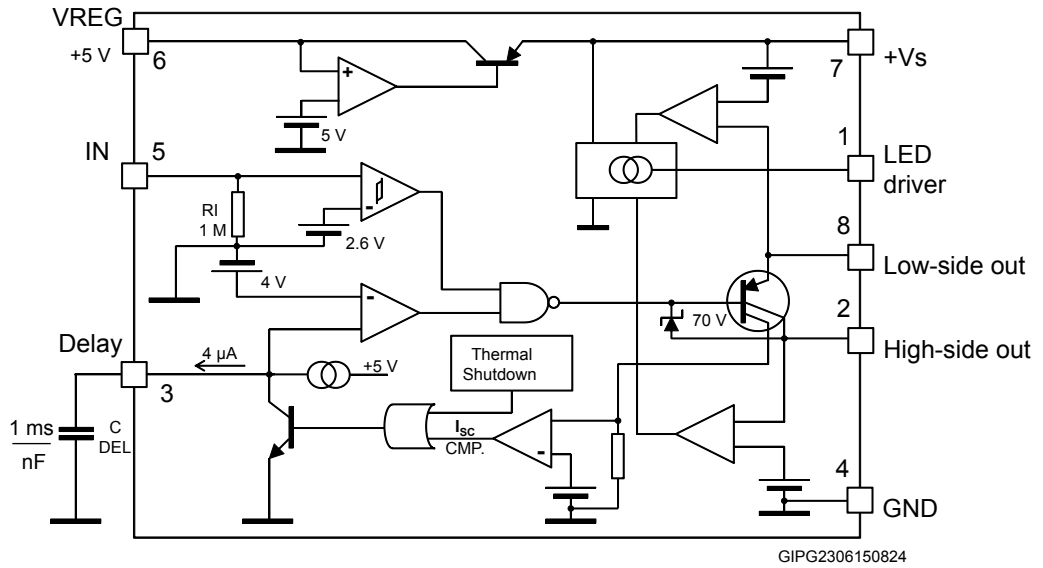

## 2 Pin configuration

**Figure 2. Pin connections (top view)**

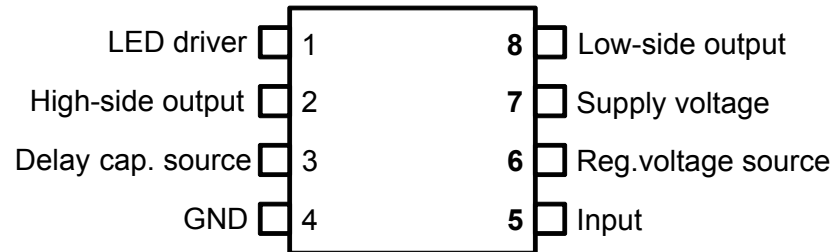

GIPG230615900LM

**Table 1. Pin description**

Pin	Function
1	LED driver
2	High-side output
3	Delay cap. source
4	GND
5	Input
6	Regulator voltage source
7	Supply voltage
8	Low-side output

### 3 Maximum ratings

**Table 2. Absolute maximum ratings**

Symbol	Parameter	Value	Unit
V <sub>S</sub>	Supply voltage	50	V
	Supply reverse voltage	50	V
I <sub>O</sub>	Output current	Internally limited	mA
V <sub>REG</sub>	Regulated pin voltage	0 to 7	V
V <sub>delay</sub>	Delay cap. source pin	0 to 5	V
V <sub>O</sub>	Output voltage	55	V
V <sub>IN</sub>	Input voltage	-10 to 50	V
T <sub>STG</sub>	Storage temperature range	-55 to 150	°C
T <sub>J</sub>	Operating junction temperature range	-25 to 85	°C
P <sub>tot</sub>	Power dissipation	Internally limited	W
E <sub>i</sub>	Energy inductive load	150	mJ

**Table 3. Thermal data**

Symbol	Parameter	Value (TDE1707BFP)	Value (TDE1707CFP)	Unit
R <sub>th(JC)</sub>	Thermal resistance junction-case	15	15	°C/W
R <sub>th(JA)</sub>	Thermal resistance junction-ambient	150	130	

## 4 Electrical characteristics

$V_S = 24\text{ V}$ ,  $T_J = -25\text{ to }+85\text{ °C}$  unless otherwise stated

**Table 4. Electrical characteristics**

Symbol	Parameter	Test conditions	Min.	Typ.	Max.	Unit
$V_S$ 7	Supply voltage		6		48	V
$I_{SR}$ 7	Supply reverse current	$V_{SR} = -48\text{ V}$			1.5	mA
$I_q$ 7	Quiescent current	$I_{REG} = I_{LED} = 0\text{ mA}$ ; $V_I < 2\text{ V}$ ; $V_S = 6\text{ V to }48\text{ V}$			1.5	mA
$I_O$ 8/2	Output current	$V_S = 6\text{ V to }32\text{ V}$			500	mA
		$V_S = 32\text{ V to }48\text{ V}$			300	mA
$V_{SAT}$ 8/2	Output voltage drop <sub>8-2</sub>	$I_O = 500\text{ mA}$		1.1	1.6	V
		$I_O = 300\text{ mA}$			1.5	V
$I_{SC}$ 8/2	Short-circuit current		0.7		1.5	A
$V_{CL}$ 8/2	Internal voltage clamp	$I_{CL} = 10\text{ mA}$	55		70	V
$I_{OLK}$ 8/2	Output leakage	$V_I < 2\text{ V}$ ; $V_O = 0\text{ to }V_S$ (Pin 2)		100	300	$\mu\text{A}$
		$V_I < 2\text{ V}$ ; $V_O = 0\text{ to }V_S$ (Pin 8)			100	
$V_{ith}$ 5	Input voltage threshold		2		3	V
$V_{ihys}$ 5	Input threshold hysteresis			300		mV
$I_{lk}$ 5	Input current	$V_I = 5\text{ V}$		2	5	$\mu\text{A}$
$V_{REG}$ 6	Regulated output voltage	$I_{REG} < 5\text{ mA}$	4.5	5	5.5	V
$I_{scr}$ 6	Short-circuit regulated		6	30	50	mA
$I_{REG}$ 6	Output regulator current	$V_S = 35\text{ V}$			6	mA
		$V_S = 48\text{ V}$			4	mA
$I_{OLD}$ 1	Current source sink LED driver	Output ON ( $\pm$ )	2	3	4	mA
$V_{OLD}$ 1	Voltage drop LED driver	$I_{OS} = 2\text{ mA}$ ( $\pm$ )		1.2	1.6	V
$O_{ldlk}$ 1	LED driver off leakage	$V_I < 2\text{ V}$ ; $R_L < 1\text{ k}\Omega$			10	$\mu\text{A}$
$I_{dch}$ 3	Delay cap. charge current	$T_J = 25\text{ °C}$	2	4	6	$\mu\text{A}$
$V_{dth}$ 3	Delay voltage trigger	$T_J = 25\text{ °C}$		4		V

## 5 Application information

The LED driver reports the output status. It can source or sink current ( $I_{OL\text{D}}$  typ. = 3 mA), according to the output configuration chosen. The thresholds, represented by the output comparator in the block diagram, are set from 1.5 V to 2 V. For instance, in high-side load case of the application circuit, when the voltage on pin 8 differs from  $V_{CC}$  less than 1.5 V, the output is sensed in "OFF" state and the LED driver is disabled. If instead pin 8 differs from  $V_{CC}$  more than 3 V (the output comparator threshold value plus the drop voltage on the LED), then the output is sensed "ON" and the driver forces the current on the LED.

Table 5. Dynamic characteristics

Symbol	Parameter	Test conditions	Min.	Typ.	Max.	Unit
$t_{on}$	Propagation turn-on time	$V_I = 0$ to 5 V		15		$\mu\text{s}$
$t_{off}$	Propagation turn-off time	$V_I = 5$ to 0 V		15		$\mu\text{s}$
$t_{don}$	Delayed turn-on time / nF delay capacitor		0.65	1	2	ms
$t_{dmin}$	Minimum delayed $t_{on}$ , delay capacitor = 0			25		$\mu\text{s}$

Figure 3. Application circuit

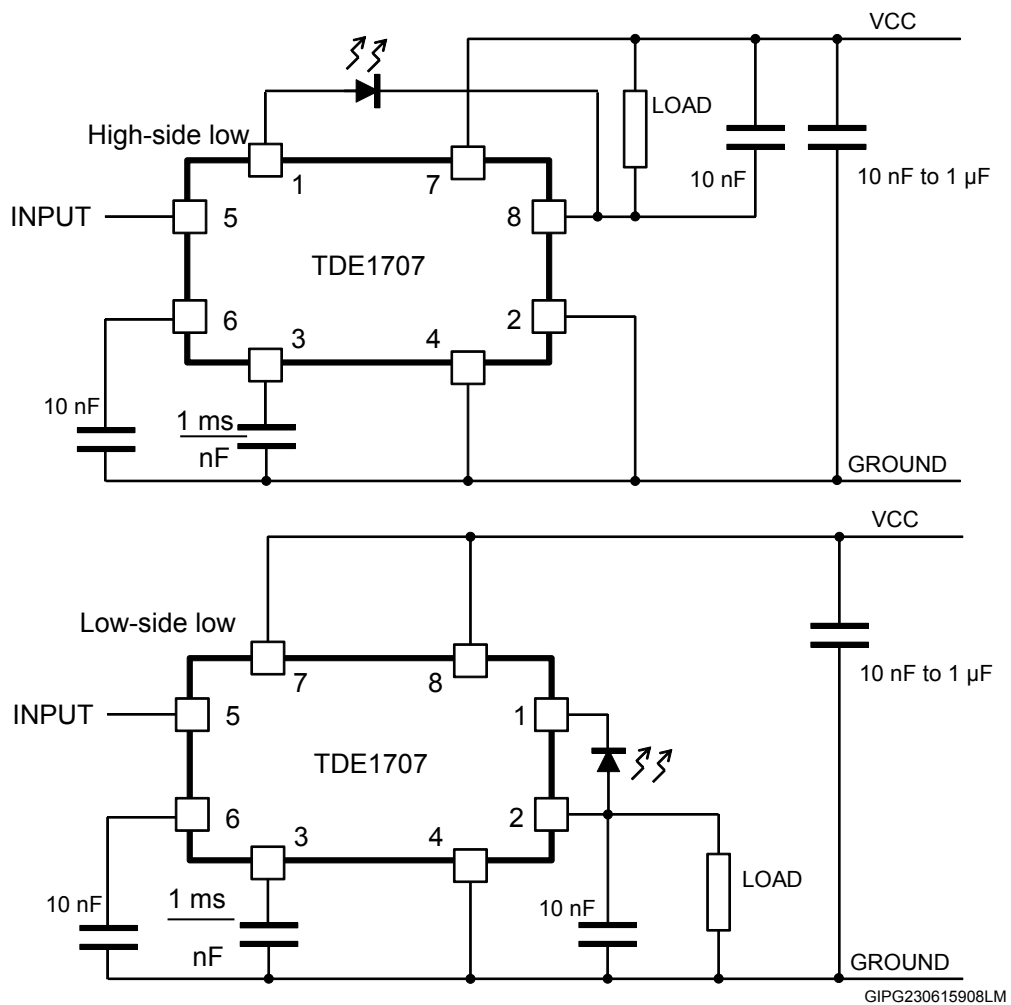

GIPG230615908LM

## 6 Thermal behavior

**Figure 4. Input threshold voltage vs. temperature ( $V_S = 24\text{ V}$ )**

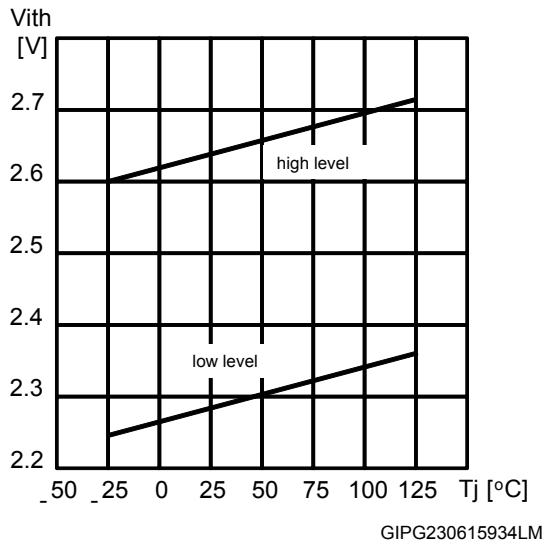

**Figure 5. Saturation voltage vs. temperature ( $V_S = 24\text{ V}$ ;  $I_O = 500\text{ mA}$ )**

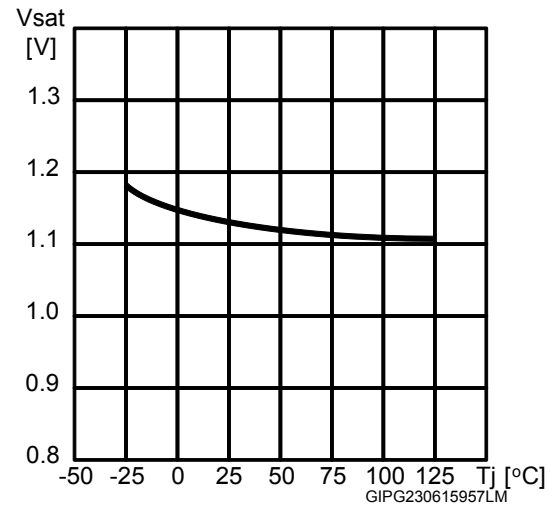

**Figure 6. Quiescent current vs. temperature ( $V_S=24\text{ V}$ )**

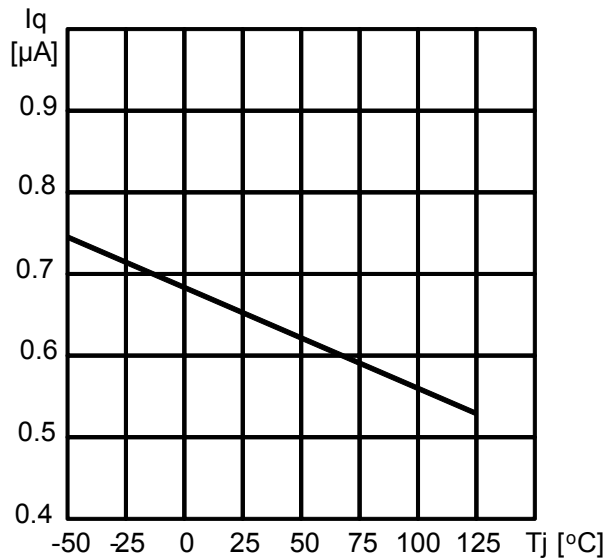

## 7 Package information

In order to meet environmental requirements, ST offers these devices in different grades of **ECOPACK** packages, depending on their level of environmental compliance. ECOPACK specifications, grade definitions and product status are available at: [www.st.com](http://www.st.com). ECOPACK is an ST trademark.

### 7.1 SO-8 package information

Figure 7. SO-8 mechanical data

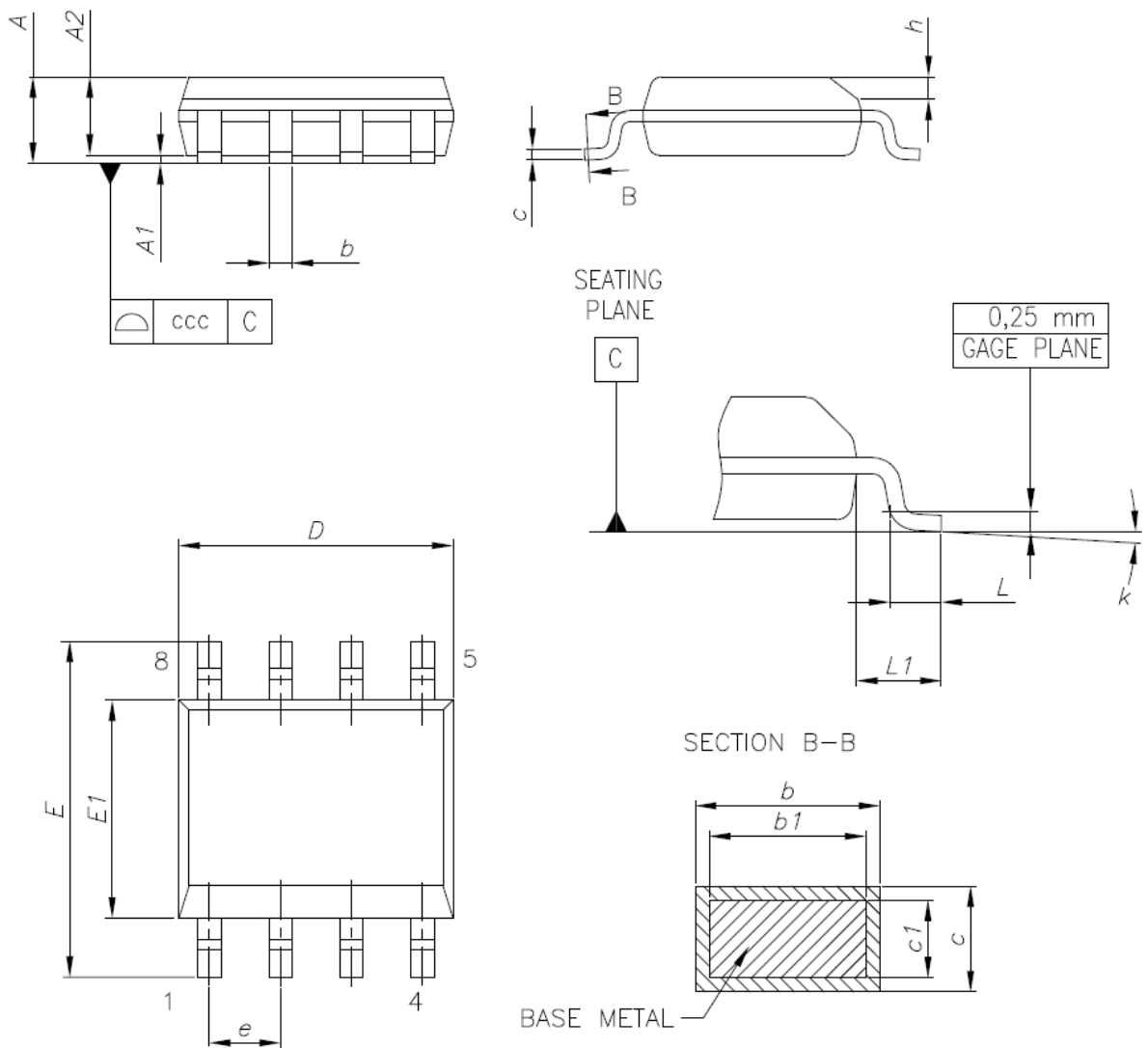
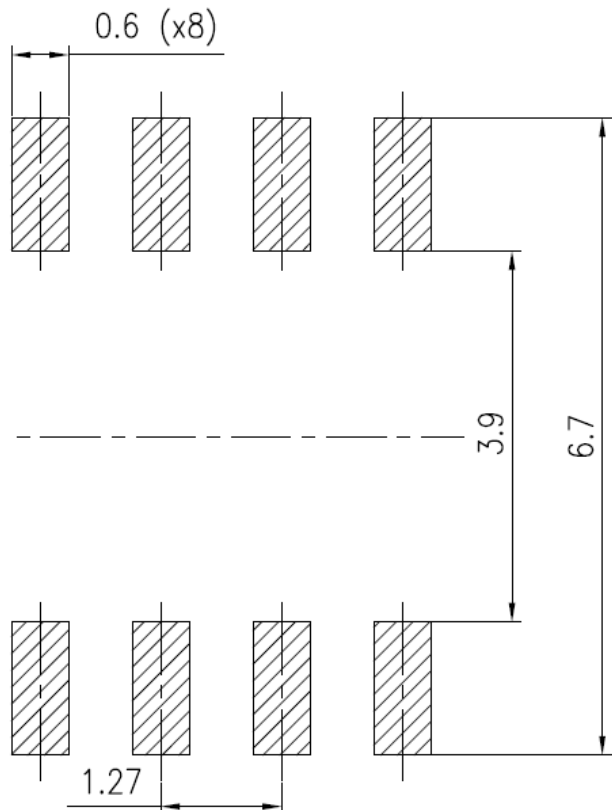



Table 6. SO-8 mechanical data

Dim.	mm		
	Min.	Typ.	Max.
A			1.75
A1	0.10		0.25
A2	1.25		
b	0.31		0.51
b1	0.28		0.48
c	0.10		0.25
c1	0.10		0.23
D	4.80	4.90	5.00
E	5.80	6.00	6.20
E1	3.80	3.90	4.00
e		1.27	
h	0.25		0.50
L	0.40		1.27
L1		1.04	
L2		0.25	
k	0°		8°
ccc			0.10

Figure 8. SO-8 recommended footprint (dimensions are in mm)



## 7.2 SO-8 packing information

Figure 9. SO-8 tape and reel dimensions

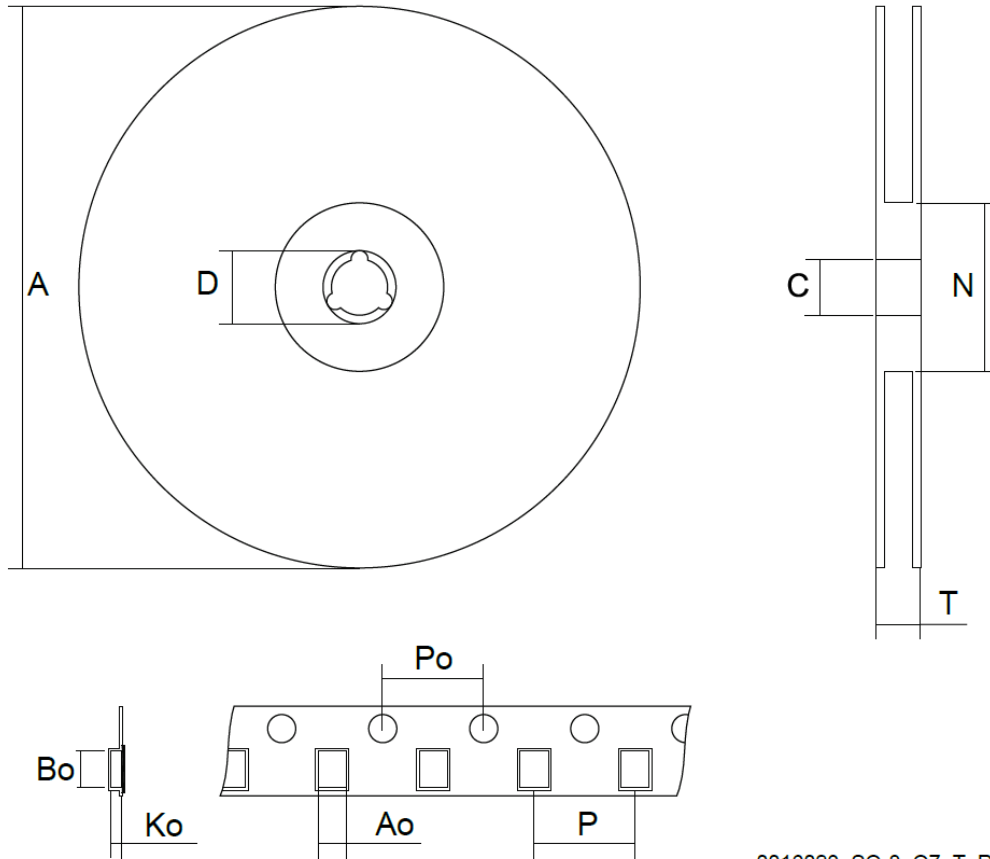
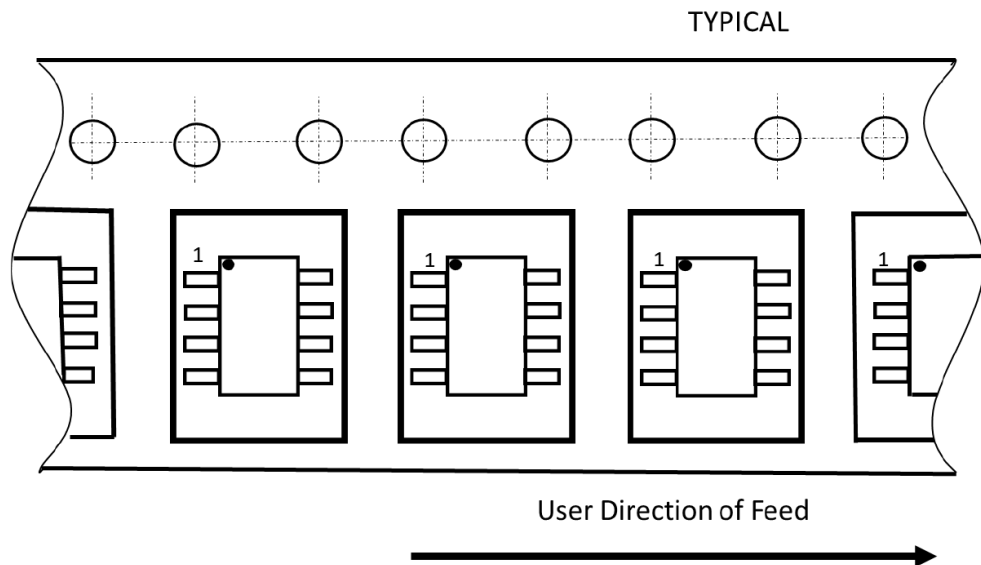

Figure 10. Tape orientation



**Table 7. SO-8 tape and reel mechanical data**

Dim.	mm		
	Min.	Typ.	Max.
A			330
C	12.8		13.2
D	20.2		
N	60		
T			22.4
Ao	6.5	-	6.7
Bo	5.4		5.6
Ko	2.0		2.2
Po	3.9		4.1
P	7.9		8.1

## 8 Ordering information

**Table 8. Ordering information**

Order code	Package	Packing
TDE1707BFP	SO-8	Tube
TDE1707BFPT		Tape and reel
TDE1707CFP		Tube
TDE1707CFPT		Tape and reel

## Revision history

**Table 9. Document revision history**

Date	Version	Changes
03-Dec-2021	1	Initial release.

---

## Contents

<b>1</b>	<b>Block diagram</b> .....	<b>2</b>
<b>2</b>	<b>Pin configuration</b> .....	<b>3</b>
<b>3</b>	<b>Maximum ratings</b> .....	<b>4</b>
<b>4</b>	<b>Electrical characteristics</b> .....	<b>5</b>
<b>5</b>	<b>Application information</b> .....	<b>6</b>
<b>6</b>	<b>Thermal behavior</b> .....	<b>7</b>
<b>7</b>	<b>Package information</b> .....	<b>8</b>
	7.1 SO-8 package information .....	8
	7.2 SO-8 packing information .....	10
<b>8</b>	<b>Ordering information</b> .....	<b>12</b>
	<b>Revision history</b> .....	<b>13</b>

## List of figures

Figure 1.	Block diagram . . . . .	2
Figure 2.	Pin connections (top view) . . . . .	3
Figure 3.	Application circuit . . . . .	6
Figure 4.	Input threshold voltage vs. temperature ( $V_S = 24\text{ V}$ ) . . . . .	7
Figure 5.	Saturation voltage vs. temperature ( $V_S = 24\text{ V}$ ; $I_O = 500\text{ mA}$ ) . . . . .	7
Figure 6.	Quiescent current vs. temperature ( $V_S = 24\text{ V}$ ) . . . . .	7
Figure 7.	SO-8 mechanical data . . . . .	8
Figure 8.	SO-8 recommended footprint (dimensions are in mm) . . . . .	9
Figure 9.	SO-8 tape and reel dimensions . . . . .	10
Figure 10.	Tape orientation . . . . .	10

## List of tables

<b>Table 1.</b>	Pin description . . . . .	3
<b>Table 2.</b>	Absolute maximum ratings . . . . .	4
<b>Table 3.</b>	Thermal data . . . . .	4
<b>Table 4.</b>	Electrical characteristics . . . . .	5
<b>Table 5.</b>	Dynamic characteristics . . . . .	6
<b>Table 6.</b>	SO-8 mechanical data . . . . .	9
<b>Table 7.</b>	SO-8 tape and reel mechanical data . . . . .	11
<b>Table 8.</b>	Ordering information . . . . .	12
<b>Table 9.</b>	Document revision history . . . . .	13



**IMPORTANT NOTICE – PLEASE READ CAREFULLY**

STMicroelectronics NV and its subsidiaries (“ST”) reserve the right to make changes, corrections, enhancements, modifications, and improvements to ST products and/or to this document at any time without notice. Purchasers should obtain the latest relevant information on ST products before placing orders. ST products are sold pursuant to ST’s terms and conditions of sale in place at the time of order acknowledgement.

Purchasers are solely responsible for the choice, selection, and use of ST products and ST assumes no liability for application assistance or the design of Purchasers’ products.

No license, express or implied, to any intellectual property right is granted by ST herein.

Resale of ST products with provisions different from the information set forth herein shall void any warranty granted by ST for such product.

ST and the ST logo are trademarks of ST. For additional information about ST trademarks, please refer to [www.st.com/trademarks](http://www.st.com/trademarks). All other product or service names are the property of their respective owners.

Information in this document supersedes and replaces information previously supplied in any prior versions of this document.

© 2021 STMicroelectronics – All rights reserved