

May.1.2023 Copyright 2023 HIROSE ELECTRIC CO., LTD. All Rights Reserved.
In case of consideration for using Automotive equipment / device which demand high reliability, kindly contact our sales window correspondents.

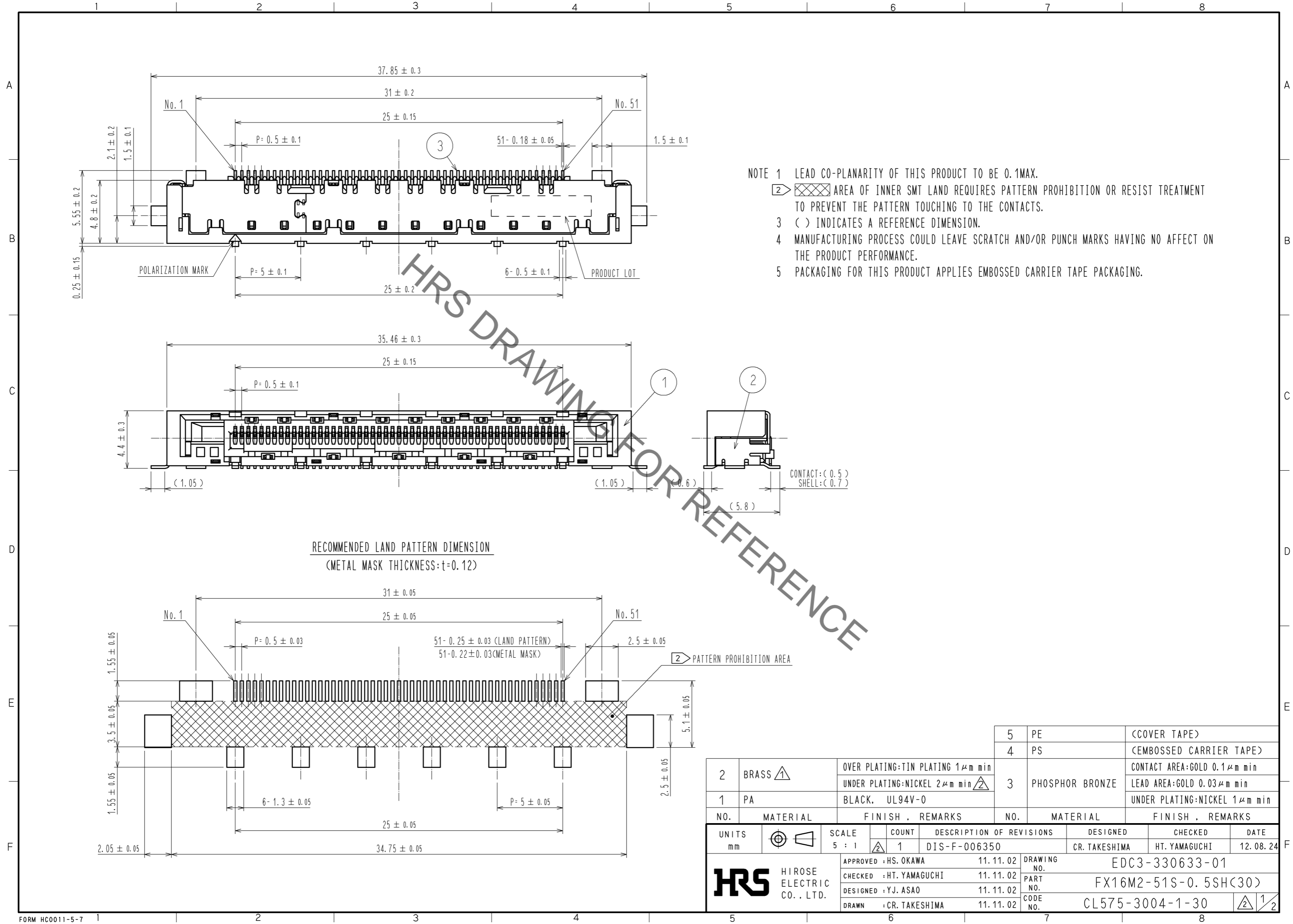

- NOTE 1 LEAD CO-PLANARITY OF THIS PRODUCT TO BE 0.1MAX.
 2 AREA OF INNER SMT LAND REQUIRES PATTERN PROHIBITION OR RESIST TREATMENT TO PREVENT THE PATTERN TOUCHING TO THE CONTACTS.
 3 () INDICATES A REFERENCE DIMENSION.
 4 MANUFACTURING PROCESS COULD LEAVE SCRATCH AND/OR PUNCH MARKS HAVING NO AFFECT ON THE PRODUCT PERFORMANCE.
 5 PACKAGING FOR THIS PRODUCT APPLIES EMBOSSED CARRIER TAPE PACKAGING.

RECOMMENDED LAND PATTERN DIMENSION
(METAL MASK THICKNESS: t=0.12)

2	BRASS	OVER PLATING:TIN PLATING 1μm min UNDER PLATING:NICKEL 2μm min	5	PE	(COVER TAPE)
1	PA	BLACK. UL94V-0	4	PS	(EMBOSSED CARRIER TAPE)
			3	PHOSPHOR BRONZE	CONTACT AREA:GOLD 0.1μm min LEAD AREA:GOLD 0.03μm min UNDER PLATING:NICKEL 1μm min
NO.	MATERIAL	FINISH . REMARKS	NO.	MATERIAL	FINISH . REMARKS
UNITS mm		SCALE 5 : 1	COUNT 1	DESCRIPTION OF REVISIONS DESIGNED CHECKED DATE	
APPROVED : HS. OKAWA 11.11.02			DRAWING NO. EDC3-330633-01		
CHECKED : HT. YAMAGUCHI 11.11.02			PART NO. FX16M2-51S-0.5SH(30)		
DESIGNED : YJ. ASAO 11.11.02			CODE NO. CL575-3004-1-30		
DRAWN : CR. TAKESHIMA 11.11.02			1/2		

May.1.2023 Copyright 2023 HIROSE ELECTRIC CO., LTD. All Rights Reserved.
In case of consideration for using Automotive equipment / device which demand high reliability, kindly contact our sales window correspondents.

DRAWING FOR PACKING (2:1)

THE DIRECTION OF PULLING OUT

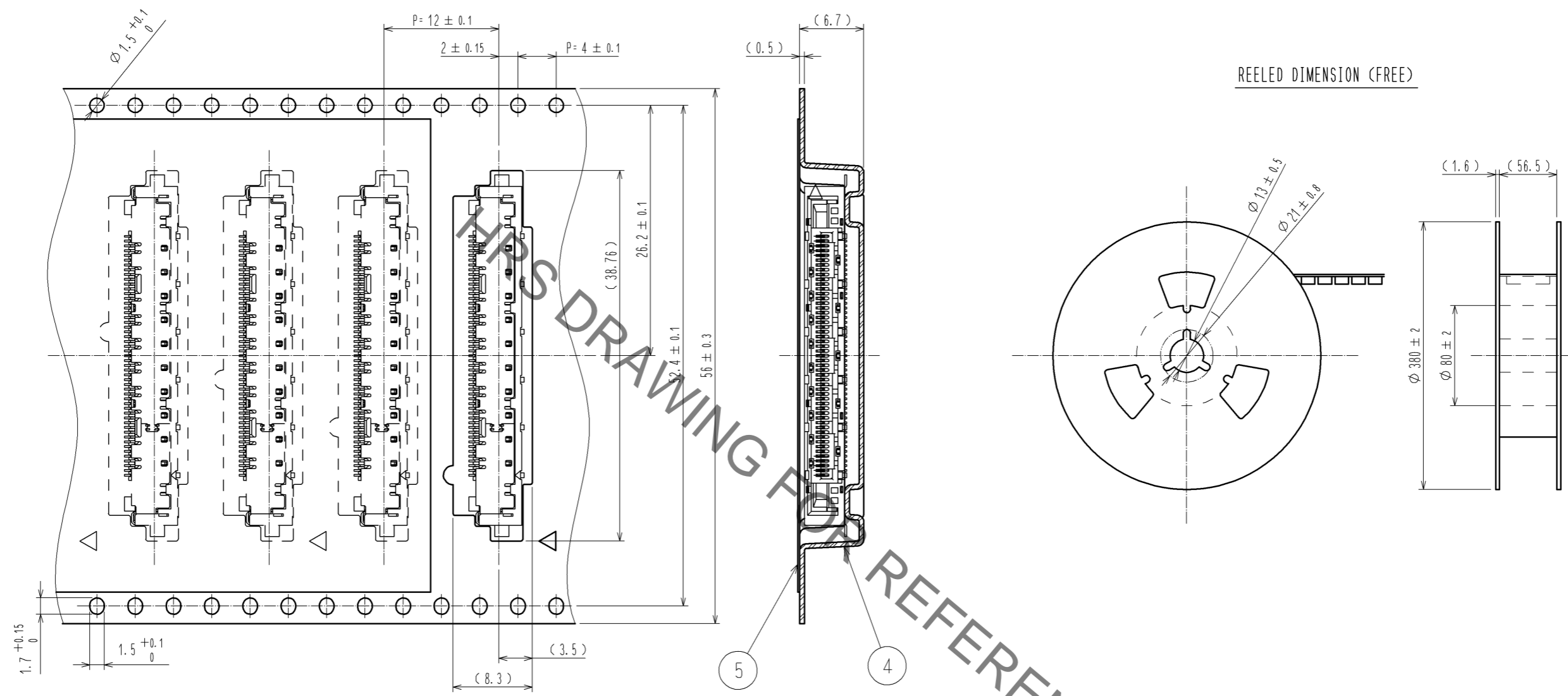
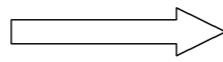

REELED DIMENSION (FREE)

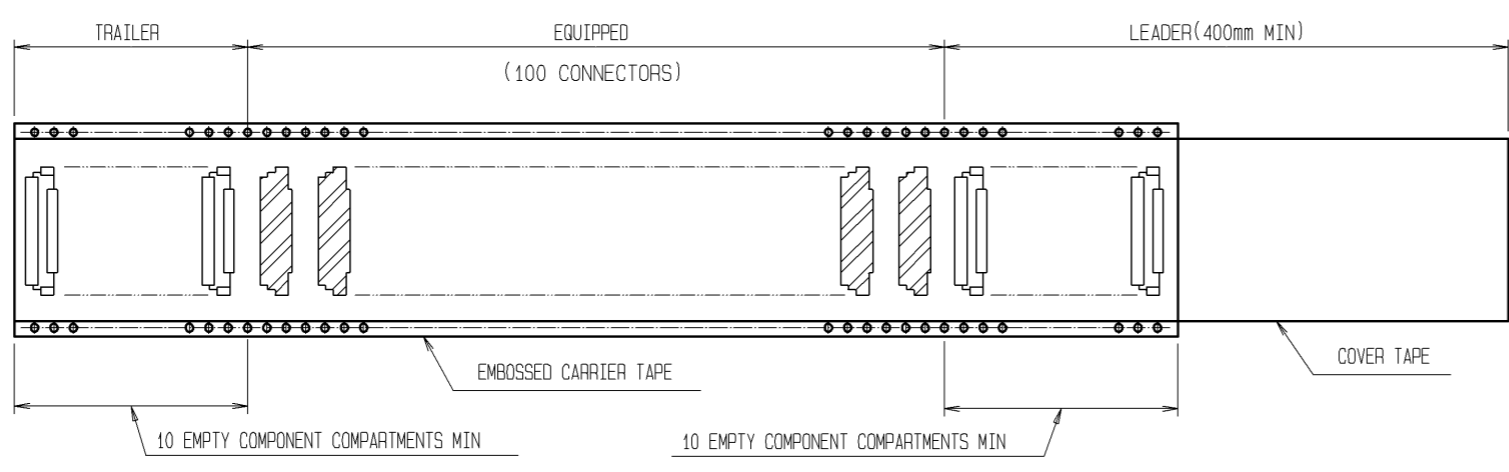
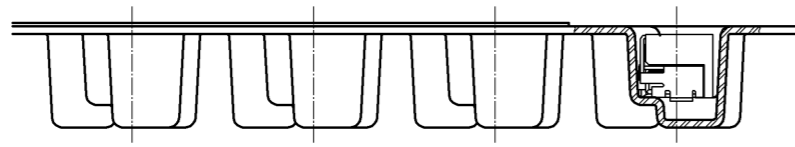
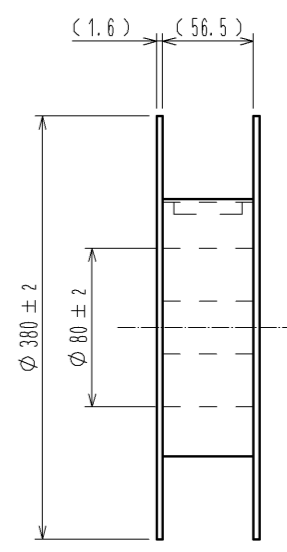

HRS DRAWING FOR REFERENCE

HRS	DRAWING NO.	EDC3-330633-01	
	PART NO.	FX16M2-51S-0.5SH(30)	
	CODE NO.	CL575-3004-1-30	2/2