

# DELKIN DEVICES®

## G630 Series

### Embedded Multimedia Card

e•MMC™ 5.1 HS400

Engineering Specification

Document Number: 401-0511-00

Revision: A



## TABLE OF CONTENTS

<b>Product Features :</b> .....	<b>3</b>
<b>1. Introduction</b> .....	<b>4</b>
<b>2. Specification</b> .....	<b>4</b>
<b>2.1. System Performance</b> .....	<b>4</b>
<b>2.1.1.HS400 (PSA Pseudo-SLC Burst Status)</b> .....	<b>4</b>
<b>2.1.2.HS400 (Normal Status)</b> .....	<b>4</b>
<b>2.2. Power Consumption</b> .....	<b>5</b>
<b>2.3. Capacity by Partition</b> .....	<b>5</b>
<b>2.4. User Density</b> .....	<b>5</b>
<b>3. eMMC™ Device and System</b> .....	<b>6</b>
<b>3.1. eMMC™ System Overview</b> .....	<b>6</b>
<b>3.2. Memory Addressing</b> .....	<b>6</b>
<b>3.3. eMMC™ Device Overview</b> .....	<b>7</b>
<b>3.3.1 Clock (CLK)</b> .....	<b>7</b>
<b>3.3.2 Data Strobe (DS)</b> .....	<b>7</b>
<b>3.3.3 Command (CMD)</b> .....	<b>7</b>
<b>3.3.4 Input/Outputs (DAT0-DAT7)</b> .....	<b>7</b>
<b>4. eMMC™ Functional Description</b> .....	<b>8</b>
<b>4.1. Field Firmware Update(FFU)</b> .....	<b>8</b>
<b>4.2 Power off Notification for Sleep</b> .....	<b>9</b>
<b>4.3 Enhanced Use Data Area</b> .....	<b>10</b>
<b>4.4 Write Cache</b> .....	<b>10</b>
<b>4.5 Cache Enhancement Barrier</b> .....	<b>11</b>
<b>4.6 Cache Flushing Policy</b> .....	<b>12</b>
<b>5. Register Settings</b> .....	<b>14</b>
<b>6. Package Connections</b> .....	<b>24</b>
<b>6.1.Package Mechanical</b> .....	<b>24</b>
<b>6.1.1. 11.5 x 13.0 x 1mm 153 Ball Package</b> .....	<b>24</b>
<b>7. Ball Assignments</b> .....	<b>26</b>
<b>7.1.153 Ball Package</b> .....	<b>26</b>
<b>8. Signal Description</b> .....	<b>27</b>
<b>9. Ordering Information</b> .....	<b>27</b>

## Product Features :

- Packaged NAND flash memory with e•MMC™ 5.1 interface
- Compliant with e•MMC™ Specification Ver.4.4, 4.41,4.5, 5.0 and 5.1
- Bus mode
  - High-speed e•MMC™ protocol
  - Clock frequency: 0-200MHz.
  - Ten-wire bus (clock, 1 bit command, 8 bit data bus) and a hardware reset.
- Supports three different data bus widths: 1 bit(default), 4 bits, 8 bits
  - Data transfer rate: up to 52Mbyte/s (using 8 parallel data lines at 52 MHz)
  - Single data rate: up to 200Mbyte/s @ 200MHz
  - Dual data rate: up to 400Mbytes/s @200MHz
- Operating voltage range:
  - VCCQ = 1.8 V/3.3 V
  - VCC = 3.3 V
- Error free memory access
  - Internal error correction code (ECC) to protect data communication
  - Internal enhanced data management algorithm
  - Solid protection of sudden power failure safe-update operations for data content
- Security
  - Supports secure bad block erase commands
  - Enhanced Write Protection with permanent and partial protection options
- Quality
  - RoHS compliant (for detailed RoHS declaration, please contact your Delkin representative.)
- Supports Field Firmware Update (FFU)
- Enhanced Device Life Time
- Supports pre EOL information
- Supports Production State Awareness
- Supports Power Off Notification for Sleep
- Supports HS400
- Major Supported eMMC 5.1 Features:
  - Command Queuing, Enhanced Strobe, Cache Flushing Report, BKOPS Control, Cache Barrier, RPMB Throughput Improve, Secure Write Protection.
- Temperature Range:
  - Operating: -40 to +85°C
  - Storage: -40 to +85°C

## 1. Introduction

Delkin Devices e•MMC™ products comply with the JEDEC e•MMC™ 5.1 standard and are an ideal universal storage solution for many embedded devices. E•MMC™ combines TLC NAND and an e•MMC™ controller inside one JEDEC standard package, providing a standard interface to the host. Delkin offers the 153 ball (11.5 x 13 x 1.0mm package), in TLC configuration. The e•MMC™ controller directly manages NAND flash, including ECC, wear-leveling, IOPS optimization and read sensing.

**Table 1 – Device Summary**

Flash Configuration	Available Capacities	Package	Operating Voltage
TLC	32GB – 64GB	FBGA153 11.5 x 13 x 1.0mm	V <sub>CC</sub> =3.3V, V <sub>CCQ</sub> =1.8V/3.3V

Refer to part number table in Section 10.

## 2. Specification

### 2.1. System Performance

#### 2.1.1. HS400 (PSA Pseudo-SLC Burst Status)

**Table 2- Read/Write Performance during PSA**

Capacity	Write Cache On		Write Cache Off	
	Read Sequential (MB/s)	Write Sequential (MB/s)	Read Sequential (MB/s)	Write Sequential (MB/s)
32GB	260	110	270	100
64GB	280	220	290	190

Note 1: Values given for an 8-bit bus width, running HS400 mode V<sub>CC</sub>=3.3V, V<sub>CCQ</sub>=1.8V.  
 Note 2: Performance numbers might be subject to changes without notice.  
 Note 3: The write cache size is 128KB.

#### 2.1.2. HS400 (Normal Status)

**Table 3- Read/Write Performance without PSA**

Capacity	Write Cache On		Write Cache Off	
	Read Sequential (MB/s)	Write Sequential (MB/s)	Read Sequential (MB/s)	Write Sequential (MB/s)
32GB	260	20	270	20
64GB	280	40	290	40

Note 1: Values given for an 8-bit bus width, running HS400 mode V<sub>CC</sub>=3.3V, V<sub>CCQ</sub>=1.8V.  
 Note 2: Performance numbers might be subject to changes without notice.  
 Note 3: The write cache size is 128KB.

## 2.2. Power Consumption

**Table 4–Device Power Consumption**

Products	Read (mA)		Write mA)		Standby (uA)	
	V <sub>CCQ</sub> (1.8V)	V <sub>CC</sub> (3.3V)	V <sub>CCQ</sub> (1.8V)	V <sub>CC</sub> (3.3V)	V <sub>CCQ</sub> (1.8V)	V <sub>CC</sub> (3.3V)
32GB	110	70	60	50	90	40
64GB	120	80	80	80	110	50

Note 1; Values given for an 8-bit bus width, a clock frequency of 200MHz DDR mode, VCC= 3.3V±5%, VCCQ=1.8V±5%.  
 Note 2: Standby current is measured at Vcc = 3.3V ±5%, 8-bit bus width without clock frequency  
 Note 3: Current numbers might be subject to change without notice.  
 Note 4: The measurement for max RMS current is done as average RMS current consumption over a period of 100ms.

## 2.3. Capacity by Partition

Device	Boot Partition 1	Boot Partition 2	RPMB
32GB	4096 KB	4096 KB	4096 KB
64GB	4096 KB	4096 KB	4096 KB

## 2.4. User Density

Device	User Density
32GB	31,281,119,232 Bytes
64GB	62,562,238,464 Bytes

### 3. eMMC™ Device and System

#### 3.1. eMMC™ System Overview

The eMMC™ specification covers the behavior of the interface and the Device controller. As part of this specification, the existence of a host controller and a memory storage array are implied but the operation of these pieces is not fully specified.

Delkin's NAND device consists of a single chip MMC controller and NAND flash memory module. The micro-controller interfaces with a host system allowing data to be written to and read from the NAND flash memory module. The controller allows the host to be independent from details of erasing and programming the flash memory.

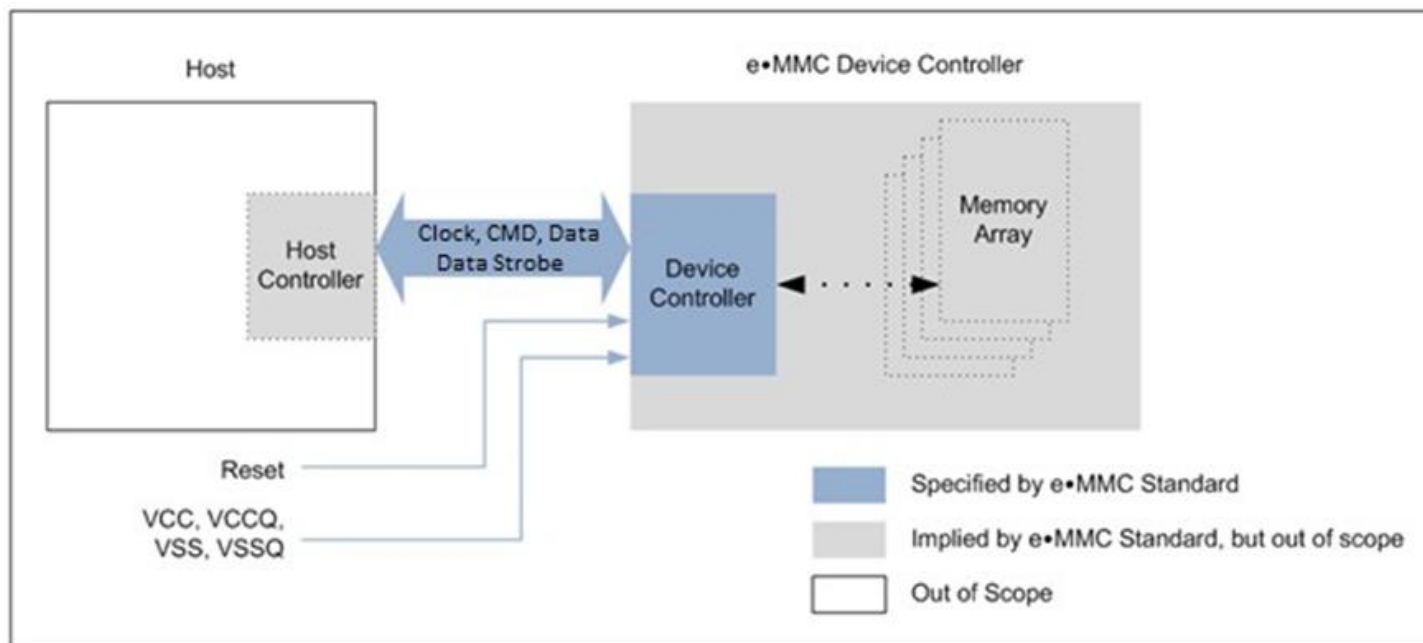

Figure 1– eMMC™ System Overview

#### 3.2. Memory Addressing

Previous implementations of the eMMC™ specification follow byte addressing with 32 bit field. This addressing mechanism is permitted for eMMC™ densities up to and including 2 GB.

To support larger densities the addressing mechanism was updated to support sector addresses (512 B sectors). The sector addresses shall be used for all devices with capacity larger than 2 GB. To determine the addressing mode use the host should read bit [30:29] in the OCR register.

### 3.3. eMMC™ Device Overview

The eMMC™ device transfers data via a configurable number of data bus signals. The communication signals are:

#### 3.3.1 Clock (CLK)

Each cycle of this signal directs a one-bit transfer on the command and either a one bit (1x) or two bit transfer (2x) on all the data lines. The frequency may vary between zero and the maximum clock frequency.

#### 3.3.2 Data Strobe (DS)

This signal is generated by the device and used for output in HS400 mode. The frequency of this signal follows the frequency of CLK. For data output each cycle of this signal directs two bits transfer (2x) on the data - one bit for positive edge and the other bit for negative edge. For CRC status response output and CMD response output (enabled only HS400 enhanced strobe mode), the CRC status is latched on the positive edge only, and ignores the negative edge.

#### 3.3.3 Command (CMD)

This signal is a bidirectional command channel used for Device initialization and transfer of commands. The CMD signal has two operation modes: open-drain for initialization mode, and push-pull for fast command transfer. Commands are sent from the eMMC™ host controller to the eMMC™ Device and responses are sent from the Device to the host.

#### 3.3.4 Input/Outputs (DAT0-DAT7)

These are bidirectional data channels. The DAT signals operate in push-pull mode. Either the Device or the host is driving these signals at any given time. By default, after power up or reset, only DAT0 is used for data transfer. A wider data bus can be configured for data transfer, using either DAT0-DAT3 or DAT0-DAT7, by the eMMC™ host controller. The eMMC™ Device includes internal pull-ups for data lines DAT1-DAT7. Immediately after entering 4-bit mode, the Device disconnects the internal pull ups of lines DAT1, DAT2, and DAT3. Correspondingly, immediately after entering 8-bit mode, the Device disconnects the internal pull-ups of lines DAT1–DAT7.

Table 5– Communication Interface

Name	Type <sup>1</sup>	Description
CLK	I	Clock
DAT0	I/O/PP	Data
DAT1	I/O/PP	Data
DAT2	I/O/PP	Data
DAT3	I/O/PP	Data
DAT4	I/O/PP	Data
DAT5	I/O/PP	Data
DAT6	I/O/PP	Data
DAT7	I/O/PP	Data
CMD	I/O/PP/OD	Command/Response
RST_n	I	Hardware reset
VCC	S	Supply voltage for Core
VCCQ	S	Supply voltage for I/O
VSS	S	Supply voltage ground for Core
VSSQ	S	Supply voltage ground for I/O
DS	O/PP	Data strobe

Note1 : I: input; O: output; PP: push-pull; OD: open-drain; NC: Not connected (or logical high); S: power supply.

## 4. eMMC™ Functional Description

### 4.1. Field Firmware Update (FFU)

Field Firmware Updates (FFU) enables features enhancement in the field. Using this mechanism the host downloads a new version of the firmware to the e.MMC device and, following a successful download, instructs the e.MMC device to install the new downloaded firmware into the device.

In order to start the FFU process the host first checks if the e.MMC device supports FFU capabilities by reading SUPPPORTED\_MODES and FW\_CONFIG fields in the EXT\_CSD. If the e.MMC device supports the FFU feature the host may start the FFU process. The FFU process starts by switching to FFU Mode in MODE\_CONFIG field in the EXT\_CSD. In FFU Mode host should use closed-ended or open ended commands for downloading the new firmware and reading vendor proprietary data. In this mode, the host should set the argument of these commands to be as defined in FFU\_ARG field. In case these commands have a different argument the device behavior is not defined and the FFU process may fail. The host should set Block Length to be DATA\_SECTOR\_SIZE. Downloaded firmware bundle must be DATA\_SECTOR\_SIZE size aligned (internal padding of the bundle might be required). Once in FFU Mode the host may send the new firmware bundle to the device using one or more write commands.

The host could regain regular functionality of write and read commands by setting MODE\_CONFIG field in the EXT\_CSD back to Normal state. Switching out of FFU Mode may abort the firmware download operation. When host switched back to FFU Mode, the host



should check the FFU Status to get indication about the number of sectors which were downloaded successfully by reading the `NUMBER_OF_FW_SECTORS_CORRECTLY_PROGRAMMED` in the extended CSD. In case the number of sectors downloaded successfully is zero, the host should re-start downloading the new firmware bundle from its first sector. In case the number of sectors which were downloaded successfully is positive, the host should continue the download from the next sector, which would resume the firmware download operation.

In case `MODE_OPERATION_CODES` field is not supported by the device, the host sets to `NORMAL` state and initiates a `CMD0/HW_Reset/Power` cycle to install the new firmware. In such case the device doesn't need to use `NUMBER_OF_FW_SECTORS_CORRECTLY_PROGRAMMED`.

In both cases, occurrence of a `CMD0/HW_Reset/Power` before the host successfully downloaded the new firmware bundle to the device may cause the firmware download process to be aborted.

## 4.2 ***Power off Notification for Sleep***

The host should notify the device before it powers the device off – by turning off all of its power supplies. This allows the device to better prepare itself for power down. In particular, the host should issue a power off notification (`POWER_OFF_LONG`, `POWER_OFF_SHORT`) if it intends to turn off both `VCC` and `VCCQ` power or it may use a power off notification (`SLEEP_NOTIFICATION`) if it intends to turn-off `VCC` after moving the device to Sleep state.

To indicate to the device that power off notification is supported by the host, a supporting host shall first set the `POWER_OFF_NOTIFICATION` byte in `EXT_CSD` [34] to `POWERED_ON` (0x01). To execute a power off, before powering the device down, the host will change the value to either `POWER_OFF_SHORT` (0x02) or `POWER_OFF_LONG` (0x03). The host should wait for the busy line to be de-asserted. Once the setting has changed to either 0x02 or 0x03, host may safely power off the device.

The host may issue `SLEEP_AWAKE` (`CMD5`) to enter or to exit from Sleep state if `POWER_OFF_NOTIFICATION` byte is set to `POWERED_ON`. Before moving to Standby state and then to Sleep state, the host sets `POWER_OFF_NOTIFICATION` to `SLEEP_NOTIFICATION` and waits for the `DAT0` line de-assertion. While in Sleep (`slp`) state, `VCC` (Memory supply) may be turned off as defined in 4.1.6. Removing power supplies other than `VCC` while the device is in the Sleep (`slp`) state may result in undefined device behavior. Before removing all power supplies, the host should transition the device out of Sleep (`slp`) state back to Transfer state using `CMD5` and `CMD7` and then execute a power off notification setting `POWER_OFF_NOTIFICATION` byte to either `POWER_OFF_SHORT` or `POWER_OFF_LONG`.

If host continues to send commands to the device after switching to the power off setting (`POWER_OFF_LONG`, `POWER_OFF_SHORT` or `SLEEP_NOTIFICATION`) or performs HPI

during the busy condition, the device shall restore the POWER\_OFF\_NOTIFICATION byte to POWERED\_ON.

If the host tries to change POWER\_OFF\_NOTIFICATION to 0x00 after writing another value there, a SWITCH\_ERROR is generated.

The difference between the two power-off modes is the urgency with which the host wants to turn power off. The device should respond to POWER\_OFF\_SHORT quickly under the generic CMD6 timeout. If more time is acceptable, POWER\_OFF\_LONG may be used and the device shall respond to it within the POWER\_OFF\_LONG\_TIME timeout.

While POWER\_OFF\_NOTIFICATION is set to POWERED\_ON, the device expects the host to host shall:

- Keep the device power supplies alive (both VCC and VCCQ) and in their active mode
- Not power off the device intentionally before changing POWER\_OFF\_NOTIFICATION to either POWER\_OFF\_LONG or POWER\_OFF\_SHORT
- Not power off VCC intentionally before changing POWER\_OFF\_NOTIFICATION to SLEEP\_NOTIFICATION and before moving the device to Sleep state

Before moving to Sleep state, hosts may set the POWER\_OFF\_NOTIFICATION byte to SLEEP\_NOTIFICATION (0x04) if aware that the device is capable of autonomously initiating background operations for possible performance improvements. Host should wait for the busy line to be de-asserted. Busy line may be asserted up the period defined in SLEEP\_NOTIFICATION\_TIME byte in EXT\_CSD [216]. Once the setting has changed to 0x04 host may set the device into Sleep mode (CMD7+CMD5). After exiting from Sleep, the POWER\_OFF\_NOTIFICATION byte will restore its value to POWERED\_ON. HPI may interrupt the SLEEP\_NOTIFICATION operation. In that case POWER\_OFF\_NOTIFICATION byte will restore to POWERED\_ON.

### **4.3 Enhanced Use Data Area**

Delkin eMMC supports Enhanced User Data Area feature which allows the User Data Area of eMMC to be configured as SLC Mode. Therefore, when host set the Enhanced User Data Area, the area will occupy more size of original set up size. The Max Enhanced User Data Area size is defined as - (MAX\_ENH\_SIZE\_MULT x HC\_WP\_GRP\_SIZE x HC\_ERASE\_GRP\_SIZE x 512 KBytes). The Enhanced use data area size is defined as - (ENH\_SIZE\_MULT x HC\_WP\_GRP\_SIZE x HC\_ERASE\_GRP\_SIZE x 512 KBytes). The host shall follow the flow chart of JEDEC spec for configuring the parameters of General Purpose Area Partitions and Enhanced User Data Area.

### **4.4 Write Cache**

Cache is a temporary storage space in an eMMC device. The cache should in typical case reduce the access time and increase the speed (compared to an access to the main nonvolatile storage). The cache is not directly accessible by the host. This temporary storage

space may be utilized also for some implementation specific operations like as an execution memory for the memory controller and/or as storage for an address mapping table etc. However, there is data inconsistency risk when using nonvolatile cache. It's recommend only turning on the cache for the application which requires not too high reliability.

The cache shall be OFF by default after power up, RST\_n assertion or CMD0. All accesses shall be directed to the nonvolatile storage like defined elsewhere in this specification. The cache function can be turned ON and OFF by writing to the CACHE\_CTRL byte (EXT\_CSD byte [33]). Turning the cache ON shall enable behavior model defined in this section. Turning the cache OFF shall trigger flushing of the data to the nonvolatile storage.

## 4.5 Cache Enhancement Barrier

Barrier function provides a way to perform a delayed in-order flushing of a cached data. The main motivation for using barrier commands is to avoid the long delay that is introduced by flush commands. There are cases where the host is not interested in flushing the data right away, however it would like to keep an order between different cached data batches. The barrier command enables the host achieving the in-order goal but without paying the flush delay, since the real flushing can be delayed by the device to some later idle time. The formal definition of the barrier rule is as follows:

Denote a sequence of requests  $R_i$ ,  $i=0,..,N$ . Assuming a barrier is set between requests  $R_x$  and  $R_{x+1}$  ( $0 < x < N$ ) then all the requests  $R_0..R_x$  must be flushed to the non-volatile memory before any of the requests  $R_{x+1}..R_N$ .

Between two barriers the device is free to write data into the non-volatile memory in any order. If the host wants to preserve a certain order it shall flush the cache or set another barrier at a point where order is important.

The barrier is set by writing to the BARRIER bit of the FLUSH\_CACHE byte (EXT\_CSD byte [32]). Any error resulted can be read from the status register by CMD13 after the completion of the programming as defined for a normal write request. The error could affect any data written to the cache since the previous flush operation.

The device shall support any number of barrier commands between two flush commands. In case of multiple barrier commands between two flush commands a subset of the cached data may be committed to the non-volatile memory according to the barrier rule. Internally, a device may have an upper limit on the barrier amount it can absorb without flushing the cache. That is, if the host exceeds this barrier amount, the device may issue, internally, a normal flush.

The device shall expose its barrier support capability via the BARRIER\_SUPPORT byte (EXT\_CSD byte [486]). If a device does not support barrier function this register shall be zero. If a device supports barrier function this register shall be one.

Assuming the device supports barrier function, if the BARRIER bit of the FLUSH\_CACHE byte is set, a barrier operation shall be executed.

If the cache gets totally full and/or the cache is not able to receive the data of the next access (per block count indicated in CMD23 or per initiated single / open ended multiple block write in general) then it shall still be the responsibility of the eMMC device to store the data of the next access within the timeouts that are specified elsewhere in this specification. The actual algorithm to handle the new data and possible flush of some older cached data is left for the implementation.

Note: When issuing a force-programming write request (CMD23 with bit 24 on) or a reliable write request (CMD23 with bit 31 on), the host should be aware that the data will be written to the non-volatile memory, potentially, before any cached data, even if a barrier command was issued.

Therefore, if the writing order to the non-volatile memory is important, it is the responsibility of the host to issue a flush command before the force-programming or the reliable-write request. In order to use the barrier function, the host shall set bit 0 of BARRIER\_EN (EXT\_CSD byte [31]). The barrier feature is optional for an eMMC device.

## 4.6 Cache Flushing Policy

The host may require the device to flush data from the cache in an in-order manner. From time to time, to guarantee in-order flushing, the host may command the device to flush the device cache or may use a barrier command.

However, if the eMMC device flushing policy is to flush data from the cache in an in-order manner, cache barrier commands or flush commands operations (In case goal is to guarantee the flushing order) are redundant and impose a needless overhead to the device and host.

FIFO bit in CACHE\_FLUSH\_POLICY field (EXT\_CSD byte [240]) is used by the device to indicate to the host that the device cache flushing policy is First-In-First-Out; this means that the device guarantees that the order of the flushing of data would be the in same order which data was written to the cache. When the FIFO bit is set it is recommended for the host not to send cache barrier commands or flush operations which goal is to guarantee the flushing order as they are redundant and impose a burden to the system.

However, if the FIFO bit is set to 1b and the device supports the cache barrier mechanism, the host may still send barrier commands without getting an error. Sending these commands will not change the device behavior as device flushes cache in-order anyway.

The CACHE\_FLUSH\_POLICY field is read-only field and never change its value either by the host or device.

## **4.7 Command Queuing (Disabled by default)**

To facilitate command queuing in eMMC, the device manages an internal task queue to which the host can queue data transfer tasks.

Initially the task queue is empty. Every task is issued by the host and initially queued as pending. The device controller works to prepare pending tasks for execution. When a task is ready for execution its state changes to “ready for execution”. The exact meaning of “ready for execution” is left for device implementation.

The host tracks the state of all queued tasks and may order the execution of any task, which is marked as “ready for execution” by sending a command indicating its task ID. When the execute command is received (CMD46/CMD47) the device executes the data transfer transaction.

For example, in order to queue a write transaction, the host sends a CMD44 indicating the task’s parameters. The device responds and the host sends a CMD45, indicating the start block address.

## **4.8 Production State awareness (PSA)**

The eMMC device could utilize the information of whether it is in production environment and operate differently than it operates in the field.

For example, content that was loaded into the storage device prior to soldering might get corrupted, at higher probability, during device soldering. The eMMC device could use “special” internal operations for loading content prior to device soldering that would reduce production failures and use “regular” operations post-soldering.

PRODUCTION\_STATE\_AWARENESS [133] field in extended CSD is used as a mechanism through which the host should report to the device whether it is pre or post soldering state. This standard defines two methods, Manual Mode and Auto Mode, to manage the device production state.

The trigger for starting or re-starting the process is setting correctly

PRE\_LOADING\_DATA\_SIZE field. Before setting this field the host is expected to make sure that the device is clean and any data that was written before to the device is expected to be erased using CMD35, CMD36 and CMD38.

In case the host erased data, overrode existing data or performed re-partition during production state awareness it should restart the production state awareness process by re-setting PRE\_LOADING\_DATA\_SIZE.

Delkin defines Pseudo SLC mode as special internal operation of PSA to have better reliability during the soldering process in production (reflow). Delkin has adopted mechanisms to recover the TLC behavior after the end of production. Once the host used over the threshold, the PSA feature is disabled, and the firmware will start to merge pSLC blocks to TLC blocks to make the drive returns to original situation. Threshold values of PSA are different according to NAND mode:

- TLC – 33% of user capacity

## 5. Register Settings

Within the Device interface six registers are defined: OCR, CID, CSD, EXT\_CSD, RCA and DSR. These can be accessed only by corresponding commands (see Section 6.10 of JESD84-B51).

### 5.1 OCR Register

The 32-bit operation conditions register (OCR) stores the VDD voltage profile of the Device and the access mode indication. In addition, this register includes a status information bit. This status bit is set if the Device power up procedure has been finished. The OCR register shall be implemented by all Devices.

OCR bit	VDD voltage window	High Voltage Value	Dual Voltage Value
[6:0]	Reserved	00 00000b	00 00000b
[7]	1.70 - 1.95V	0b	1b
[14:8]	2.0-2.7V	000 0000b	000 0000b
[23:15]	2.7-3.6V	1 1111 1111b	1 1111 1111b
[28:24]	Reserved	0 0000b	0 0000b
[30:29]	Access Mode	00b (byte mode) 10b (sector mode)	00b (byte mode) 10b (sector mode)
[31]	Device power up status bit (busy) <sup>1</sup>		
Note1 : This bit is set to LOW if the Device has not finished the power up routine.			

### 5.2 CID Register

The Card Identification (CID) register is 128 bits wide. It contains the Device identification information used during the Device identification phase (eMMC protocol). For details, refer to JEDEC Standard Specification..

CID Fields Name	Field	Width	CID slice	Value
Manufacturer ID	MID	8	[127:120]	32h
Reserved	-	6	[119:114]	0h
Device/BGA	CBX	2	[113:112]	1h

OEM/Application ID	OID	8	[111:104]	1h
Product name	PNM	48	[103:56]	32GB - 4D4D4333247h (MMC32G) 64GB - 4D4D43363447h (MMC64G)
Product revision	PRV	8	[55:48]	51h
Product serial number	PSN	32	[47:16]	Random by Production
Manufacturing date	MDT	8	[15:8]	Month, Year
CRC7 checksum	CRC	7	[7:1]	- (Note 1)
Reserved	-	1	[0:0]	1h

### 5.3 CSD Register

The Card-Specific Data (CSD) register provides information on how to access the contents stored in eMMC. The CSD registers are used to define the error correction type, maximum data access time, data transfer speed, data format...etc. For details, refer to section 7.3 of the JEDEC Standard Specification No.JESD84-B51.

Name	Field	Width	Cell Type	CSD-slice	Value
CSD structure	CSD_STRUCTURE	2	R	[127:126]	3h
System specification version	SPEC_VERS	4	R	[125:122]	4h
Reserved	-	2	R	[121:120]	0h
Data read access-time 1	TAAC	8	R	[119:112]	4Fh
Data read access-time 2 in CLK cycles (NSAC*100)	NSAC	8	R	[111:104]	1h
Max. bus clock frequency	TRAN_SPEED	8	R	[103:96]	32h
Device command classes	CCC	12	R	[95:84]	8F5h
Max. read data block length	READ_BL_LEN	4	R	[83:80]	9h
Partial blocks for read allowed	READ_BL_PARTIAL	1	R	[79:79]	0h
Write block misalignment	WRITE_BLK_MISALIGN	1	R	[78:78]	0h
Read block misalignment	READ_BLK_MISALIGN	1	R	[77:77]	0h
DSR implemented	DSR_IMP	1	R	[76:76]	0h

Reserved	-	2	R	[75:74]	0h
Device size	C_SIZE	12	R	[73:62]	FFFh
Max. read current @ VDD min	VDD_R_CURR_MIN	3	R	[61:59]	7h
Max. read current @ VDD max	VDD_R_CURR_MAX	3	R	[58:56]	7h
Max. write current @ VDD min	VDD_W_CURR_MIN	3	R	[55:53]	7h
Max. write current @ VDD max	VDD_W_CURR_MAX	3	R	[52:50]	7h
Device size multiplier	C_SIZE_MULT	3	R	[49:47]	7h
Erase group size	ERASE_GRP_SIZE	5	R	[46:42]	1Fh
Erase group size multiplier	ERASE_GRP_MULT	5	R	[41:37]	1Fh
Write protect group size	WP_GRP_SIZE	5	R	[36:32]	0Fh
Write protect group enable	WP_GRP_ENABLE	1	R	[31:31]	1h
Manufacturer default ECC	DEFAULT_ECC	2	R	[30:29]	0h
Write speed factor	R2W_FACTOR	3	R	[28:26]	2h
Max. write data block length	WRITE_BL_LEN	4	R	[25:22]	9h
Partial blocks for write allowed	WRITE_BL_PARTIAL	1	R	[21:21]	0h
Reserved	-	4	R	[20:17]	0h
Content protection application	CONTENT_PROT_APP	1	R	[16:16]	0h
File format group	FILE_FORMAT_GRP	1	R/W	[15:15]	0h
Copy flag (OTP)	COPY	1	R/W	[14:14]	0h
Permanent write protection	PERM_WRITE_PROTECT	1	R/W	[13:13]	0h
Temporary write protection	TMP_WRITE_PROTECT	1	R/W	[12:12]	0h
File format	FILE_FORMAT	2	R/W	[11:10]	0h
ECC code	ECC	2	R/W	[9:8]	0h
CRC	CRC	7	R/W	[7:1]	2Eh
Reserved	-	1	-	[0:0]	1h

### 5.4 Extended CSD Register

The Extended CSD register defines the Device properties and selected modes. It is 512 bytes long. The most significant 320 bytes are the Properties segment, which defines the Device capabilities and cannot be modified by the host. The lower 192 bytes are the Modes segment, which defines the configuration the Device is working in. These modes can be changed by the host by means of the SWITCH command.



Name	Field	Size (Bytes)	CSD-slice	Value
Reserved	-	6	[511:506]	0h
Extended Security Commands Error	EXT_SECURITY_ERR	1	[505]	0h
Supported Command Sets	S_CMD_SET	1	[504]	1h
HPI features	HPI_FEATURES	1	[503]	1h
Background operations support	BKOPS_SUPPORT	1	[502]	1h
Max packed read commands	MAX_PACKED_READS	1	[501]	3Ch
Max packed write commands	MAX_PACKED_WRITES	1	[500]	20h
Data Tag Support	DATA_TAG_SUPPORT	1	[499]	1h
Tag Unit Size	TAG_UNIT_SIZE	1	[498]	3h
Tag Resources Size	TAG_RES_SIZE	1	[497]	0h
Context management capabilities	CONTEXT_CAPABILITIES	1	[496]	5h
Large Unit size	LARGE_UNIT_SIZE_M1	1	[495]	17h -TLC 32GB 2Fh -TLC 64GB
Extended partitions attribute support	EXT_SUPPORT	1	[494]	3h
Supported modes	SUPPORTED_MODES	1	[493]	2h
FFU features	FFU_FEATURES	1	[492]	0h
Operation codes timeout	OPERATION_CODE_TIME_OUT	1	[491]	0h
FFU Argument	FFU_ARG	4	[490:487]	65535
Barrier support	BARRIER_SUPPORT	1	[486]	1h
Reserved	Reserved	177	[485:309]	-
CMDQ support	CMDQ_SUPPORT	1	[308]	1h
CMDQ depth	CMDQ_DEPTH	1	[307]	1Fh
Reserved	Reserved	1	[306]	-
Number of FW sectors correctly programmed	NUMBER_OF_FW_SECTORS_CORRECTLY_PROGRAMMED	4	[305:302]	0h
Vendor proprietary health report	VENDOR_PROPRIETARY_HEALTH_REPORT	32	[301:270]	0h

Device life time estimation type B	DEVICE_LIFE_TIME_EST_TYP_B	1	[269]	1h
Device life time estimation type A	DEVICE_LIFE_TIME_EST_TYP_A	1	[268]	1h
Pre EOL information	PRE_EOL_INFO	1	[267]	1h
Optimal read size	OPTIMAL_READ_SIZE	1	[266]	1h
Optimal write size	OPTIMAL_WRITE_SIZE	1	[265]	8h
Optimal trim unit size	OPTIMAL_TRIM_UNIT_SIZE	1	[264]	1h
Device version	DEVICE_VERSION	2	[263:262]	0h
Firmware version	FIRMWARE_VERSION	8	[261:254]	0h*
Power class for 200MHz, DDR at VCC=3.6V	PWR_CL_DDR_200_360	1	[253]	0h
Cache size	CACHE_SIZE	4	[252:249]	1024
Generic CMD6 timeout	GENERIC_CMD6_TIME	1	[248]	32h
Power off notification(long) timeout	POWER_OFF_LONG_TIME	1	[247]	28h
Background operations status	BKOPS_STATUS	1	[246]	0h
Number of correctly programmed sectors	CORRECTLY_PRG_SECTORS_NUM	4	[245:242]	0h
1st initialization time after partitioning	INI_TIMEOUT_AP	1	[241]	Ch
Cache Flushing Policy	CACHE_FLUSH_POLICY	1	[240]	1h
Power class for 52MHz, DDR at 3.6V	PWR_CL_DDR_52_360	1	[239]	0h
Power class for 52MHz, DDR at 1.95V	PWR_CL_DDR_52_195	1	[238]	0h
Power class for 200MHz at 3.6V	PWR_CL_200_195	1	[237]	0h
Power class for 200MHz, at 1.95V	PWR_CL_200_130	1	[236]	0h
Minimum Write Performance for 8bit at 52MHz in DDR mode	MIN_PERF_DDR_W_8_52	1	[235]	0h
Minimum Read Performance for 8bit at 52MHz in DDR mode	MIN_PERF_DDR_R_8_52	1	[234]	0h
Reserved	-	1	[233]	-

TRIM Multiplier	TRIM_MULT	1	[232]	11h- TLC 64/32GB
Secure Feature support	SEC_FEATURE_SUPPORT	1	[231]	55h
Secure Erase Multiplier	SEC_ERASE_MULT	1	[230]	F7h
Secure TRIM Multiplier	SEC_TRIM_MULT	1	[229]	F7h
Boot information	BOOT_INFO	1	[228]	7h
Reserved	-	1	[227]	0h
Boot partition size	BOOT_SIZE_MULTI	1	[226]	20h
Access size	ACC_SIZE	1	[225]	7h-TLC 32GB 8h- TLC 64GB
High-capacity erase unit size	HC_ERASE_GRP_SIZE	1	[224]	1h
High-capacity erase timeout	ERASE_TIMEOUT_MULT	1	[223]	11h- TLC 64/32GB
Reliable write sector count	REL_WR_SEC_C	1	[222]	1h
High-capacity write protect group size	HC_WP_GRP_SIZE	1	[221]	10h
Sleep current (VCC)	S_C_VCC	1	[220]	8h
Sleep current (VCCQ)	S_C_VCCQ	1	[219]	8h
Production state awareness Timeout	PRODUCTION_STATE_AWARENESS_TIMEOUT	1	[218]	17h
Sleep/awake timeout	S_A_TIMEOUT	1	[217]	15h
Sleep Notification timeout	SLEEP_NOTIFICATION_TIME	1	[216]	0Fh
Sector Count	SEC_COUNT	4	[215:212]	61145088- TLC 32GB  122290176- TLC 64GB
Security write protect information	SECURE_WP_INFO	1	[211]	1h
Minimum Write Performance for 8bit at 52MHz	MIN_PERF_W_8_52	1	[210]	8h

Minimum Read Performance for 8bit at 52MHz	MIN_PERF_R_8_52	1	[209]	8h
Minimum Write Performance for 8bit at 26MHz, for 4bit at 52MHz	MIN_PERF_W_8_26_4_52	1	[208]	8h
Minimum Read Performance for 8bit at 26MHz, for 4bit at 52MHz	MIN_PERF_R_8_26_4_52	1	[207]	8h
Minimum Write Performance for 4bit at 26MHz	MIN_PERF_W_4_26	1	[206]	8h
Minimum Read Performance for 4bit at 26MHz	MIN_PERF_R_4_26	1	[205]	8h
Reserved	-	1	[204]	0h
Power class for 26MHz at 3.6V 1 R	PWR_CL_26_360	1	[203]	0h
Power class for 52MHz at 3.6V 1 R	PWR_CL_52_360	1	[202]	0h
Power class for 26MHz at 1.95V 1 R	PWR_CL_26_195	1	[201]	0h
Power class for 52MHz at 1.95V 1 R	PWR_CL_52_195	1	[200]	0h
Partition switching timing	PARTITION_SWITCH_TIME	1	[199]	FFh
Out-of-interrupt busy timing	OUT_OF_INTERRUPT_TIME	1	[198]	FFh
I/O Driver Strength	DRIVER_STRENGTH	1	[197]	1Fh
Device type	DEVICE_TYPE	1	[196]	57h
Reserved	-	1	[195]	0h
CSD structure version	CSD_STRUCTURE	1	[194]	2h
Reserved	-	1	[193]	0h
Extended CSD revision	EXT_CSD_REV	1	[192]	8h
Command set	CMD_SET	1	[191]	0h
Reserved	-	1	[190]	0h
Command set revision	CMD_SET_REV	1	[189]	0h
Reserved	-	1	[188]	0h
Power class	POWER_CLASS	1	[187]	0h
Reserved	-	1	[186]	0h

High-speed interface timing	HS_TIMING	1	[185]	1h (note 3)
Strobe support	STROBE_SUPPORT	1	[184]	1h
Bus width mode	BUS_WIDTH	1	[183]	2h (note 4)
Reserved	–	1	[182]	0h
Erased memory content	ERASED_MEM_CONT	1	[181]	0h
Reserved	–	1	[180]	0h
Partition configuration	PARTITION_CONFIG	1	[179]	0h
Boot config protection	BOOT_CONFIG_PROT	1	[178]	0h
Boot bus Conditions	BOOT_BUS_CONDITIONS	1	[177]	0h
Reserved	–	1	[176]	0h
High-density erase group definition	ERASE_GROUP_DEF	1	[175]	0h
Boot write protection status registers	BOOT_WP_STATUS	1	[174]	0h
Boot area write protection register	BOOT_WP	1	[173]	0h
Reserved	–	1	[172]	0h
User area write protection register	USER_WP	1	[171]	0h
Reserved	–	1	[170]	0h
FW configuration	FW_CONFIG	1	[169]	0h
RPMB Size	RPMB_SIZE_MULT	1	[168]	20h
Write reliability setting register	WR_REL_SET	1	[167]	0h
Write reliability parameter register	WR_REL_PARAM	1	[166]	15h
Start Sanitize operation	SANITIZE_START	1	[165]	0h
Manually start background operations	BKOPS_START	1	[164]	0h
Enable background operations handshake	BKOPS_EN	1	[163]	0h
H/W reset function	RST_n_FUNCTION	1	[162]	0h
HPI management	HPI_MGMT	1	[161]	0h
Partitioning Support	PARTITIONING_SUPPORT	1	[160]	7h

Max Enhanced Area Size	MAX_ENH_SIZE_MULT	3	[159:157]	1244-TLC 32GB  2488-TLC 64GB
Partitions attribute	PARTITIONS_ATTRIBUTE	1	[156]	0h
Partitioning Setting	PARTITION_SETTING_COMPLETED	1	[155]	0h
General Purpose Partition Size	GP_SIZE_MULT 4	3	[154:152]	0h
General Purpose Partition Size	GP_SIZE_MULT3	3	[151:149]	0h
General Purpose Partition Size	GP_SIZE_MULT2	3	[148:146]	0h
General Purpose Partition Size	GP_SIZE_MULT1	3	[145:143]	0h
Enhanced User Data Area Size	ENH_SIZE_MULT	3	[142:140]	0h
Enhanced User Data Start Address	ENH_START_ADDR	4	[139:136]	0h
Reserved	-	1	[135]	0h
Bad Block Management mode	SEC_BAD_BLK_MGMNT	1	[134]	0h
Production state awareness	PRODUCTION_STATE_AWARENESS	1	[133]	0h
Package Case Temperature is controlled	TCASE_SUPPORT	1	[132]	0h
Periodic Wake-up	PERIODIC_WAKEUP	1	[131]	0h
Program CID/CSD in DDR mode support	PROGRAM_CID_CSD_DDR_SUPPORT	1	[130]	1h
Reserved	-	2	[129:128]	0h
Vendor Specific Fields	VENDOR_SPECIFIC_FIELD	61	[127:67]	-
Error code	ERROR_CODE	2	[66:65]	0h
Error type	ERROR_TYPE	1	[64]	0h
Native sector size	NATIVE_SECTOR_SIZE	1	[63]	0h
Sector size emulation	USE_NATIVE_SECTOR	1	[62]	0h
Sector size	DATA_SECTOR_SIZE	1	[61]	0h
1st initialization after disabling sector size emulation	INI_TIMEOUT_EMU	1	[60]	0h
Class 6 commands control	CLASS_6_CTRL	1	[59]	0h

Number of addressed group to be Released	DYNCAP_NEEDED	1	[58]	0h
Exception events control	EXCEPTION_EVENTS_CTRL	2	[57:56]	0h
Exception events status	EXCEPTION_EVENTS_STATUS	2	[55:54]	0h
Extended Partitions Attribute	EXT_PARTITIONS_ATTRIBUTE	2	[53:52]	0h
Context configuration	CONTEXT_CONF	15	[51:37]	-
Packed command status	PACKED_COMMAND_STATUS	1	[36]	0h
Packed command failure index	PACKED_FAILURE_INDEX	1	[35]	0h
Power Off Notification	POWER_OFF_NOTIFICATION	1	[34]	0h
Control to turn the Cache ON/OFF	CACHE_CTRL	1	[33]	0h
Flushing of the cache	FLUSH_CACHE	1	[32]	0h
Barrier control	BARRIER_CTRL	1	[31]	0h
Mode config	MODE_CONFIG	1	[30:30]	0h
Mode operation codes	MODE_OPERATION_CODES	1	[29:29]	0h
Reserved	Reserved	2	[28:27]	0h
FFU status	FFU_STATUS	1	[26:26]	0h
Per loading data size	PRE_LOADING_DATA_SIZE	4	[25:22]	0h
Max pre loading data size	MAX_PRE_LOADING_DATA_SIZE	4	[21:18]	61145088-TLC 32GB 122290176-TLC 64GB
Product state awareness enablement	PRODUCT_STATE_AWARENESS_ENABLEMENT	1	[17:17]	1h
Secure removal type	SECURE_REMOVAL_TYPE	1	[16:16]	39h
Command Queue Mode enable	CMQ_MODE_EN	1	[15:15]	0h
Reserved	Reserved	15	[14:0]	-

Note1 : Reserved bits should read as "0."

Note2 : Obsolete values should be don't care.

Note3 : This field is 0 after power-on, H/W reset or software reset, thus selecting the backwards compatibility interface timing for the Device. If the host sets 1 to this field, the Device changes its timing to high speed interface timing (see Section 10.6.1 of JESD84-B50). If the host sets value 2 the Device changes its timing to HS200 interface timing (see Section 10.8.1 of JESD84-B50), If the host sets HS\_TIMING[3:0] to 0x3, the device changes its timing to HS400 interface timing (see 10.10).

Note4 : It is set to '0' (1 bit data bus) after power up and can be changed by a SWITCH command.

Note5: \* Changed by Firmware release note

## 6. Package Connections

### 6.1. Package Mechanical

#### 6.1.1. 11.5 x 13.0 x 1mm 153 Ball Package

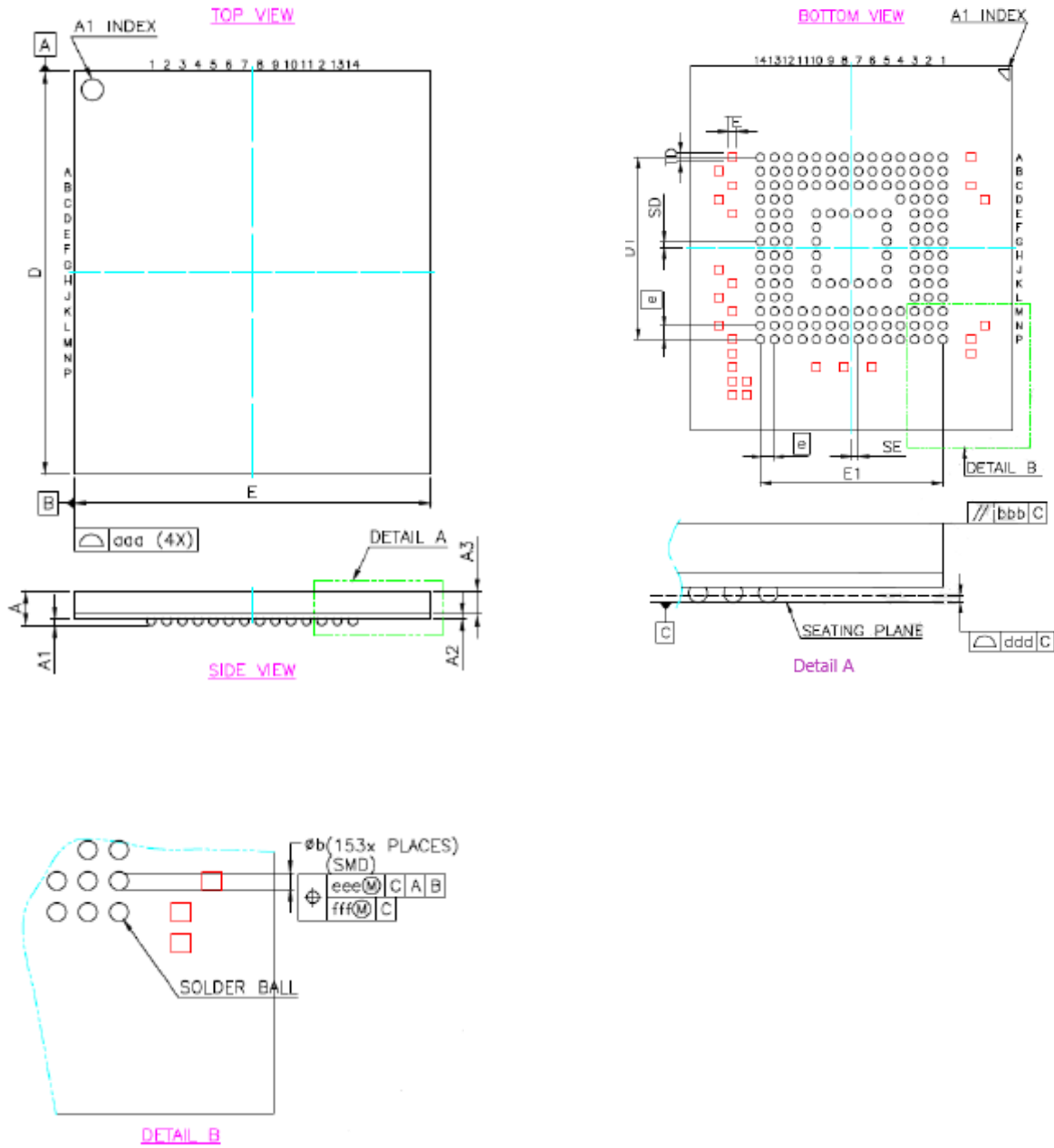



	SYM	DIMENSION (MM)		
		MIN.	NOM.	MAX.
Total Thickness	A	0.80	0.95	1.00
Stand Off	A1	0.17	0.22	0.27
Substrate Thickness	A2	-	0.13	-
Mold Thickness	A3	-	0.60	-
Ball Width	b	0.25	0.30	0.35
Body Size	D	12.90	13.00	13.10
Ball Diameter (Pre-Reflow)		0.30		
Ball Opening		0.275		
Edge Ball Center to Center	D1	6.50 BSC		
Body Size	E	11.40	11.50	11.60
Edge Ball Center to Center	E1	6.50 BSC		
Body Center to Center	SD	0.25 BSC		
	SE	0.25 BSC		
JEDEC (REF)		MO-276 (REF)		
Ball Pitch		0.50 BSC		
Ball Count	N	153		
Test Pad	TE	0.25	0.30	0.35
Test Pad	TD	0.25	0.30	0.35
Package Edge Tolerance	aaa	0.15		
Mold Flatness	bbb	0.20		
Coplanarity	ddd	0.08		
Ball Offset (Package)	eee	0.15		
Ball Offset (Ball)	ff	0.05		

Note: Controlling Dimension: Millimeter

## 7. Ball Assignments

### 7.1. 153 Ball Package

	1	2	3	4	5	6	7	8	9	10	11	12	13	14		
A	NC	NC	DAT0	DAT1	DAT2	VSS	RFU	NC	NC	NC	NC	NC	NC	NC	A	
B	NC	DAT3	DAT4	DAT5	DAT6	DAT7	NC	NC	NC	NC	NC	NC	NC	NC	B	
C	NC	VDDi	NC	VSSQ	NC	VCCQ	NC	NC	NC	NC	NC	NC	NC	NC	C	
D	NC	NC	NC	NC								NC	NC	NC	D	
E	NC	NC	NC				RFU	VCC	VSS	VSF	VSF	VSF	NC	NC	NC	E
F	NC	NC	NC				VCC					VSF	NC	NC	NC	F
G	NC	NC	RFU				VSS					VSF	NC	NC	NC	G
H	NC	NC	NC				DS					VSS	NC	NC	NC	H
J	NC	NC	NC				VSS					VCC	NC	NC	NC	J
K	NC	NC	NC				RST_n	RFU	RFU	VSS	VCC	VSF	NC	NC	NC	K
L	NC	NC	NC								NC	NC	NC	L		
M	NC	NC	NC	VCCQ	CMD	CLK	NC	NC	NC	NC	NC	NC	NC	NC	M	
N	NC	VSSQ	NC	VCCQ	VSSQ	NC	NC	NC	NC	NC	NC	NC	NC	NC	N	
P	NC	NC	VCCQ	VSSQ	VCCQ	VSSQ	RFU	NC	NC	VSF	NC	NC	NC	NC	P	
	1	2	3	4	5	6	7	8	9	10	11	12	13	14		

153 ball assignment

## 8. Signal Description

PIN	Description
CLK	Clock Signal.
CMD	Command Signal.
DS	Data Strobe Signal , Used in HS400 mode.
DAT0~7	Data Bus.
RST_N	Hardware Reset Signal.
VCC	Supply voltage for controller and Flash memory power.
VCCQ	Supply voltage for controller and Flash memory IO power.
VDDi	Connect capacitor from VDDi to GND for stabilize internal power.
VSS	Supply voltage ground for controller and Flash memory. Can be short with VSSQ.
VSSQ	Supply voltage ground for controller and IO Flash memory. Can be short with VSSQ.
NC	In eMMC chip is no connect. Left it floating.
RFU	Reserved for future use. Left it floating for future use.
VSF	Vendor Specific Function. Left it floating.

Some balls could be floated to achieve eMMC 4.5 force conversion.

- A6 VSS → Float NC
- J5 VSS → Float NC
- H5 DS → Float NC

## 9. Ordering Information

Capacity/Type	Package Type	Delkin Part Number	Packaging
32GB	153 Ball 11.5x13x1.0	EM32FQYHY-BA000-2	Trays  1520 per box 10 trays of 152 MOQ 1 box
64GB		EM64FQYHY-BA000-2	

**WARNING:** This product may contain chemicals known to the State of California to cause cancer, birth defects, or other reproductive harm. For more information go to [www.p65warnings.ca.gov](http://www.p65warnings.ca.gov).