

4

3

2

1

REVISIONS

ZONE	REV.	DESCRIPTION	DATE	APPROVED
	A	RELEASED FOR QUOTE	3/8/2021	DMM

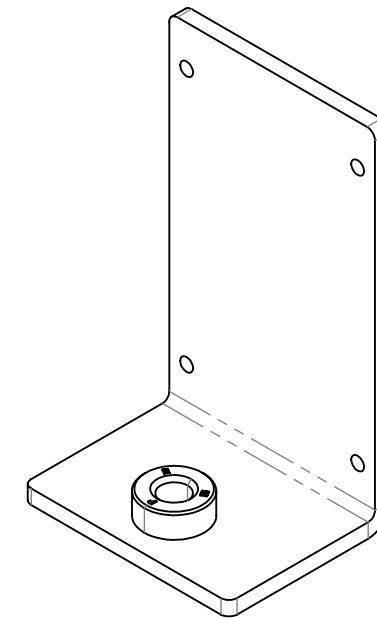
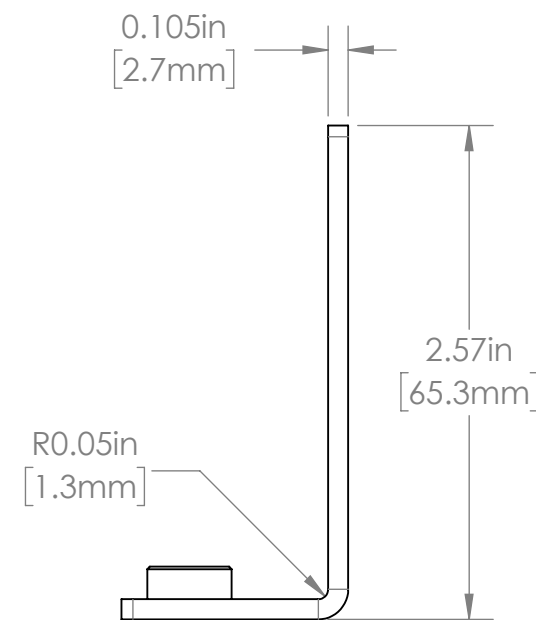
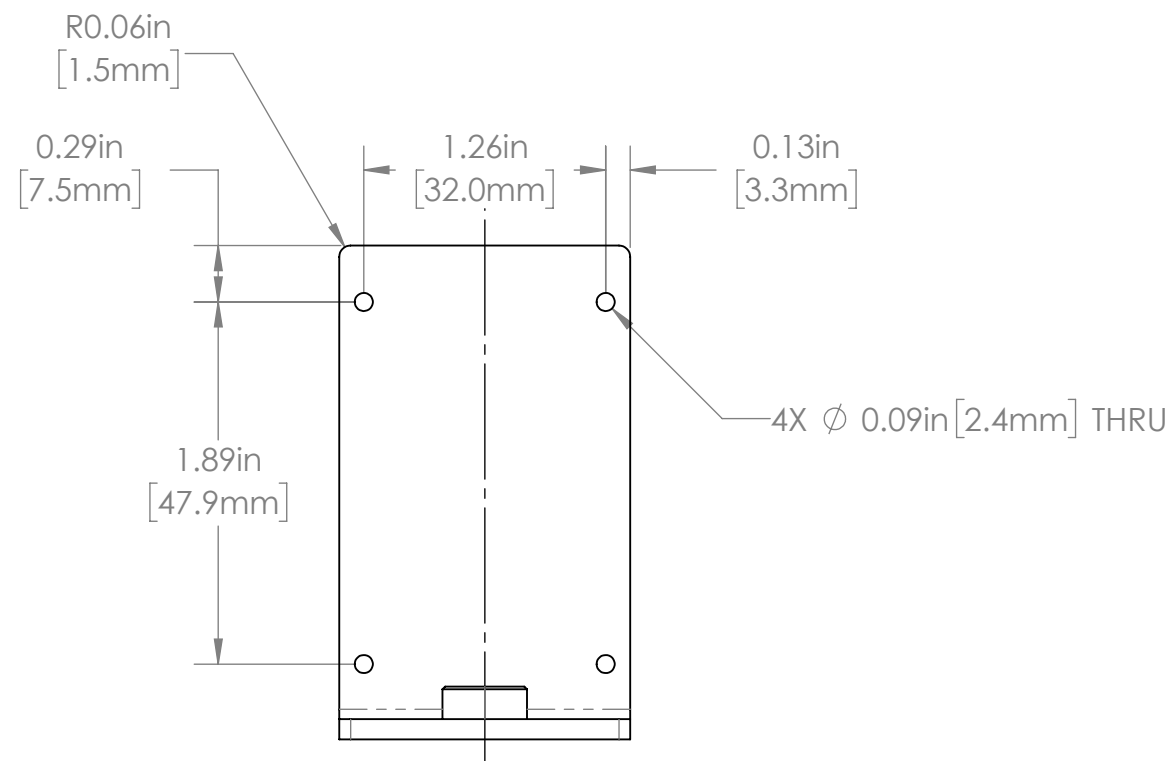
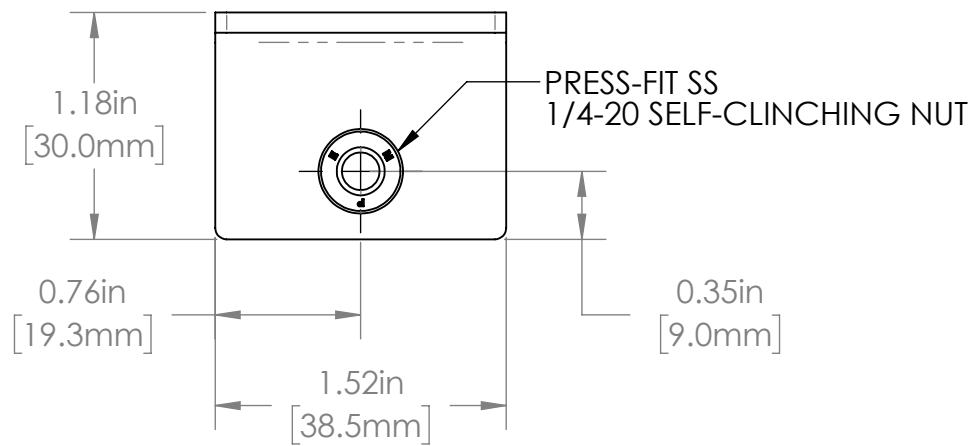

TOLERANCES UNLESS OTHERWISE SPECIFIED

MACHINING		SHEET METAL	
X.X	0.0250"	<u>HOLE TO HOLE (SAME SURFACE)</u>	
X.XX	0.0100"	X.X	0.030"
X.XXX	0.0050"	X.XX	0.010"
X.XXXX	0.0005"	X.XXX	0.005"
ANGULAR	0.5°	<u>HOLE TO FOLDED EDGE</u>	
DEBURR ALL		X.X	0.035"
		X.XX	0.025"
		X.XXX	0.015"
		<u>FOLD TO FOLD</u>	
		X.X	0.045"
		X.XX	0.035"
		X.XXX	0.020"
		ANGULAR 1.0°	

ALL WEIGHTS ARE IN POUNDS

THIS PRINT IS THE PROPERTY OF ALLISON PARK GROUP. THE INFORMATION CONTAINED HEREIN IS CONFIDENTIAL. IT IS NOT TRANSFERABLE. IT IS FURNISHED WITH THE CLEAR UNDERSTANDING THAT IT IS NOT TO BE TRACED, REPRODUCED OR USED IN ANY PROCESS OF MANUFACTURING WITHOUT WRITTEN PERMISSION FROM THE OWNER AND IS RETURNABLE UPON DEMAND. ANY INFRINGEMENT UPON THE PATENT RIGHTS SHOWN HEREIN, WHETHER IN PART OR WHOLE, WILL BE PROSECUTED.

AS PART OF OUR POLICY OF CONTINUING DEVELOPMENT, ALLISON PARK GROUP RESERVES THE RIGHT TO ALTER SPECIFICATIONS WITHOUT PRIOR NOTICE.

Pixelink
AMETEK

1900 City Park Drive, Suite 410
Ottawa, ON, K1J 1A3, Canada
Phone +1 (343) 339-5261
pixelink.com

DESCRIPTION:
**RIGHT ANGLE ADAPTER FOR
PIXELINK PL-D**

MATERIAL:
304 STAINLESS STEEL

FINISH:
BURNISHED

DRAWN BY: TWD	DATE: 3/8/2021	SCALE: 1:1	SHT-SIZE: B	APPROX. WEIGHT: 0.1630
CHECKED BY: DMM	DATE: 3/8/2021	PART NUMBER: PL-MH-07		REVISION: A

Sheet 1 of 1

4

3

2

1