

May.1.2023 Copyright 2023 HIROSE ELECTRIC CO., LTD. All Rights Reserved.
In case of consideration for using Automotive equipment / device which demand high reliability, kindly contact our sales window correspondents.

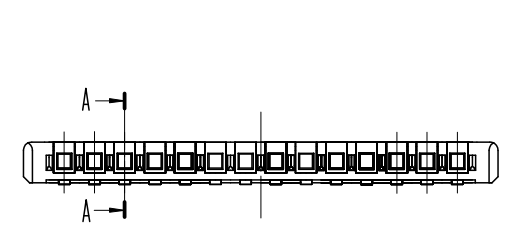

4 RECOMMENDED PATTERN

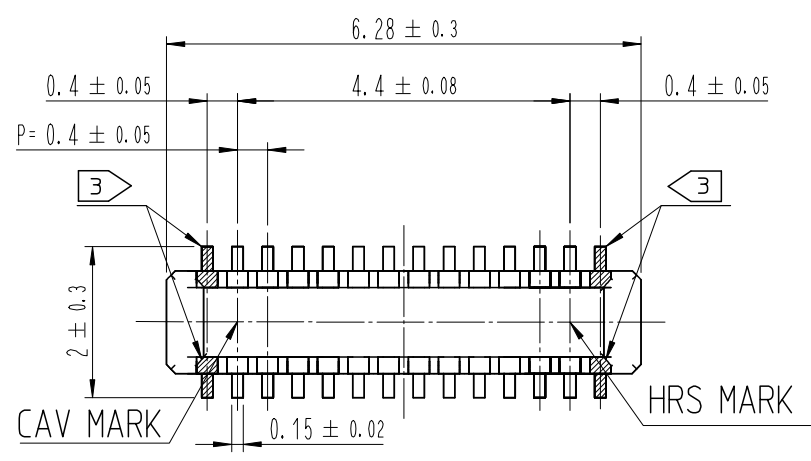
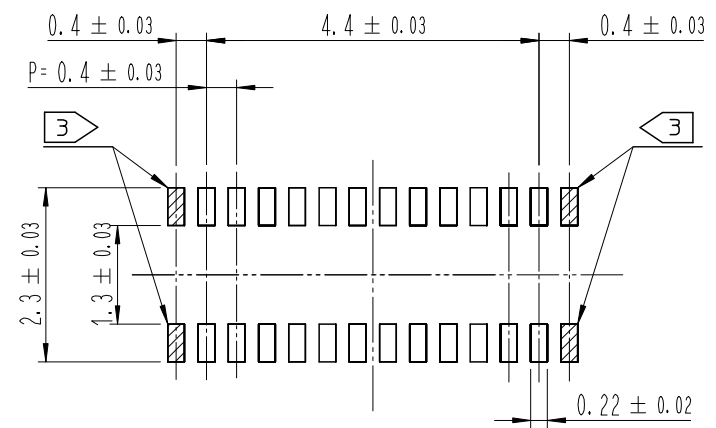

4 RECOMMENDED SOLDER PASTE: THICKNESS 100 μm

- NOTE
- 1. ALL LEAD CO-PLANARITY SHALL BE 0.08mm MAX.
 - 2. CONTACT PLATING SPECIFICATIONS.
CONTACT AREA : GOLD 0.05 μm MIN.
SMT LEAD : GOLD 0.05 μm MIN.
UNDER PLATING : NICKEL 1 μm MIN.
(SURFACE : SEALING)
 - 3. EACH CONTACTS 4 CORNERS ARE PROVIDED FOR METAL FITTINGS.
(NOT FOR ELECTRICAL CONNECTION)
 - 4. PLEASE CONTACT US IN CASE YOU WILL MAKE DIFFERENT SETTINGS FROM OUR RECOMMENDATION.

HRS DRAWING FOR REFERENCE

DRAWING FOR REFERENCE
This is subject to change without notice

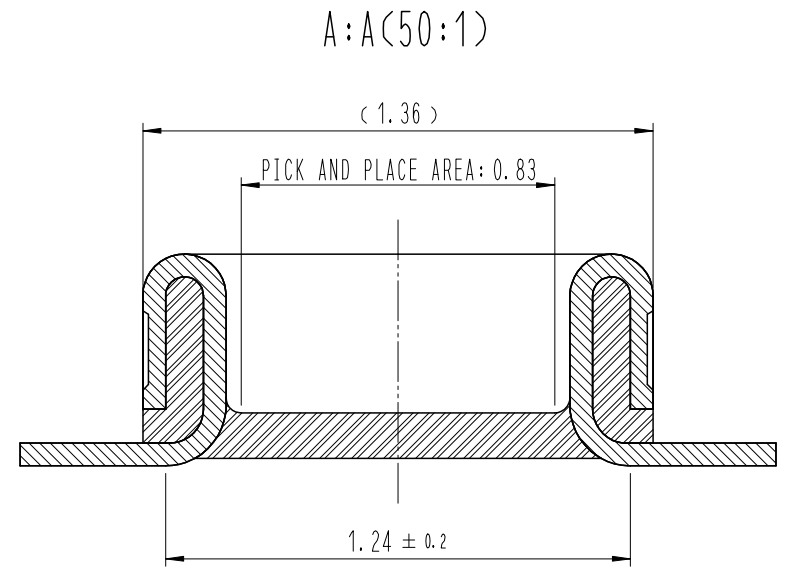
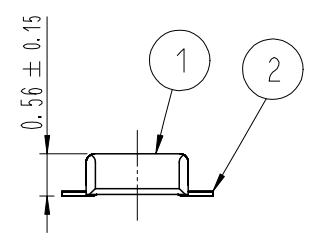

ENGAGEMENT FIGURE (50:1)

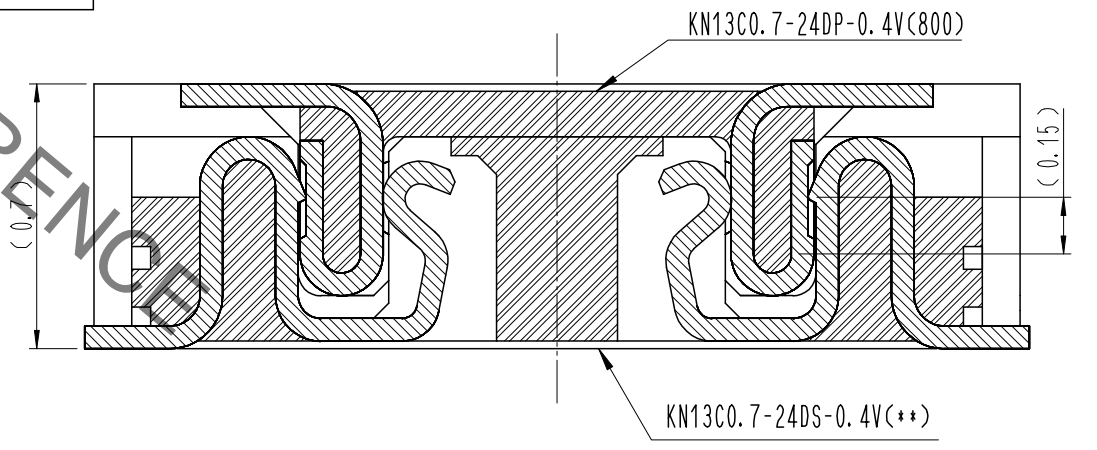

COUNT	DESCRIPTION OF REVISIONS	B	Y	CHKD	DATE	COUNT	DESCRIPTION OF REVISIONS	B	Y	CHKD	DATE
△						△					
△						△					
△						△					

3	PS	CLEAR (EMBOSSED CARRIER TAPE)				5	PS	BLACK (PLASTIC REEL)		
2	COPPER ALLOY	2				4	POLYESTER	CLEAR (COVER TAPE)		
1	LCP	UL94 V-0, BLACK								
NO.	MATERIAL	FINISH, REMARKS	NO.	MATERIAL	FINISH, REMARKS					
REMARKS						DRAWN	DESIGNED	CHECKED	APPROVED	RELEASED
						S. H. JUNG	S. H. JUNG	H. W. JO	T. S. KANG	16.11.30
						16.11.30	16.11.30	16.11.30	16.11.30	16.11.30
CODE NO. (OLD)	DRAWING NO. EDC3-*****		PART NO. KN13CO.7-24DP-0.4V(800)							
SCALE 10:1	HRS HIROSE KOREA CO., LTD.		CODE NO. CL 66**-*****-800							
UNITS mm						1/2				

May.1.2023 Copyright 2023 HIROSE ELECTRIC CO., LTD. All Rights Reserved.
In case of consideration for using Automotive equipment / device which demand high reliability, kindly contact our sales window correspondents.

EMBOSED CARRIER TAPE PACKAGING (5:1)

C-C (5:1)

STYLE AND DIMENSION OF REEL (FREE)

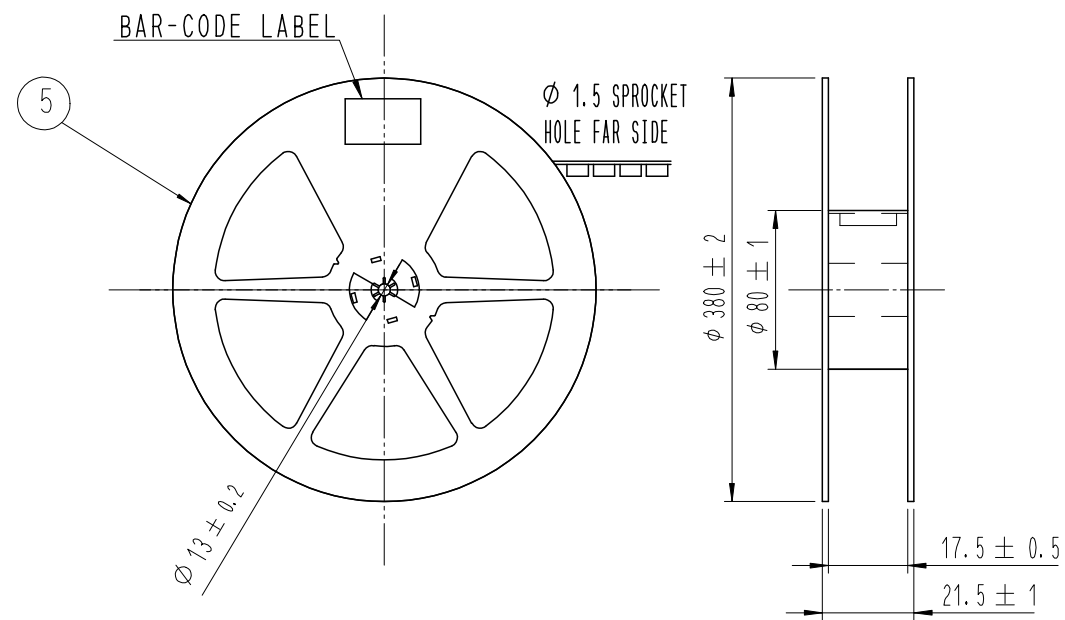
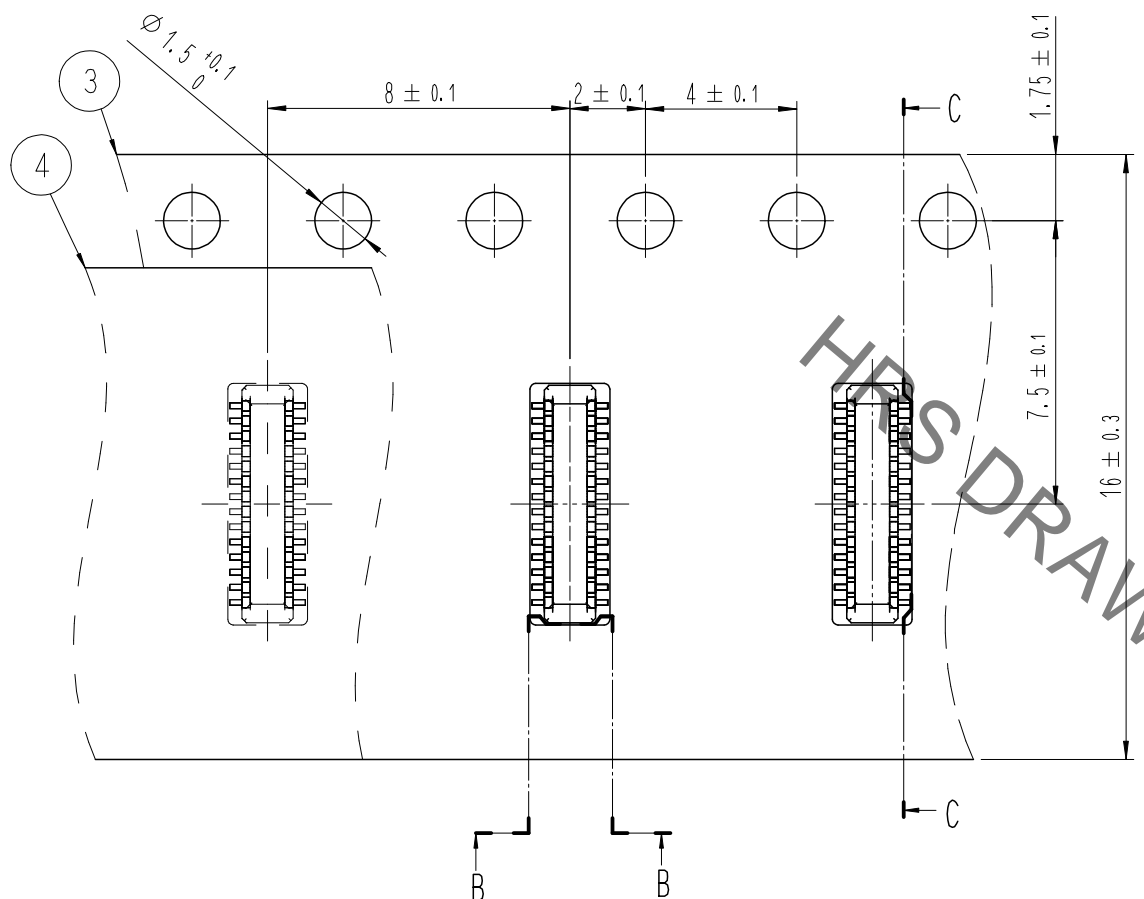

B-B (5:1) DIRECTION OF UNREELING →

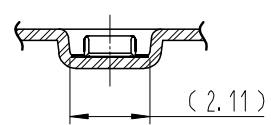

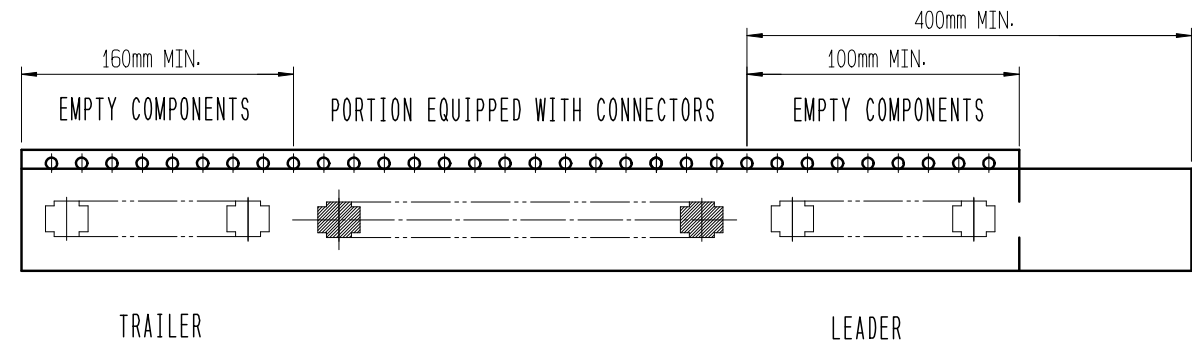

7 TAPING(FREE)



DETAIL OF PART No. LABEL

CUSTOMER NAME	#####
PART NO.	모델명 : KN13C0.7-24DP-0.4V(800)
CUSTOMER CODE NO.	자재코드 :
QUANTITY	수량 : 8000 pcs
LOT NO.	LOT 번호 : *****-**-***
	KN13C0.7-24DP-0.4V(800)
	

5 . PER REEL 8,000 CONNECTORS.
6 . THE DIMENSIONS IN PARENTHESES ARE FOR REFERENCE.
7 → REFER TO JIS C 0806, IEC-60286-3 (PACKAGING OF COMPONENTS FOR AUTOMATIC HANDLING)

 SCALE 10:1 UNITS mm	DRAWING NO.	EDC3-*****	PART NO.	KN13C0.7-24DP-0.4V(800)
	 HIROSE KOREA CO., LTD.		CODE NO.	CL 66**-*****-800