

May.1.2023 Copyright 2023 HIROSE ELECTRIC CO., LTD. All Rights Reserved.  
In case of consideration for using Automotive equipment / device which demand high reliability, kindly contact our sales window correspondents.

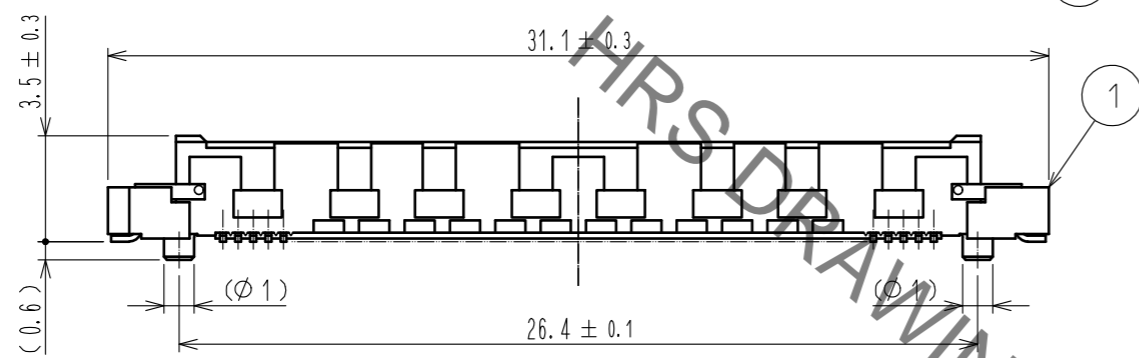

RECOMMENDED LAND PATTERN DIMENSION OF PCB  
(RECOMMENDED METAL MASK THICKNESS : 0.15mm)

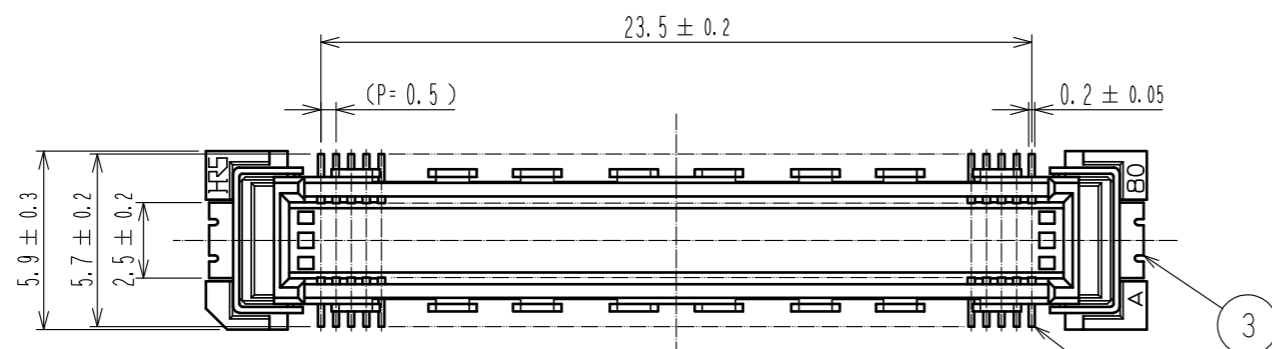
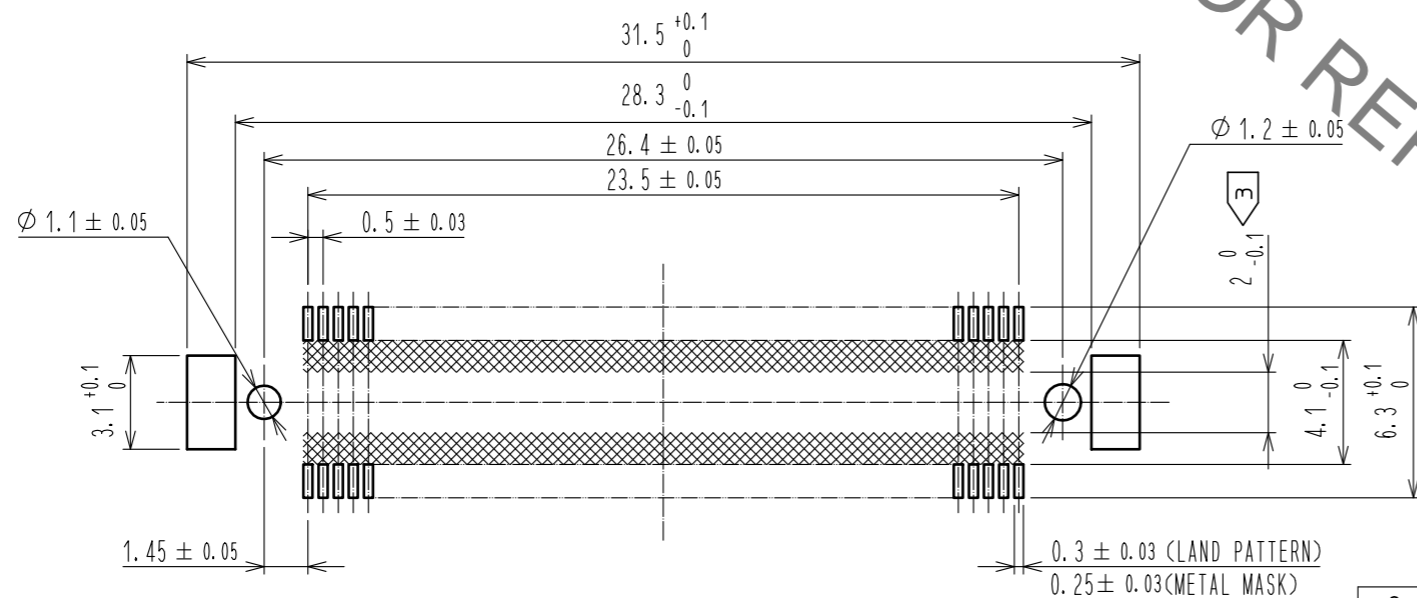

- NOTES
- 1 SMT LEAD-COPLANARITY : 0.1 MAX.
  - 2 THIS PRODUCT HAS NO POLARITY TO PATTERN FOR MOUNTING.
  - 3 MAKE SURE WIDTH OF PATTERN IS WITHIN THAT OF LAND, OR LEAD MAY TOUCH PATTERN. (THIS APPLIES TO HATCHED AREA.)
  - 4 EMBOSS CARRIER TAPE PACKAGE IS APPLIED ON THIS PRODUCT. PLEASE REFER TO THE SHEET 2/2 FOR THE DETAILS.
  - 5 THE DIMENSIONS IN PARENTHESES ARE FOR REFERENCE.

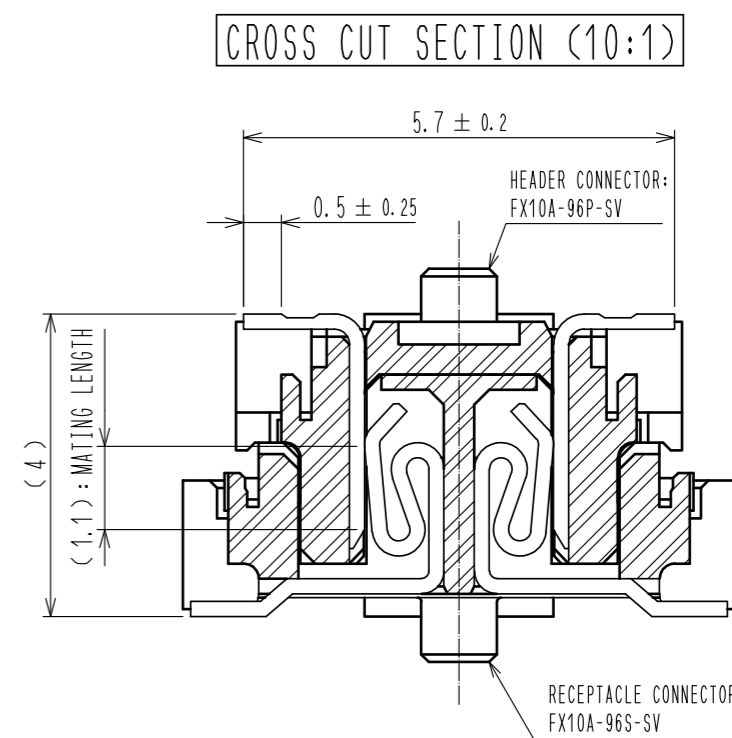
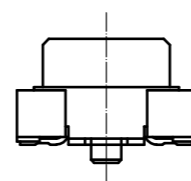

3	PHOSPHOR BRONZE	TIN-PLATING					
		CONTACT AREA : GOLD 0.1µm min.					
2	PHOSPHOR BRONZE	LEAD AREA : TIN-PLATING 1µm min.					
		UNDER PLATING : NICKL 1µm min.	5	POLYESTER	TOP COVER TAPE		
1	LCP	BEIGE	4	POLYSTYRENE	EMBOSSED CARRIER TAPE		
NO.	MATERIAL	FINISH . REMARKS	NO.	MATERIAL	FINISH . REMARKS		
UNITS	mm	SCALE	4 : 1	COUNT	1	DESCRIPTION OF REVISIONS	DIS-F-00015196
		DESIGNED	SY. KUDO	CHECKED	HT. YAMAGUCHI	DATE	20220902
APPROVED : HT. YAMAGUCHI			20100729	DRAWING NO.		EDC-151952-91-21	
CHECKED : HT. YAMAGUCHI			20100729	PART NO.		FX10A-96P-SV(91)	
DESIGNED : SY. KAMIGA			20100729	CODE NO.		CL0570-0041-0-91	
DRAWN : HK. SUNADORI			20100728			1/2	

May.1.2023 Copyright 2023 HIROSE ELECTRIC CO., LTD. All Rights Reserved.  
In case of consideration for using Automotive equipment / device which demand high reliability, kindly contact our sales window correspondents.

# DRAWING FOR PACKING(2:1)

REELED DIMENSION (Free)

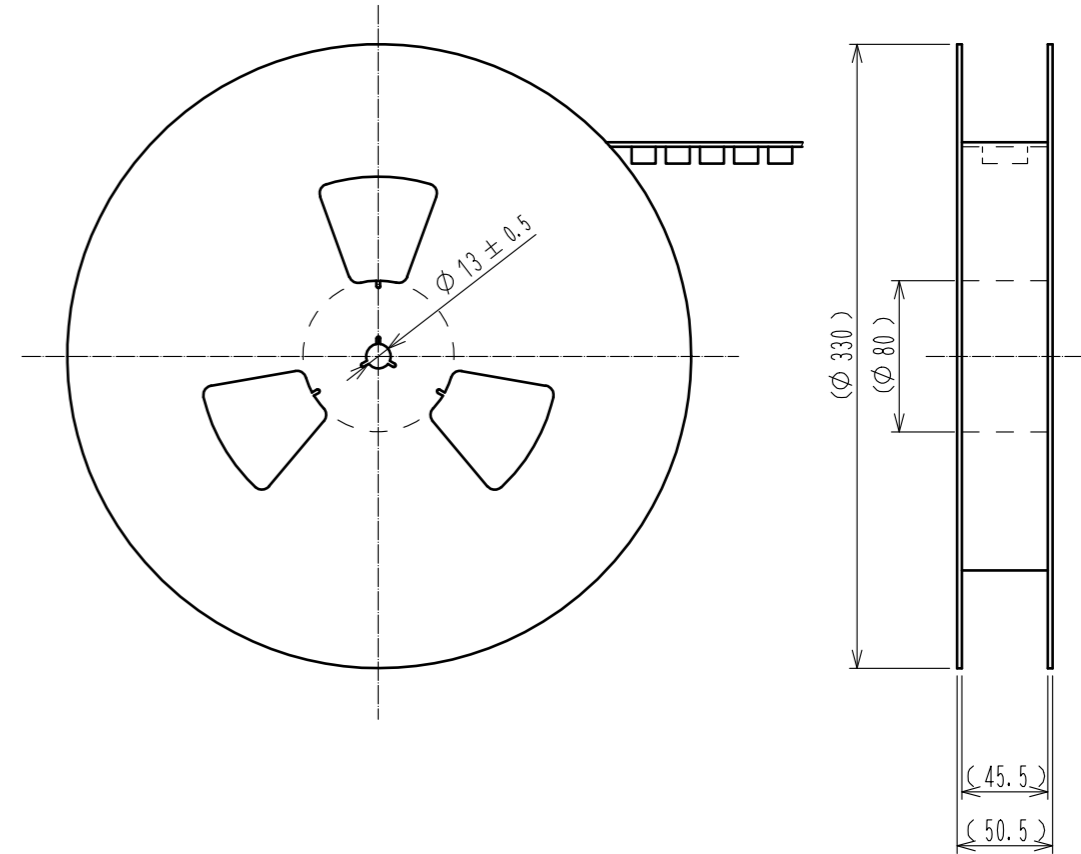
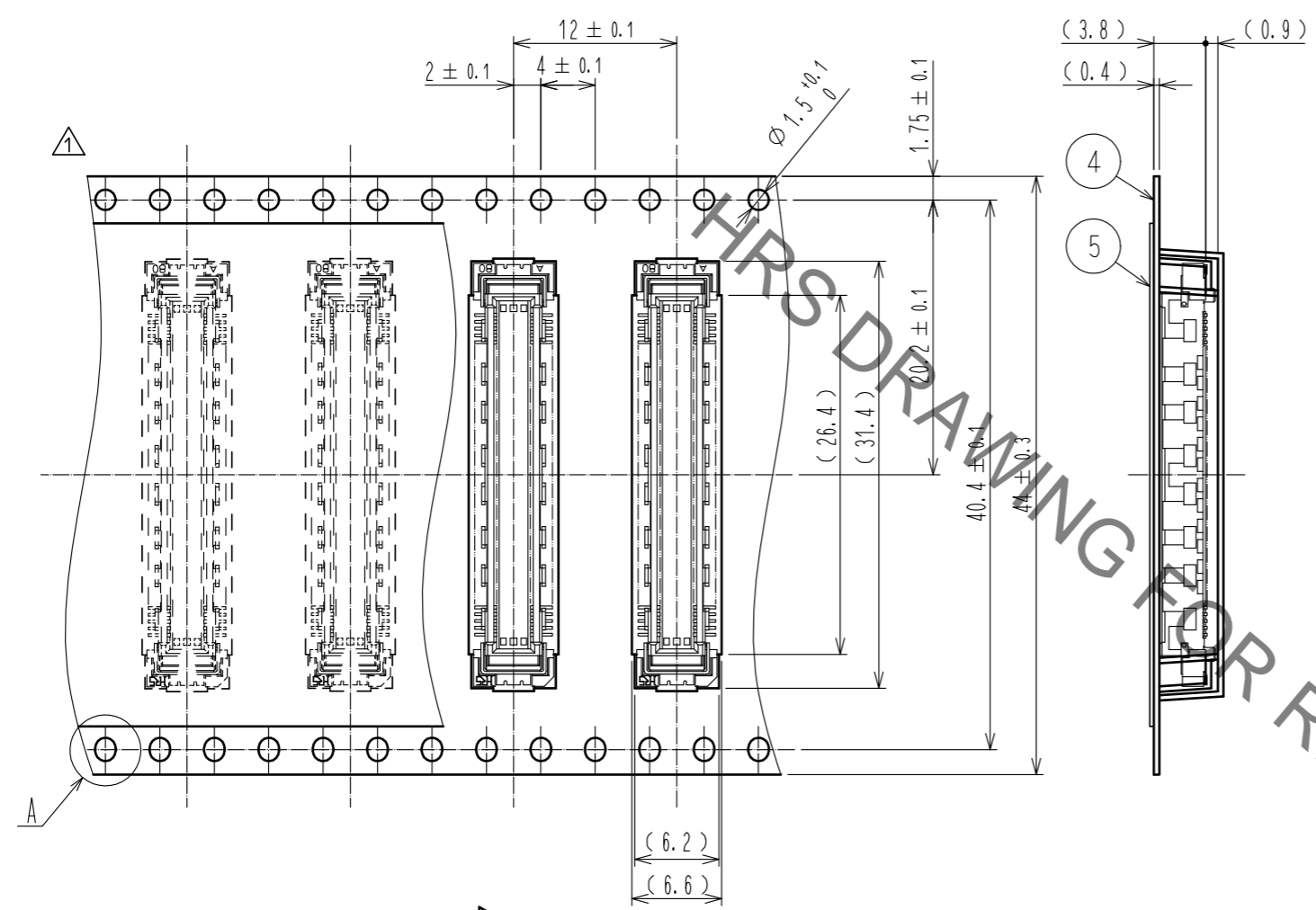

THE DIRECTION OF PULLING OUT →

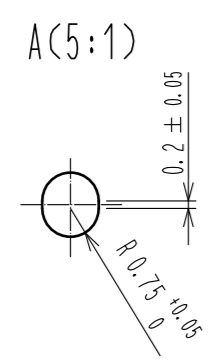

- NOTES
- 6 1 REEL : 1000 CONNECTORS.
  - 7 MINIMUM 10 COMPARTMENTS FROM BOTH REEL ENDS REMAIN EMPTY.
  - 8 THIS PRODUCT HAS NO POLARITY TO TAPE AND REEL PACKAGING.
  - 9 THE DIMENSIONS IN PARENTHESSES ARE FOR REFERENCE.

<b>HRS</b>	DRAWING NO.	EDC-151952-91-21	2/2
	PART NO.	FX10A-96P-SV(91)	
	CODE NO.	CL0570-0041-0-91	