

RAA2900014H12HPD

R07DS1266EJ0100

Rev.1.00

INTELLIGENT POWER DEVICE

Jun 17, 2015

1. Overview

1.1 Description

RAA290001 is designed for 2 Wheeler Flasher driver with double frequency flashing in low load current condition.

1.2 Features

- High side driver
- Low on-state resistance
- Small package; TO252-3
- Short circuit protection
 - Over temperature protection with current limitation control
- Built-in auto flashing operation with only one external capacitor
- Built-in double frequency flashing in low load condition
- Active clamp operation at inductive load switch off
- AEC Qualified
- RoHS compliant

1.3 Application

- 2 Wheeler Flasher bulb switching

Note: The information contained in this document is the one that was obtained when the document was issued, and may be subject to change.

2. Ordering Information

Part No.	Lead plating	Packing	Package
RAA2900014H12HPD	Pure Sn	Tape 2500pcs /reel	TO252 (MP-3ZP)

3. Specification

3.1 Block Diagram

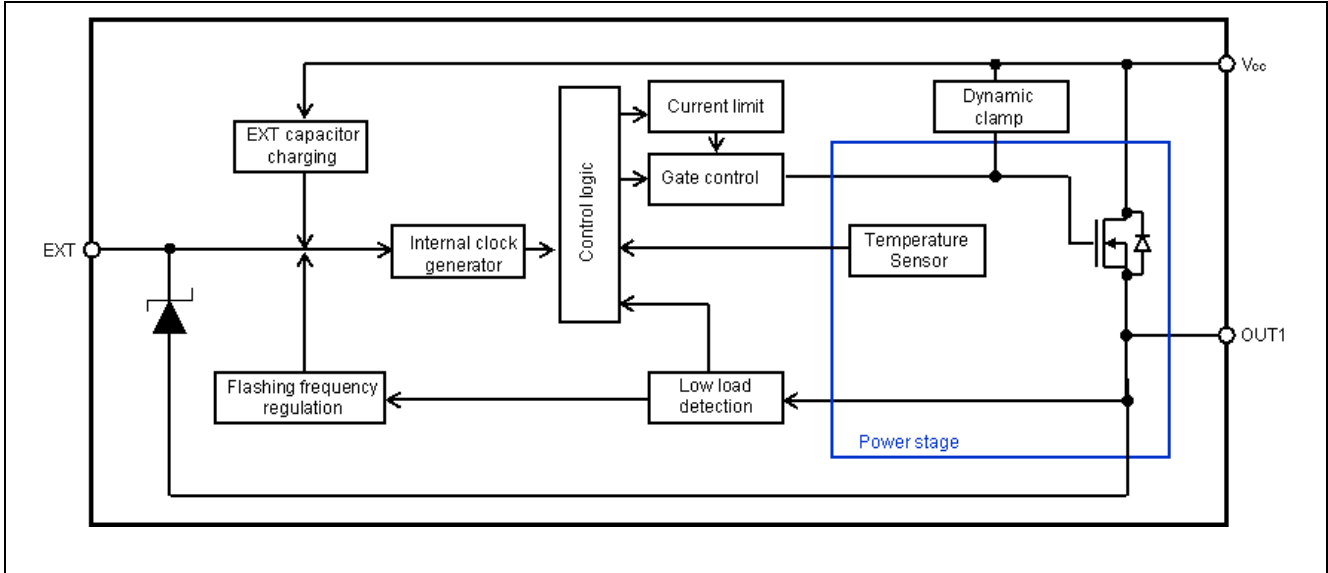

3.2 Current and Voltage definition

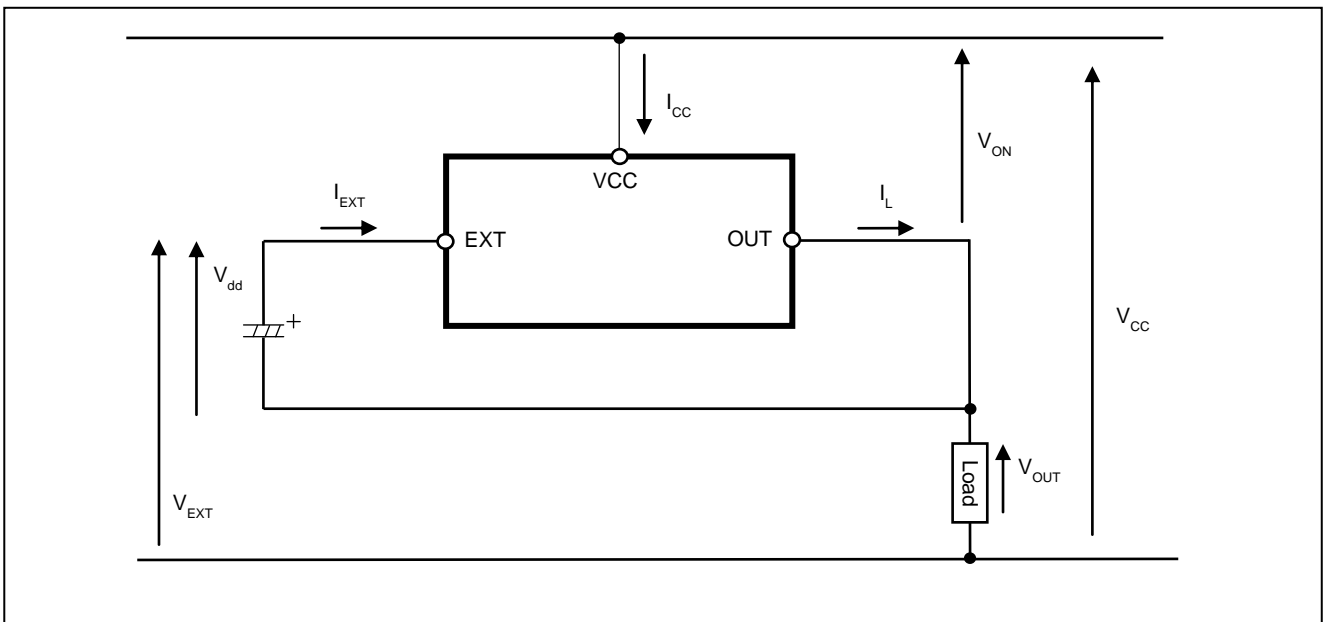

3.3 Pin Configuration

Pin No.	Terminal Name
1	EXT
2/4	VCC
3	OUT



Pin function

Terminal Name	Pin function	Recommended connection
EXT	An external capacitor is connected between EXT pin and OUT pin. This capacitor stores power supply to the device during on-state and sets the flashing frequency.	Connected to OUT pin with 220uF capacitor
VCC	Positive power supply for logic supply as well as output power supply	
OUT	Protected high-side power output channel	

3.4 Absolute Maximum Ratings

Ta=25degreeC, unless other specified

Parameter	Symbol	Rating	Unit	Test Condition		
Vcc Voltage	V _{CC}	28	V			
Vcc Voltage at reverse battery condition	-V _{CC}	-16	V	RL=Nomimal load, Refer 3.8.4, t<2min		
Output Drain to Source Voltage	V _{DSS}	42	V	RL=Nomimal load, Refer 3.8.4, t = 200 ms		
Load Current	I _L	Self limited	A			
OUT Reverse Current at reverse battery condition	-I _L	-5	A	t<2min		
Total power dissipation for whole device (DC)	P _D	1.8	W	Ta=85degreeC, Device on 50mmx50mmx1.5mm epoxy PCB FR4 with 6 cm2 of 70 um copper area		
Voltage between EXT and OUT	V _{dd}	6.5	V			
Channel Temperature	T _{ch}	-40 to +150	degreeC			
Storage Temperature	T _{stg}	-55 to +150	degreeC			
ESD susceptibility	V _{ESD}	2000	V	HBM	AEC-Q100-002 std. R=1.5kohm, C=100pF	All pin
		4000			IEC61000-4-2 std. R=330ohm, C=150pF, 100nF at VCC and OUT	VCC, OUT
		200	V	MM	AEC-Q100-003 std. R=0ohm, C=200pF	

3.5 Recommended Operation Condition

Parameter	Symbol	Min	Typ	Max	Unit	Test Condition
Ambient temperature	Ta	-20		85	degreeC	
Power supply voltage	V _{CC}	9		16	V	

3.6 Thermal Characteristics

Parameter	Symbol	Min	Typ	Max	Unit	Test Condition
Thermal characteristics	Rth(ch-a)		40		degree C/W	According to JEDEC JESD51-2, -5, -7 on FR4 2s2p board
	Rth(ch-c)		5		degree C/W	

3.7 Electrical Characteristics

Operation function

Tch=-40 to 150degreeC, Vcc=9 to 16V, 220uF between EXT and OUT, unless otherwise specified

Parameter	Symbol	Min	Typ	Max	Unit	Test Condition	
Operating Voltage	V _{CC}	9		28	V	Von<0.4V, RL=Nomimal load, Refer 3.8.4	
		7.0		9.0	V	Auto flashing operation RL=Nomimal load, Refer 3.8.4	
On-state resistance	Ron		40		mohm	Tch=25°C	
				100		Tch=150°C	RL=Nominal load, Refer 3.8.4
Slew rate on	dV/dton	0.04		1.0	V/μs	VCC=13.5V, RL=Nominal load, Refer 3.8.4, Refer 3.8.5	
Slew rate off	-dV/dtoff	0.04		1.0	V/μs		
Turn on delay time after power supply on 1)	td(on)			100	ms	VCC=13.5V, Tch=-20 to 85°C, RL=Nominal load, , Refer 3.8.4, Refer 3.8.5	
Nominal operation frequency	fnom	1.25	1.4	1.58	Hz	Vcc=13.5V	Tch=25°C, RL=Nominal load, Refer 3.8.4
		0.66				Vcc=7.0 to 9V	Tch=-20 to 85°C, RL=Nominal load, Refer 3.8.4
		1.12	1.4	1.68		Vcc=9 to 16V	
On duty rate	don	35		60	%	Tch=-20 to 85°C, RL=Nominal load, Refer 3.8.4	
Internal clock high level between EXT and OUT	Vexth		6.10		V	VCC=13.5V	
Internal clock low level between EXT and OUT	Vextl		4.95		V	VCC=13.5V	
EXT clamp voltage	Vdd,clamp		7		V	IEXT=2mA, Von=0V	
EXT reverse clamp voltage	Vdd,rev		-0.7		V	IEXT=-2mA, Von=0V	
Supply current via EXT pin	IEXT		708		μA	Von=0V, Vext=5.5V, Tch=25°C	
Double frequency flashing threshold	ldff	0.85	0.96	1.06	A	VCC=9V, Tch=-20 to 85°C	
		1.07	1.20	1.33		VCC=13.5V, Tch=-20 to 85°C	
		1.20	1.34	1.47		VCC=16V, Tch=-20 to 85°C	

1) not subjected production test, guaranteed by design

Protection function

Tch=-40 to 150degreeC, Vcc=9 to 16V, unless other wise specified

Parameter	Symbol	Min	Typ	Max	Unit	Test Condition
Current limitation	IL(LIM)		14		A	VCC=13.5V
Absolute thermal shutdown temperature	aTth	150			degreeC	

3.8 Feature Description

3.8.1 Normal operation

When a nominal load such as defined 3.8.4 is connected to OUT pin, device operate with auto flashing mode by charging EXT capacitor up to the V_{extH} quickly, and then discharging EXT capacitor down to V_{extL} slowly with constant current IEXT.

Auto flashing operation frequency is determined following formula. Duty cycle is approx. 50%.

$$f_{nom} = \frac{I_{EXT}}{2 \times C_{EXT} \times (V_{extH} - V_{extL})}$$

3.8.2 Double flashing operation at low load current condition

If load current is lower than I_{dfl} during on-state, device detects low load condition, and start double flashing operation automatically.

3.8.3 Short circuit protection

The device shuts down automatically when $T_{ch} > aT_{th}$ is detected.

Absolute thermal toggling

Current limitation control with IL(LIM) when auto restart from absolute T_{ch} protection.

3.8.4 Nominal load

Product	Nominal load
RAA290001	8.0ohm

3.8.5 Measurement condition

Switching waveform of OUT terminal

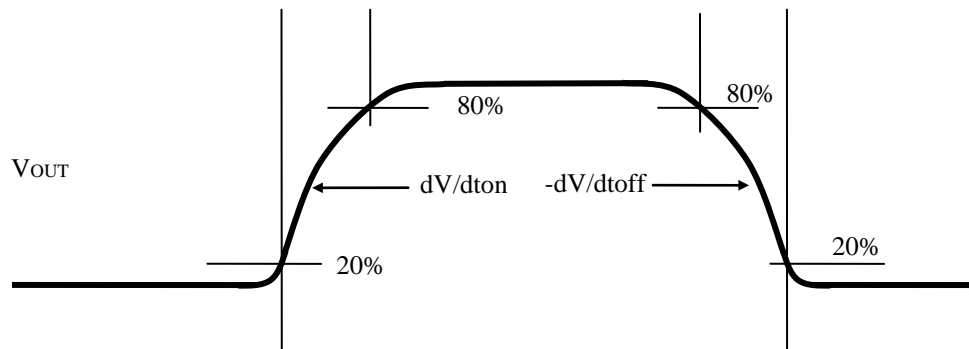

Turn on delay time after Power Supply on

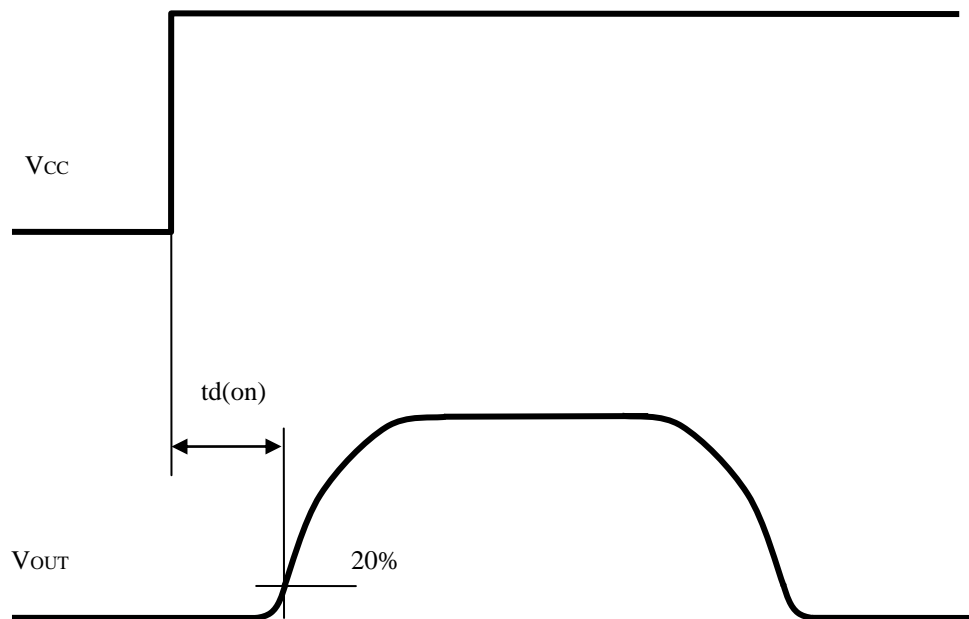

3.8.6 Timing chart

Nominal Operation

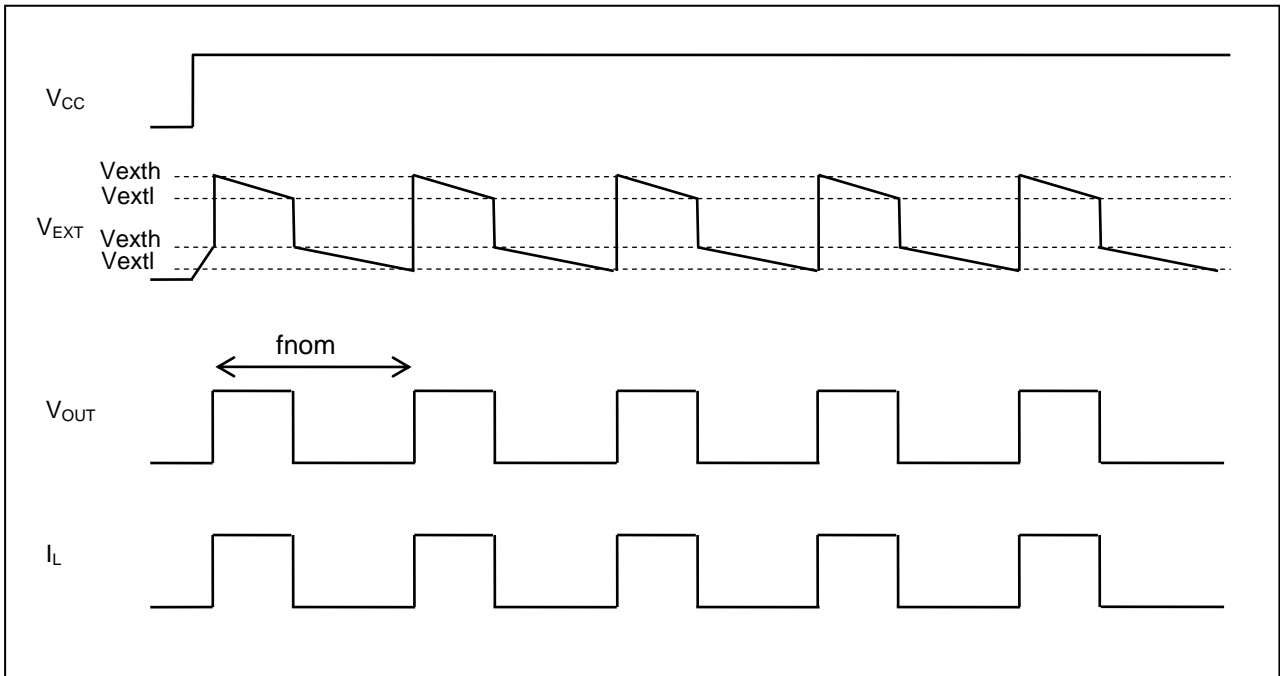

Double flashing operation at low load current condition

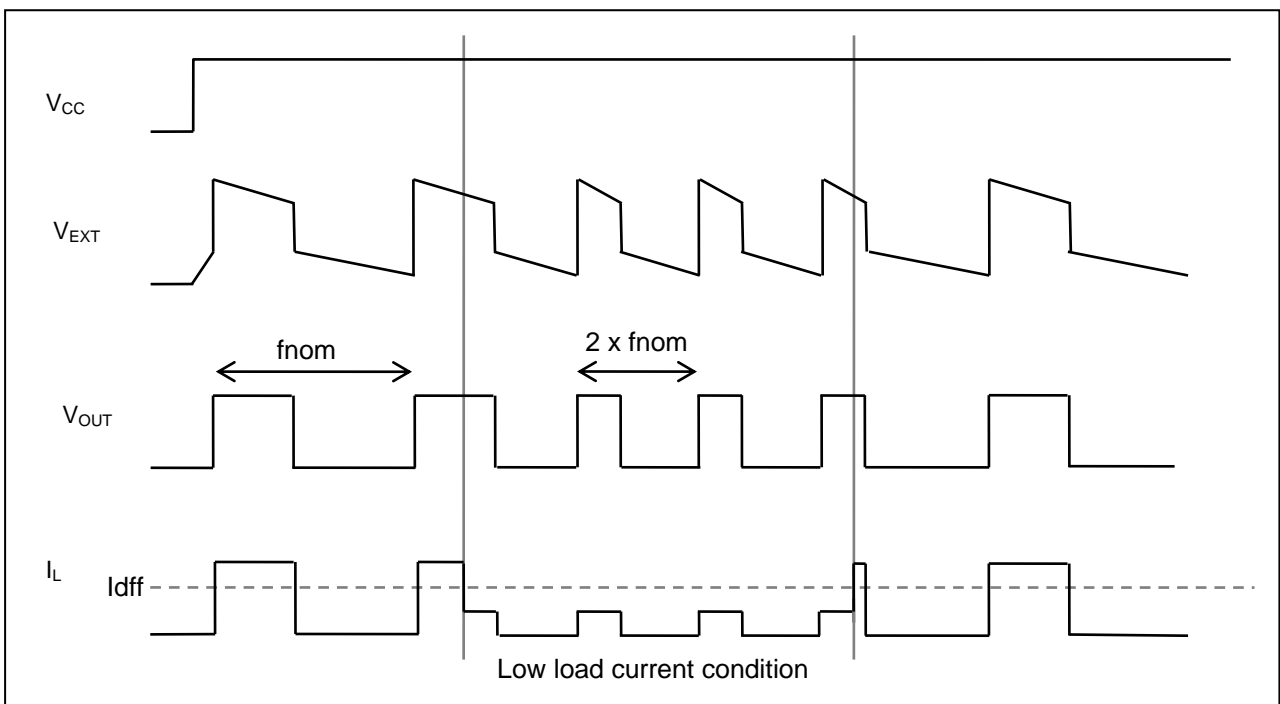

Short circuit protection

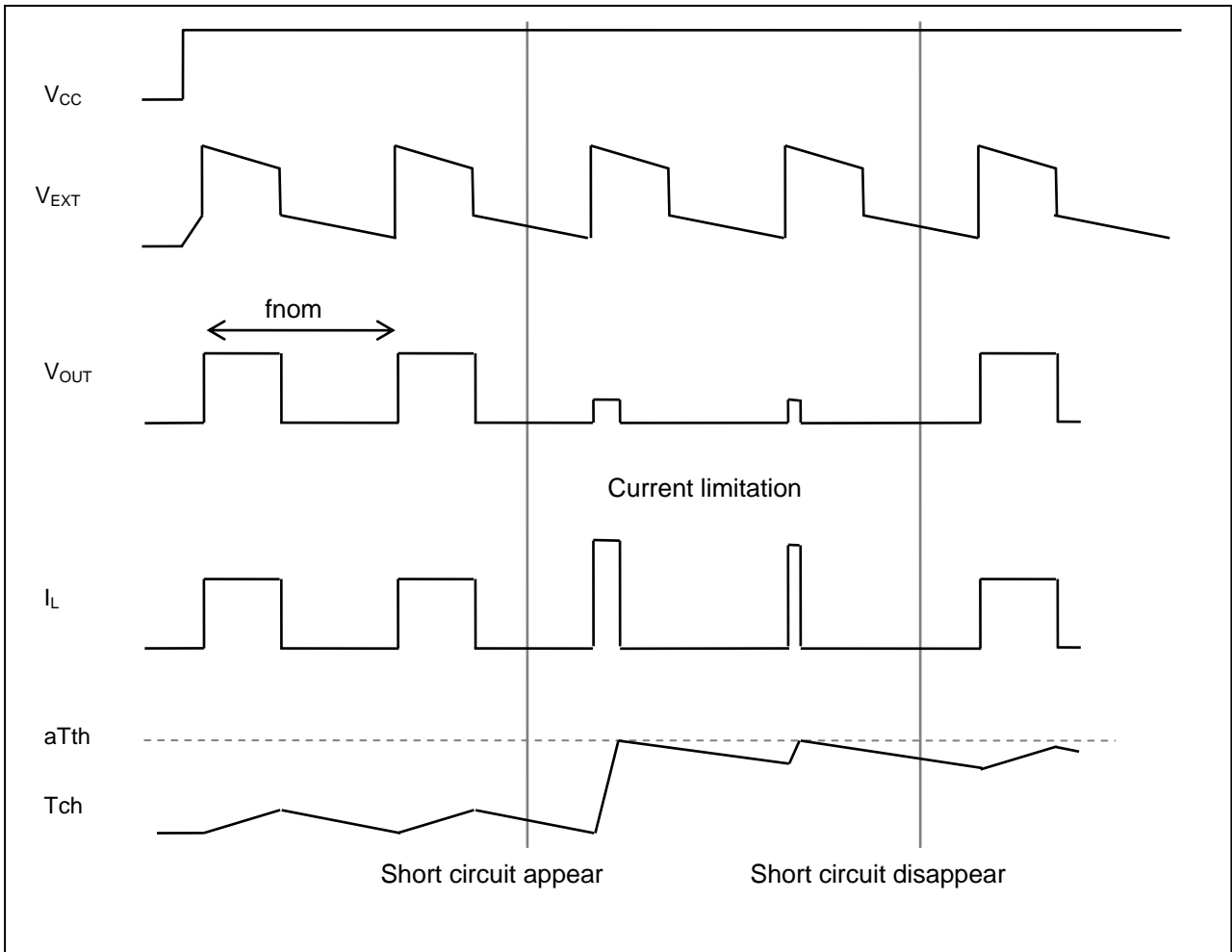

3.9 Package drawing

JEITA Package Code	Renesas Code	Previous Code	Mass(TYP.)[g]
-	PRSS0004ZP-A	P3J5-230-512	0.3

Unit : mm

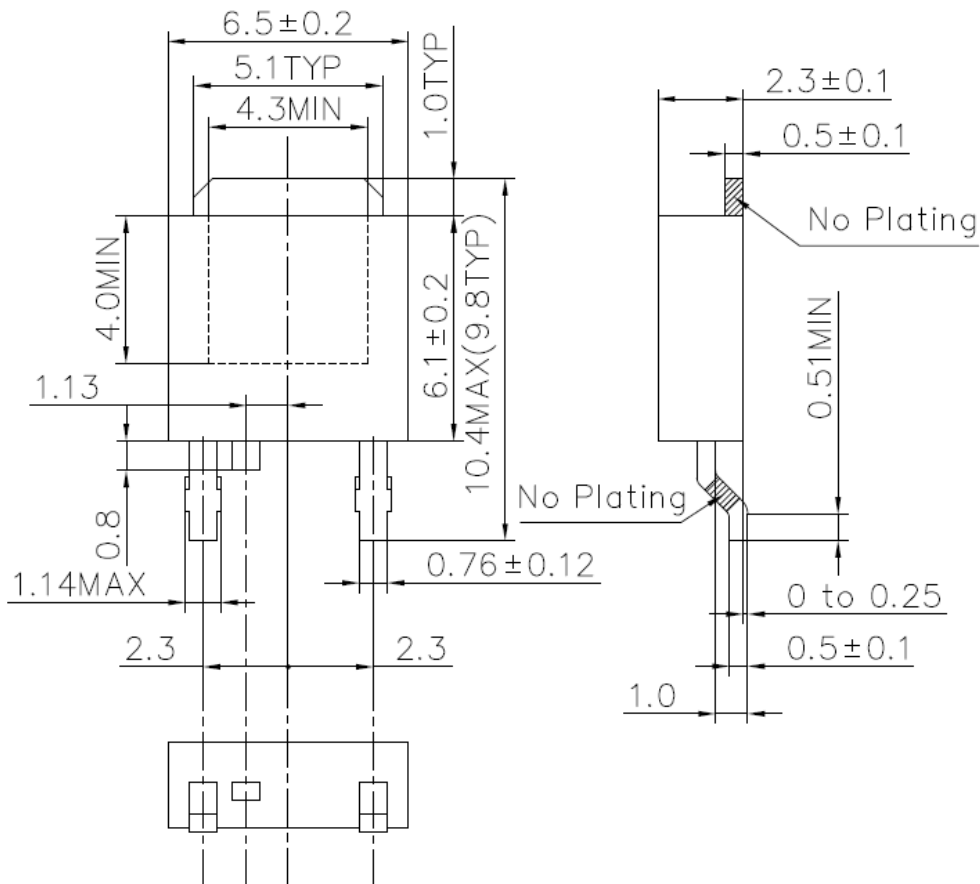

3.10 Taping information

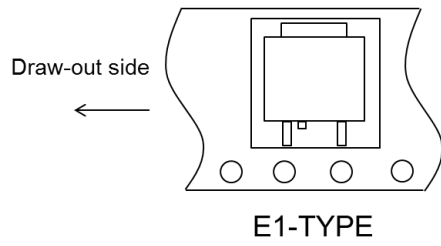

3.11 Marking information

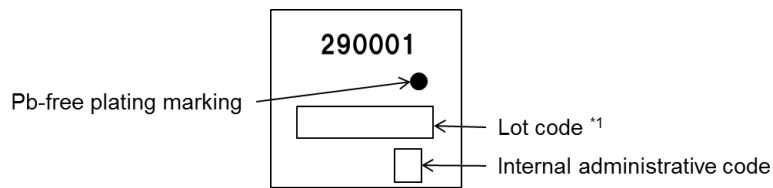

Note: *1. Composition of the lot code

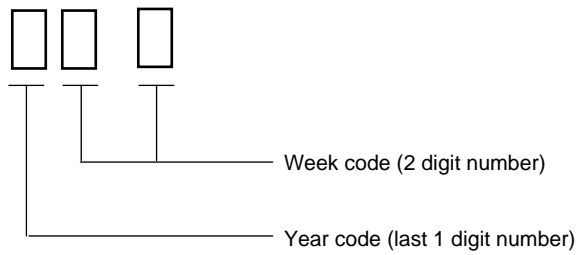

4. Typical characteristics

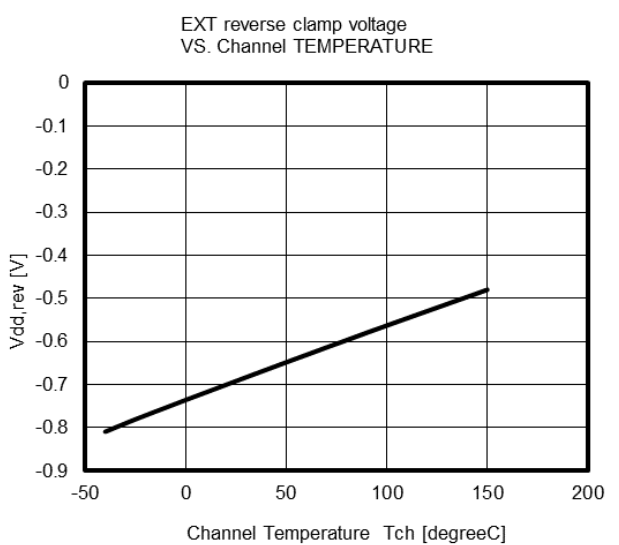
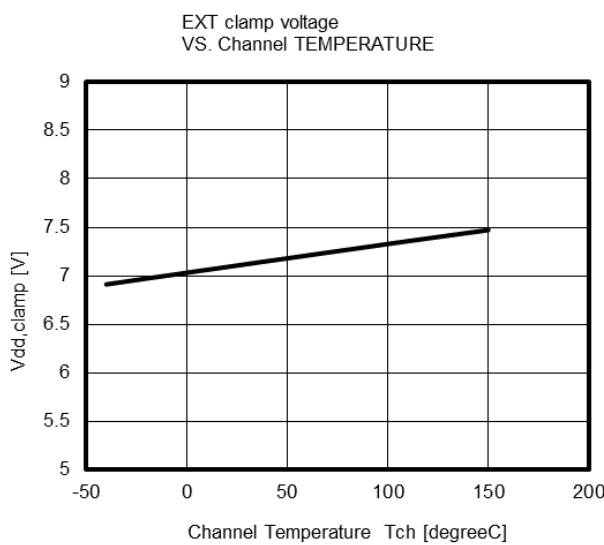
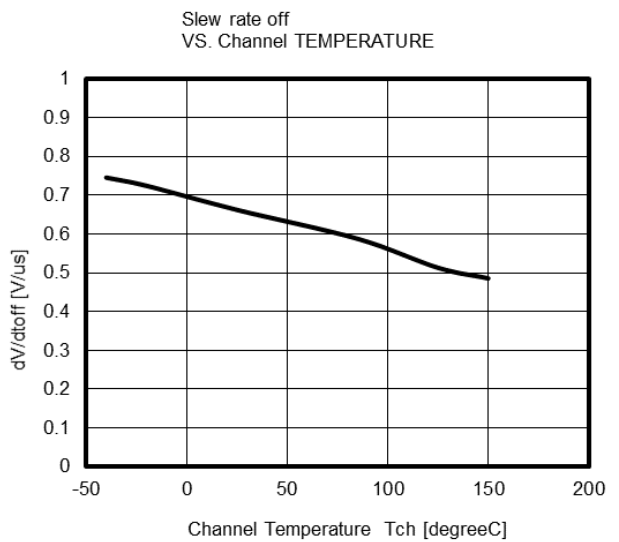
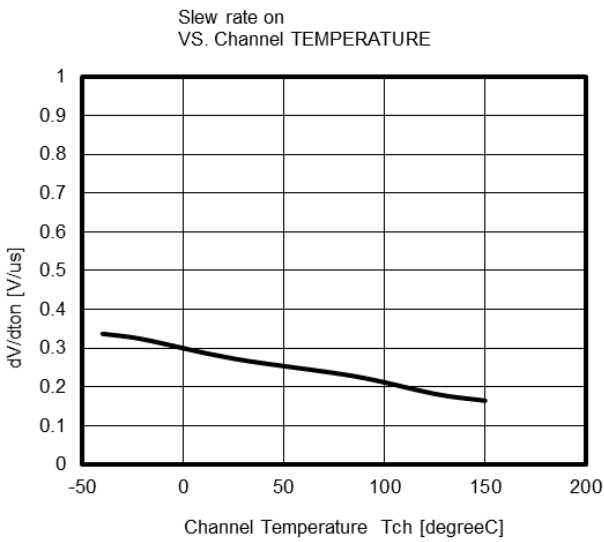
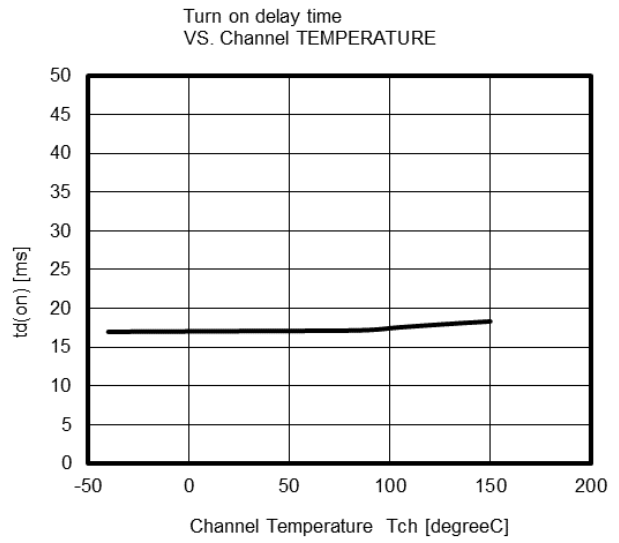
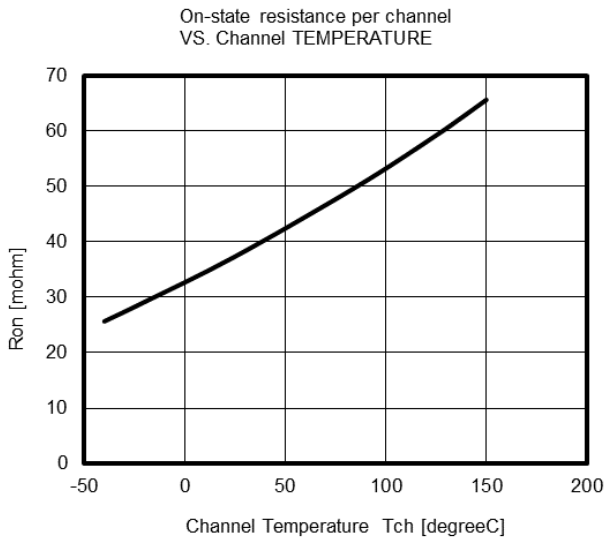

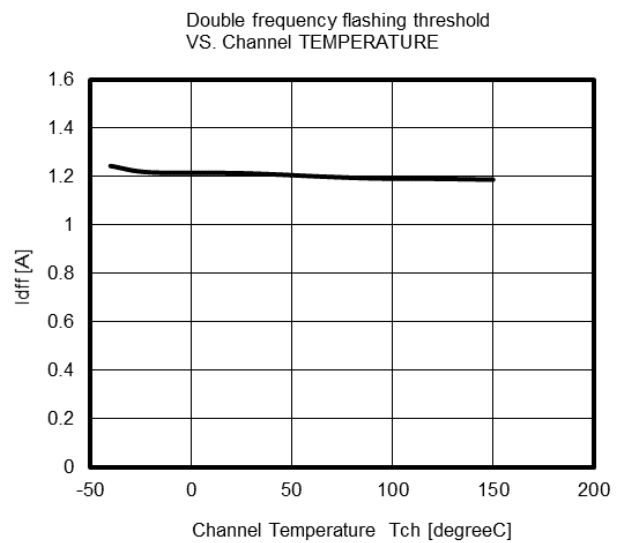
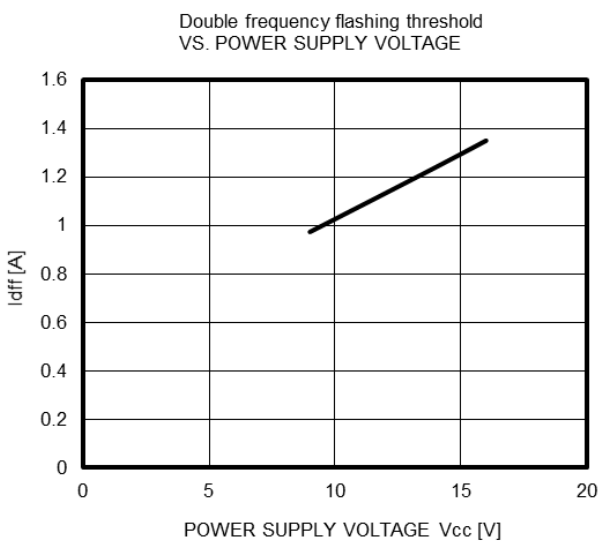
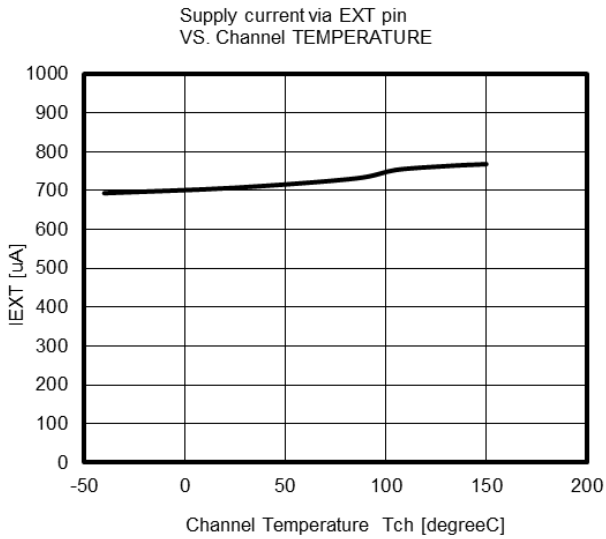
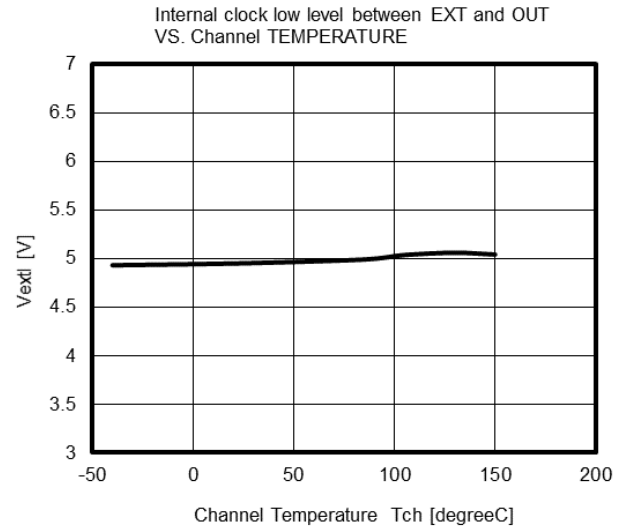
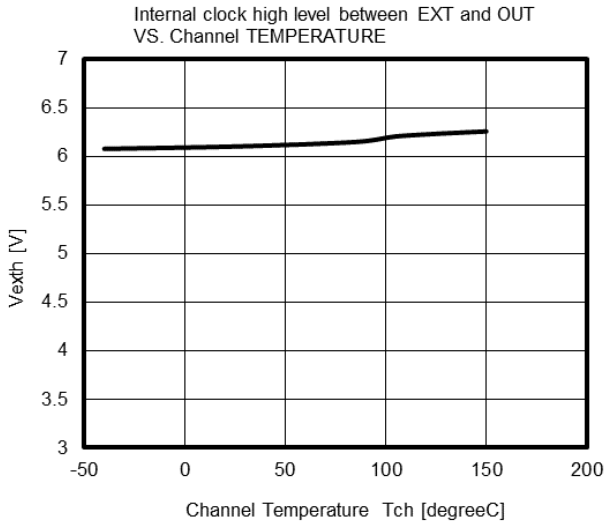

Nominal operation frequency
VS. POWER SUPPLY VOLTAGE

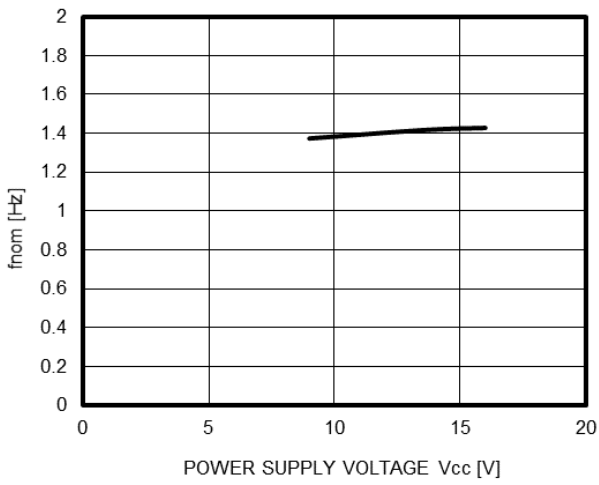

Nominal operation frequency
VS. Channel TEMPERATURE

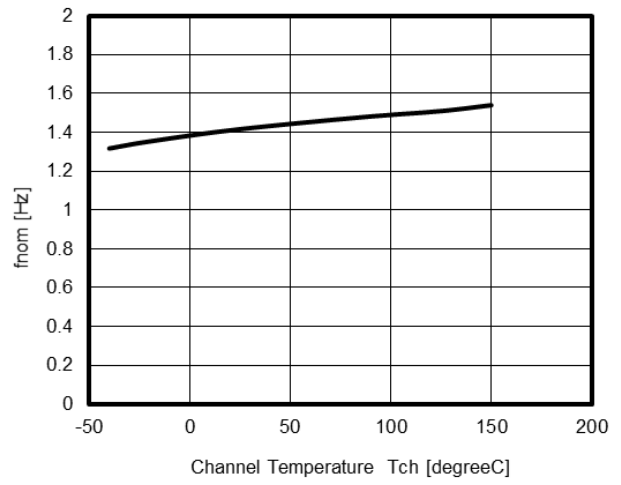

Current limitation
VS. Channel TEMPERATURE

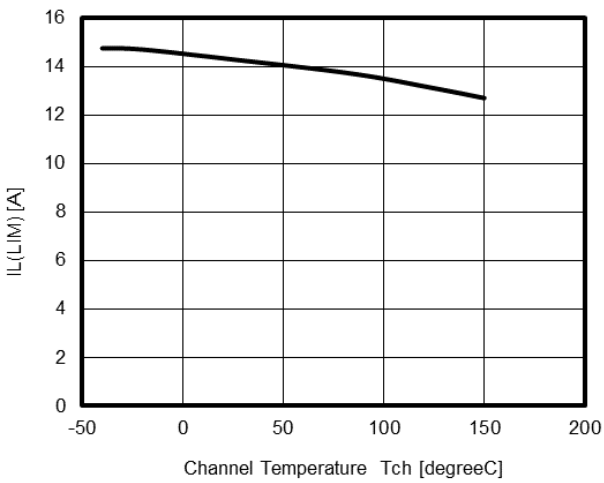

5. Thermal characteristics

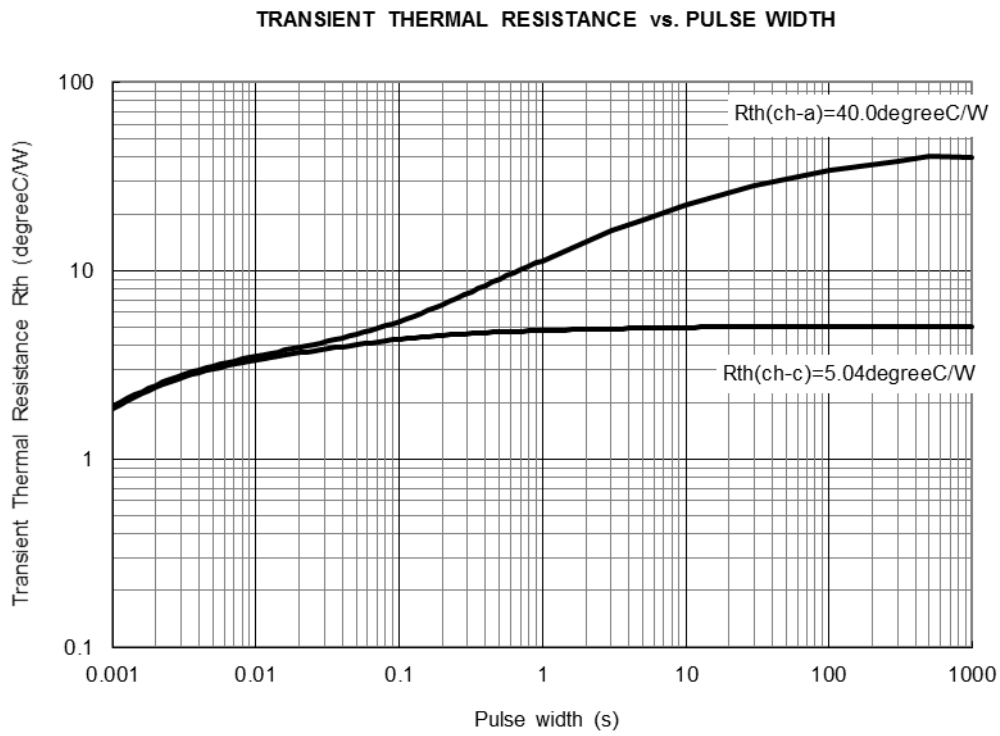

6. Application example in principle

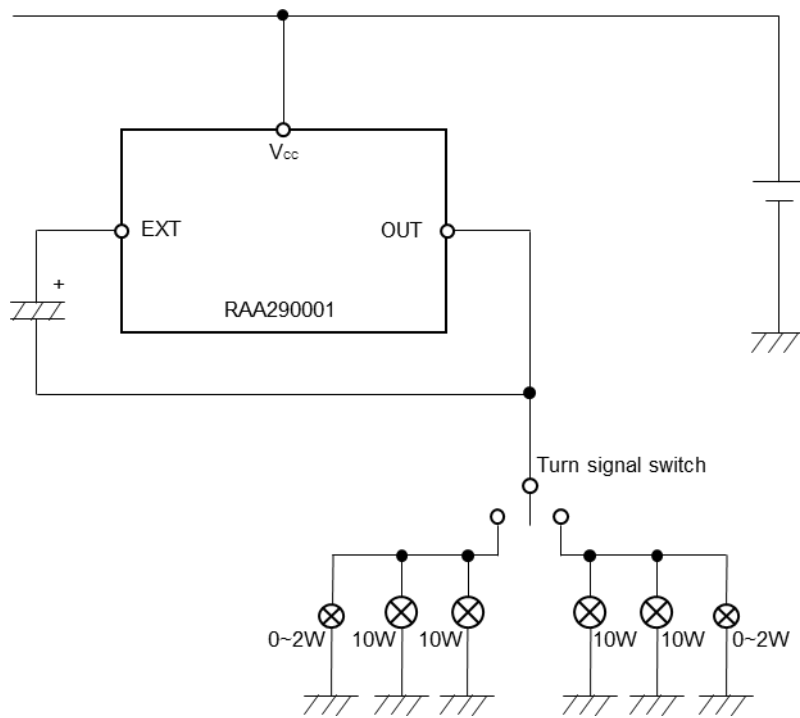

Recommended circuit for dump surge

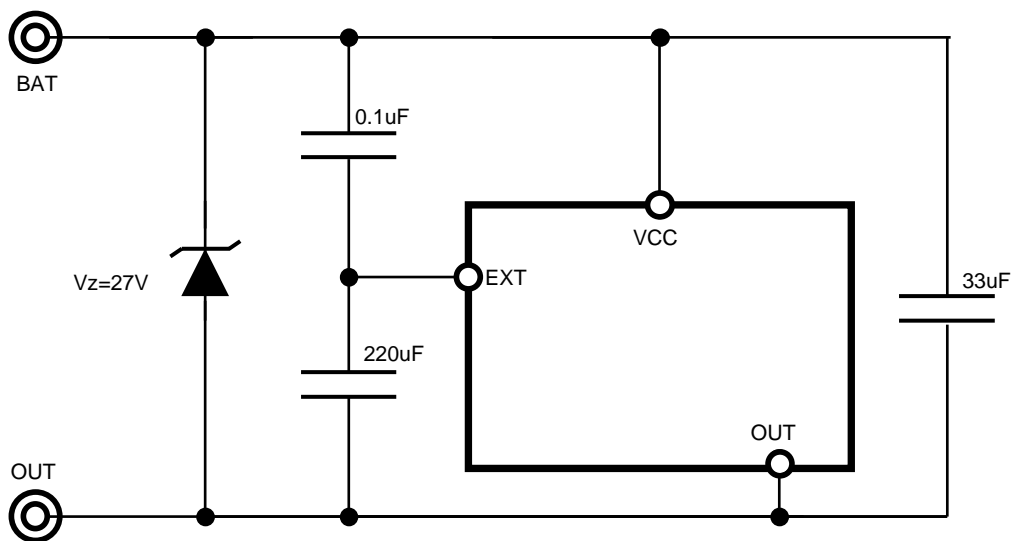

Revision History	RAA290001 Datasheet
-------------------------	----------------------------

Rev.	Date	Description	
		Page	Summary
1.00	Jun 17, 2015	1-17	1st issue

All documents should contain the following section break and paragraph as the last item. The footers of this document refer to the paragraph in order to reference the last page of the document.

All trademarks and registered trademarks are the property of their respective owners.

Notice

1. Descriptions of circuits, software and other related information in this document are provided only to illustrate the operation of semiconductor products and application examples. You are fully responsible for the incorporation of these circuits, software, and information in the design of your equipment. Renesas Electronics assumes no responsibility for any losses incurred by you or third parties arising from the use of these circuits, software, or information.
2. Renesas Electronics has used reasonable care in preparing the information included in this document, but Renesas Electronics does not warrant that such information is error free. Renesas Electronics assumes no liability whatsoever for any damages incurred by you resulting from errors in or omissions from the information included herein.
3. Renesas Electronics does not assume any liability for infringement of patents, copyrights, or other intellectual property rights of third parties by or arising from the use of Renesas Electronics products or technical information described in this document. No license, express, implied or otherwise, is granted hereby under any patents, copyrights or other intellectual property rights of Renesas Electronics or others.
4. You should not alter, modify, copy, or otherwise misappropriate any Renesas Electronics product, whether in whole or in part. Renesas Electronics assumes no responsibility for any losses incurred by you or third parties arising from such alteration, modification, copy or otherwise misappropriation of Renesas Electronics product.
5. Renesas Electronics products are classified according to the following two quality grades: "Standard" and "High Quality". The recommended applications for each Renesas Electronics product depends on the product's quality grade, as indicated below.
Standard: Computers; office equipment; communications equipment; test and measurement equipment; audio and visual equipment; home electronic appliances; machine tools; personal electronic equipment; and industrial robots etc.
High Quality: Transportation equipment (automobiles, trains, ships, etc.); traffic control systems; anti-disaster systems; anti-crime systems; and safety equipment etc.
Renesas Electronics products are neither intended nor authorized for use in products or systems that may pose a direct threat to human life or bodily injury (artificial life support devices or systems, surgical implantations etc.), or may cause serious property damages (nuclear reactor control systems, military equipment etc.). You must check the quality grade of each Renesas Electronics product before using it in a particular application. You may not use any Renesas Electronics product for any application for which it is not intended. Renesas Electronics shall not be in any way liable for any damages or losses incurred by you or third parties arising from the use of any Renesas Electronics product for which the product is not intended by Renesas Electronics.
6. You should use the Renesas Electronics products described in this document within the range specified by Renesas Electronics, especially with respect to the maximum rating, operating supply voltage range, movement power voltage range, heat radiation characteristics, installation and other product characteristics. Renesas Electronics shall have no liability for malfunctions or damages arising out of the use of Renesas Electronics products beyond such specified ranges.
7. Although Renesas Electronics endeavors to improve the quality and reliability of its products, semiconductor products have specific characteristics such as the occurrence of failure at a certain rate and malfunctions under certain use conditions. Further, Renesas Electronics products are not subject to radiation resistance design. Please be sure to implement safety measures to guard them against the possibility of physical injury, and injury or damage caused by fire in the event of the failure of a Renesas Electronics product, such as safety design for hardware and software including but not limited to redundancy, fire control and malfunction prevention, appropriate treatment for aging degradation or any other appropriate measures. Because the evaluation of microcomputer software alone is very difficult, please evaluate the safety of the final products or systems manufactured by you.
8. Please contact a Renesas Electronics sales office for details as to environmental matters such as the environmental compatibility of each Renesas Electronics product. Please use Renesas Electronics products in compliance with all applicable laws and regulations that regulate the inclusion or use of controlled substances, including without limitation, the EU RoHS Directive. Renesas Electronics assumes no liability for damages or losses occurring as a result of your noncompliance with applicable laws and regulations.
9. Renesas Electronics products and technology may not be used for or incorporated into any products or systems whose manufacture, use, or sale is prohibited under any applicable domestic or foreign laws or regulations. You should not use Renesas Electronics products or technology described in this document for any purpose relating to military applications or use by the military, including but not limited to the development of weapons of mass destruction. When exporting the Renesas Electronics products or technology described in this document, you should comply with the applicable export control laws and regulations and follow the procedures required by such laws and regulations.
10. It is the responsibility of the buyer or distributor of Renesas Electronics products, who distributes, disposes of, or otherwise places the product with a third party, to notify such third party in advance of the contents and conditions set forth in this document, Renesas Electronics assumes no responsibility for any losses incurred by you or third parties as a result of unauthorized use of Renesas Electronics products.
11. This document may not be reproduced or duplicated in any form, in whole or in part, without prior written consent of Renesas Electronics.
12. Please contact a Renesas Electronics sales office if you have any questions regarding the information contained in this document or Renesas Electronics products, or if you have any other inquiries.

(Note 1) "Renesas Electronics" as used in this document means Renesas Electronics Corporation and also includes its majority-owned subsidiaries.

(Note 2) "Renesas Electronics product(s)" means any product developed or manufactured by or for Renesas Electronics.



SALES OFFICES

Renesas Electronics Corporation

<http://www.renesas.com>

Refer to "<http://www.renesas.com/>" for the latest and detailed information.

Renesas Electronics America Inc.
2801 Scott Boulevard Santa Clara, CA 95050-2549, U.S.A.
Tel: +1-408-588-6000, Fax: +1-408-588-6130

Renesas Electronics Canada Limited
9251 Yonge Street, Suite 8309 Richmond Hill, Ontario Canada L4C 9T3
Tel: +1-905-237-2004

Renesas Electronics Europe Limited
Dukes Meadow, Millboard Road, Bourne End, Buckinghamshire, SL8 5FH, U.K
Tel: +44-1628-585-100, Fax: +44-1628-585-900

Renesas Electronics Europe GmbH
Arcadiastrasse 10, 40472 Düsseldorf, Germany
Tel: +49-211-6503-0, Fax: +49-211-6503-1327

Renesas Electronics (China) Co., Ltd.
Room 1709, Quantum Plaza, No.27 ZhichunLu Haidian District, Beijing 100191, P.R.China
Tel: +86-10-8235-1155, Fax: +86-10-8235-7679

Renesas Electronics (Shanghai) Co., Ltd.
Unit 301, Tower A, Central Towers, 555 Langao Road, Putuo District, Shanghai, P. R. China 200333
Tel: +86-21-2226-0888, Fax: +86-21-2226-0899

Renesas Electronics Hong Kong Limited
Unit 1601-1611, 16/F., Tower 2, Grand Century Place, 193 Prince Edward Road West, Mongkok, Kowloon, Hong Kong
Tel: +852-2265-6688, Fax: +852-2886-9022

Renesas Electronics Taiwan Co., Ltd.
13F, No. 363, Fu Shing North Road, Taipei 10543, Taiwan
Tel: +886-2-8175-9600, Fax: +886-2-8175-9670

Renesas Electronics Singapore Pte. Ltd.
80 Bendemeer Road, Unit #06-02 Hyflux Innovation Centre, Singapore 339949
Tel: +65-6213-0200, Fax: +65-6213-0300

Renesas Electronics Malaysia Sdn.Bhd.
Unit 1207, Block B, Menara Amcorp, Amcorp Trade Centre, No. 18, Jln Persiaran Barat, 46050 Petaling Jaya, Selangor Darul Ehsan, Malaysia
Tel: +60-3-7955-9390, Fax: +60-3-7955-9510

Renesas Electronics India Pvt. Ltd.
No.777C, 100 Feet Road, HAL - Stage, Indiranagar, Bangalore, India
Tel: +91-80-67208700, Fax: +91-80-67208777

Renesas Electronics Korea Co., Ltd.
12F., 234 Teheran-ro, Gangnam-Gu, Seoul, 135-080, Korea
Tel: +82-2-558-3737, Fax: +82-2-558-5141