

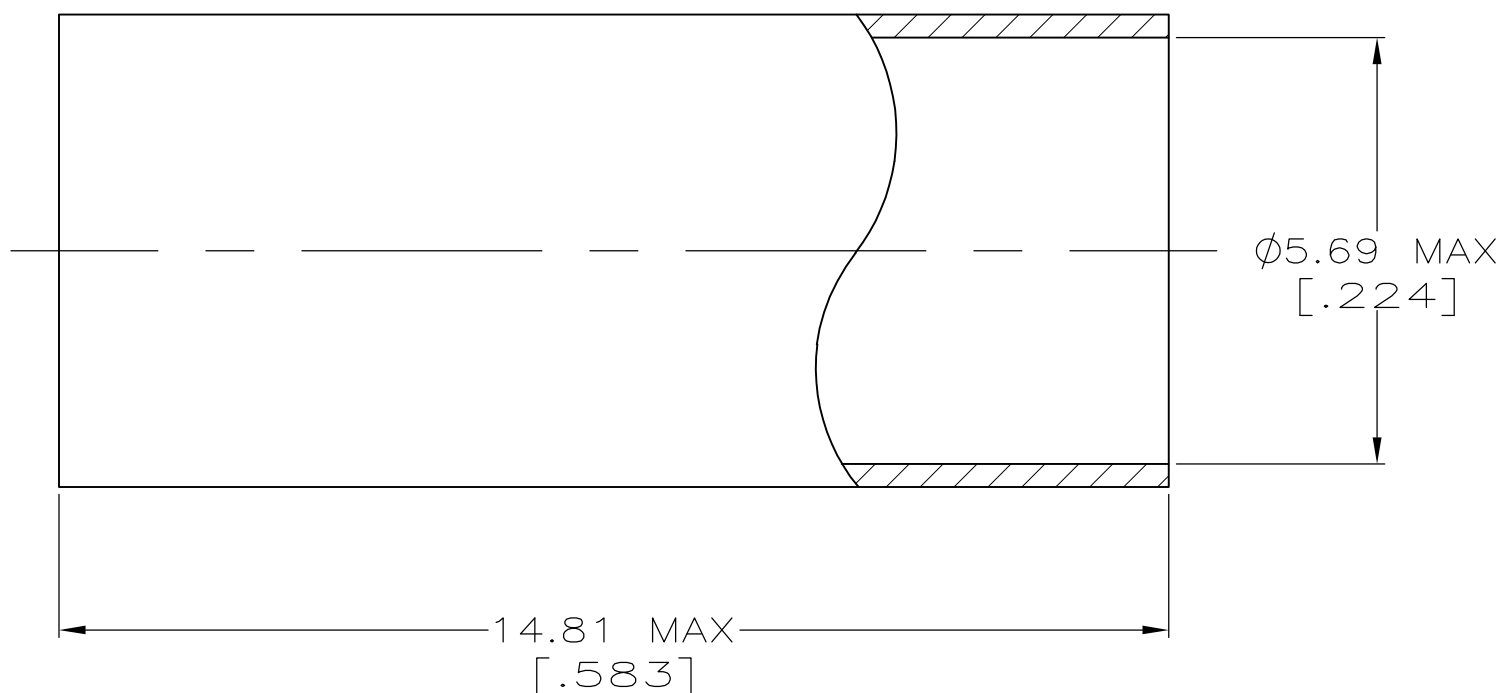

THIS DRAWING IS UNPUBLISHED. RELEASED FOR PUBLICATION  
 © COPYRIGHT - By - ALL RIGHTS RESERVED.

LOC	DIST	REVISIONS			
P	LTR	DESCRIPTION	DATE	DWN	APVD
	V	ECO-14-003590	21FEB14	AM	MY



- 1. COPPER ALLOY
- 2. SILVER PLATE PER QQ-S-365, 5.08 $\mu$ m (.000200) MIN THICKNESS (NON-ROHS).
- 3. TIN-LEAD PLATE PER ASTM-B-545, 2.54 $\mu$ m (.000100) MIN THICKNESS, WITH SUPPLEMENTAL ANTI FRETTING LUBRICANT.
- 4. GOLD PLATE PER MIL-G-45204, 0.76 $\mu$ m (.000030) MIN THICKNESS.
- 5. MATTE TIN PLATE PER MIL-T-10727, 2.54 $\mu$ m (.000100) MIN THICKNESS, WITH SUPPLEMENTAL ANTI FRETTING LUBRICANT.
- 6. SILVER PLATE 5.08 $\mu$ m (.000200) MIN THICKNESS, (ROHS).

6	9-225382-1
5	9-225382-0
4	225382-5
3	225382-3
2	225382-2
FINISH	PART NUMBER

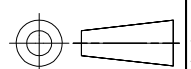
THIS DRAWING IS A CONTROLLED DOCUMENT.		DWN MICHAEL E. COWHER 14NOV95	 TE Connectivity			
DIMENSIONS: mm [INCHES]		CHK FRANK MORANA 14NOV95				
TOLERANCES UNLESS OTHERWISE SPECIFIED:		APVD FRANK MORANA 14NOV95	NAME FERRULE			
 0 PLC ± - 1 PLC ± - 2 PLC ± - 3 PLC ± - 4 PLC ± - ANGLES ± -		PRODUCT SPEC -	RESTRICTED TO -			
MATERIAL SEE NOTES		FINISH SEE NOTES	APPLICATION SPEC -	SIZE A3	CAGE CODE 00779	DRAWING NO C-225382
CUSTOMER DRAWING			WEIGHT -	SCALE 10:1	SHEET 1 OF 1	REV V