

Getting started with the STEVAL-SPIN3202 evaluation board, advanced BLDC controller with embedded STM32 MCU

Introduction

The STEVAL-SPIN3202 three-phase brushless DC motor driver board is based on the STSPIN32F0A 3-phase controller with integrated STM32 MCU and STD140N6F7 MOSFETs.

It implements a single shunt resistor current reading topology and provides an easy-to-use solution for the implementation of home appliances, fans, drones, power tools, and low voltage motor driving applications.

The board is designed for sensored or sensorless vector control FOC and six-step algorithms with single shunt sensing.

Figure 1. STEVAL-SPIN3202 evaluation board

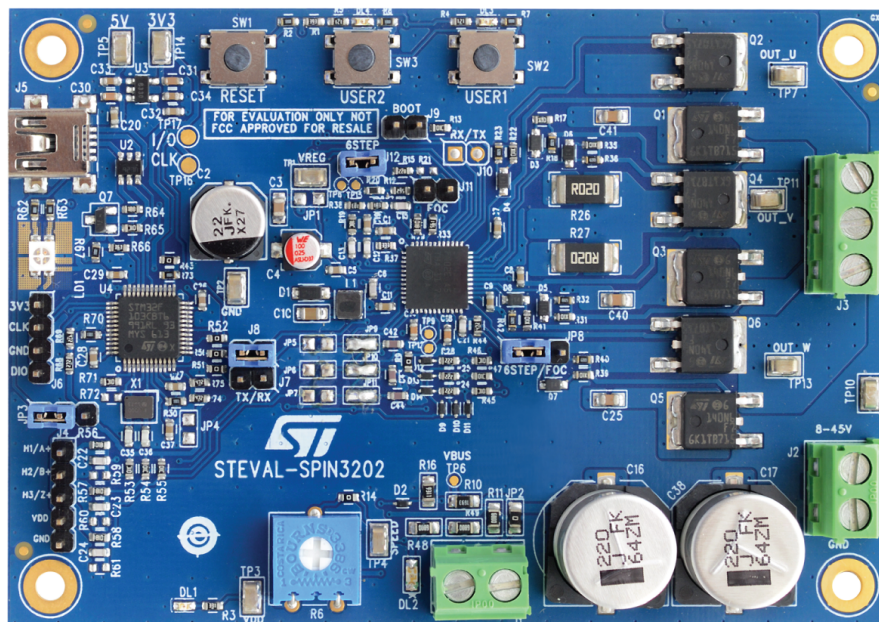

1 Hardware and software requirements

Using the [STEVAL-SPIN3202](#) evaluation board requires the following software and hardware:

- a Windows[®] PC (XP, Vista 7, Windows 8, Windows 10) to install the software package;
- a mini-B USB cable to connect the [STEVAL-SPIN3202](#) evaluation board to the PC;
- a firmware package based on the STM32 Motor Control SDK ([X-CUBE-MCSDK-Y](#));
- a 3-phase brushless DC motor with compatible voltage and current ratings;
- an external DC power supply.

2 Getting started

To use the board:

1. Check the jumper position according to the target configuration (see [Section 2.2.1 Six-step/FOC selection](#))
2. Connect the motor to J3 connector taking care of the motor phases sequence
3. Supply the board via J2 connector input 1 and 2; the DL1 (red) LED turns on
4. Connect the board to the PC through the USB cable
5. Develop your application using the STM32 Motor Control SDK X-CUBE-MCSDK-Y.

Note:

The board maximum ratings are:

- power stage supply voltage (VS) from 6.7 V to 45 V;
- motor phase current up to 15 A_{rms}.

2.1 Hardware description and configuration

Figure 2. STEVAL-SPIN3202 evaluation board: jumper and connector positions

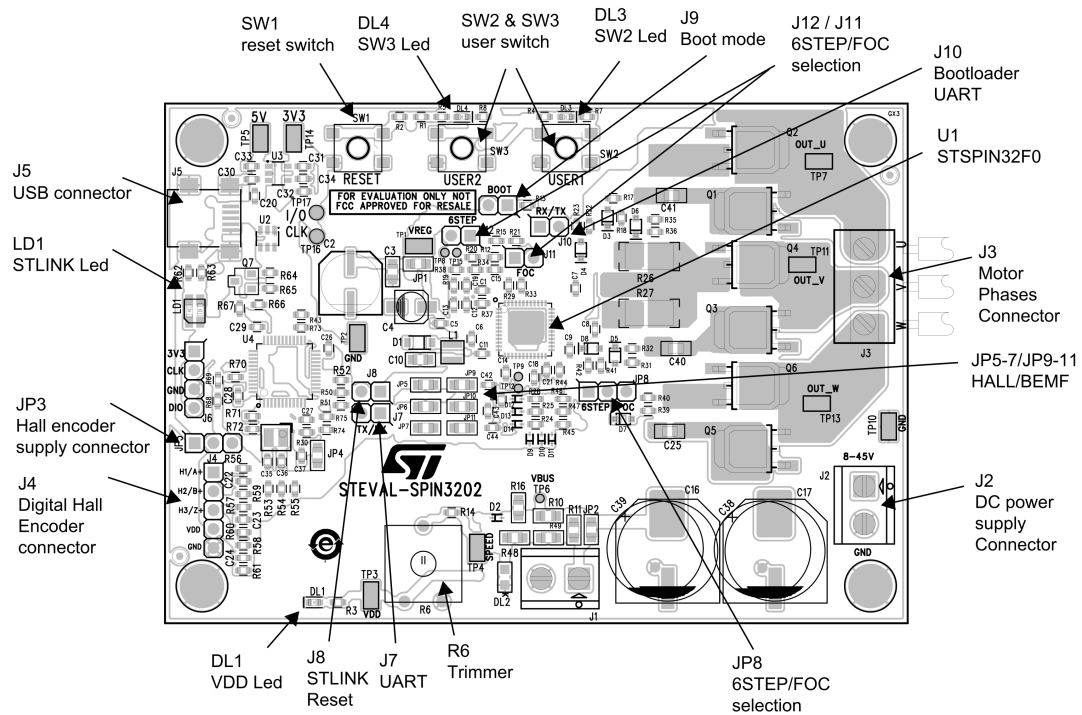

Table 1. Hardware setting jumpers

Jumper	Permitted configurations	Default condition
JP1	Selection of VREG connected to V motor	OPEN
JP2	Selection motor power supply connected to DC power supply	CLOSED
JP3	Selection Hall encoder supply to USB (1)/VDD (3) power supply	1-2 CLOSED
JP4	Selection reset of ST-LINK (U4)	OPEN
JP5	Selection PA0 connected to Hall 1	OPEN
JP6	Selection PA1 connected to Hall 2	OPEN
JP7	Selection PA2 connected to Hall 3	OPEN

Jumper	Permitted configurations	Default condition
JP8	Selection mode 6STEP/FOC	1-2 CLOSED
J11	Selection mode FOC	CLOSED
J12	Selection mode 6STEP	OPEN
JP9	Selection PA0 connected to OUT U	CLOSED
JP10	Selection PA1 connected to OUT V	CLOSED
JP11	Selection PA2 connected to OUT W	CLOSED

Table 2. Connectors, jumpers and test points

Name	Pin	Label	Description
J1	1-2	J1	Motor power supply
J2	1-2	J2	Device main power supply (VM)
J3	1-2-3	U, V, W	3-phase BLDC motor phase connection
J4	1-2-3	J4	Hall sensors/encoder connector
	4-5	J4	Hall sensors/encoder supply
J5	-	J5	USB input ST-LINK
J7	1-2	J7	UART (ST-LINK Virtual COM)
J8	1-2	J8	ST-LINK reset
J9	1-2	BOOT	Boot mode
J10	1-2	RX/TX	Bootloader UART connector
TP1	-	VREG	12 V voltage regulator output
TP2	-	GND	GND
TP3	-	VDD	VDD
TP4	-	SPEED	Speed potentiometer output
TP5	-	5V	USB supply voltage
TP6	-	VBUS	Bus voltage feedback
TP7	-	OUT_U	Output U
TP8	-	TP8	Output op amp sense 2
TP9	-	TP9	PA5 GPIO
TP10	-	GND	GND
TP11	-	OUT_V	Output V
TP12	-	TP12	GPIO BEMF
TP13	-	OUT_W	Output W
TP14	-	3V3	3V3 ST-LINK
TP15	-	TP15	Output op amp sense 3
TP16	-	CLK	SWD_CLK
TP17	-	I/O	SWD_IO

2.2 Circuit description

The STEVAL-SPIN3202 evaluation board provides a complete single-shunt six-step solution consisting of an STSPIN32F0A advanced BLDC controller with an embedded STM32 MCU and a triple half-bridge power stage with the STD140N6F7 NMOS.

The STSPIN32F0A autonomously generates all the required supply voltages starting from the motor supply: the internal DC/DC buck converter provides 3.3 V and the internal linear regulator provides 12 V for the gate drivers.

The current feedback signal conditioning is performed through the operational amplifiers embedded in the device and an internal comparator performs overcurrent protection via the shunt resistor.

Two user buttons, two LEDs and a trimmer are available to implement simple user interfaces (e.g., starting/stopping the motor and set target speed).

The STEVAL-SPIN3202 evaluation board supports the quadrature encoder and digital Hall sensors for motor position feedback. It also provides the circuitry to sense the motor BEMF (sensorless operation).

The board includes an ST-LINK/V2 which allows the user to debug and download firmware without additional hardware.

The board also supports sensed or sensorless field oriented control algorithm with single-shunt sensing.

2.2.1 Six-step/FOC selection

The user can select between six-step and field oriented control modes by selecting different jumpers on the STEVAL-SPIN3202 evaluation board.

The FOC mode is selected as per the following configuration:

- jumper connected on J12 open and jumper J11 closed;
- jumper connected on JP8 between pin 2 and 3 (FOC position).

The six-step mode is selected as follows:

- jumper connected on J12 closed and remove jumper from J11;
- jumper connected on JP8 between pin 1 and 2 (six-step position).

2.2.2 Hall/encoder motor speed sensor

The STEVAL-SPIN3202 evaluation board supports the digital Hall and quadrature encoder sensors as motor position feedback.

The sensors can be connected to the STSPIN32F0A by closing jumpers JP5, JP6 and JP7 (open by default).

Note: When JP5, JP6 and JP7 are closed (Hall/encoder mode), JP9, JP10 and JP11 should be respectively open (BEMF sensing mode).

The Hall sensor/encoder should be connected to J4 as per the following table.

Table 3. Hall/encoder connector (J4)

Name	Pin	Description
Hall1/A+	1	Hall sensor 1/encoder out A+
Hall2/B+	2	Hall sensor 2/encoder out B+
Hall3/Z+	3	Hall sensor 3/encoder zero feedback
V _{DD} sensor	4	Sensor supply voltage
GND	5	Ground

A protection resistor of 1 kΩ is mounted in series with the sensor outputs.

For sensors requiring an external pull-up, three 10 kΩ resistors are already mounted on the output lines and connected to the VDD voltage. On the same lines, a footprint for pull-down resistors is also available.

JP3 jumper selects the power supply for the sensor supply voltage:

- jumper between pin 1 and pin 2: Hall sensors powered by V_{USB} (5 V)
- jumper between pin 1 and pin 2: Hall sensors powered by V_{DD} (3.3 V)

2.2.3 Overcurrent detection and current sensing measurement

The [STEVAL-SPIN3202](#) evaluation board implements overcurrent protection based on the [STSPIN32F0A](#) integrated OC comparator.

The shunt resistor measures the load current. R26 and R27 resistors bring the voltage signal to the OC_COMP pin. When the peak current flowing through the shunt exceeds the selected threshold, the integrated comparator is triggered and all the high side power switches are disabled.

The current threshold of the [STEVAL-SPIN3202](#) varies according to the [STSPIN32F0A](#) OC threshold as listed in the following table.

Table 4. Overcurrent thresholds

PF6	PF7	Internal comp. threshold	OC threshold
0	1	100 mV	20 A
1	0	250 mV	65 A
1	1	500 mV	140 A

2.2.4 Bus voltage sensing circuit

The [STEVAL-SPIN3202](#) evaluation board provides the bus voltage sensing. This signal is set through a voltage divider by the motor supply voltage (V_{BUS} , R10 and R16) and sent to the PB1 GPIO (the ADC channel 9) of the embedded MCU. The signal is also available on TP6.

2.2.5 Hardware user interface

The board provides the following hardware user interface:

- potentiometer (R6 setting, for example, the target speed)
- switch SW1 (to reset [STSPIN32F0A](#) MCU and [ST-LINK/V2](#))
- switch SW2 (user button 1)
- Switch SW3 (user button 2)
- LED DL3 (user LED 1, turned on when the user 1 button is pressed too)
- LED DL4 (user LED 2, turned on when the user 2 button is pressed too)

2.2.6 Debug

The [STEVAL-SPIN3202](#) evaluation board embeds an [ST-LINK/V2](#) debugger/programmer.

The [ST-LINK/V2](#) features:

- USB software re-enumeration
- virtual com port interface on USB connected to the [STSPIN32F0A](#) (UART1) PB6/PB7 pins
- mass storage interface on USB

The [ST-LINK/V2](#) is supplied by the host PC through the USB cable connected to the board.

LD1 LED signals [ST-LINK/V2](#) communication status:

- Red LED flashing slowly: at power-on before USB initialization
- Red LED flashing quickly: following the first successful communication between the PC and [ST-LINK/V2](#) (enumeration)
- Red LED ON: the initialization between the PC and [ST-LINK/V2](#) is complete
- Green LED ON: successful target communication initialization
- Red/green LED flashing: during communication with target
- Green ON: communication successfully completed

The reset function is activated by removing J8 jumper.

3 Schematic diagrams

Figure 3. STEVAL-SPIN3202 schematic (1 of 4)

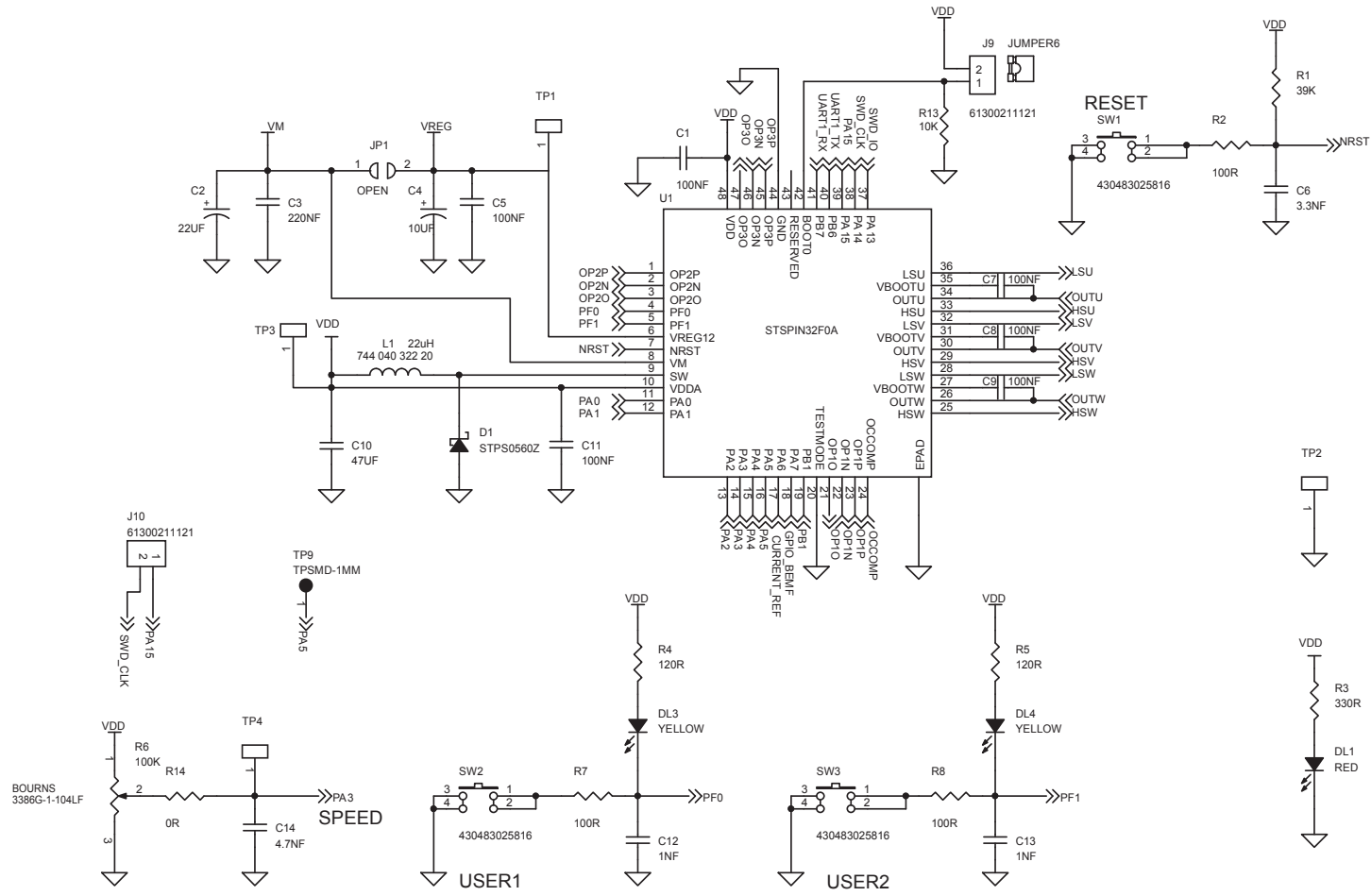

Figure 4. STEVAL-SPIN3202 schematic (2 of 4)

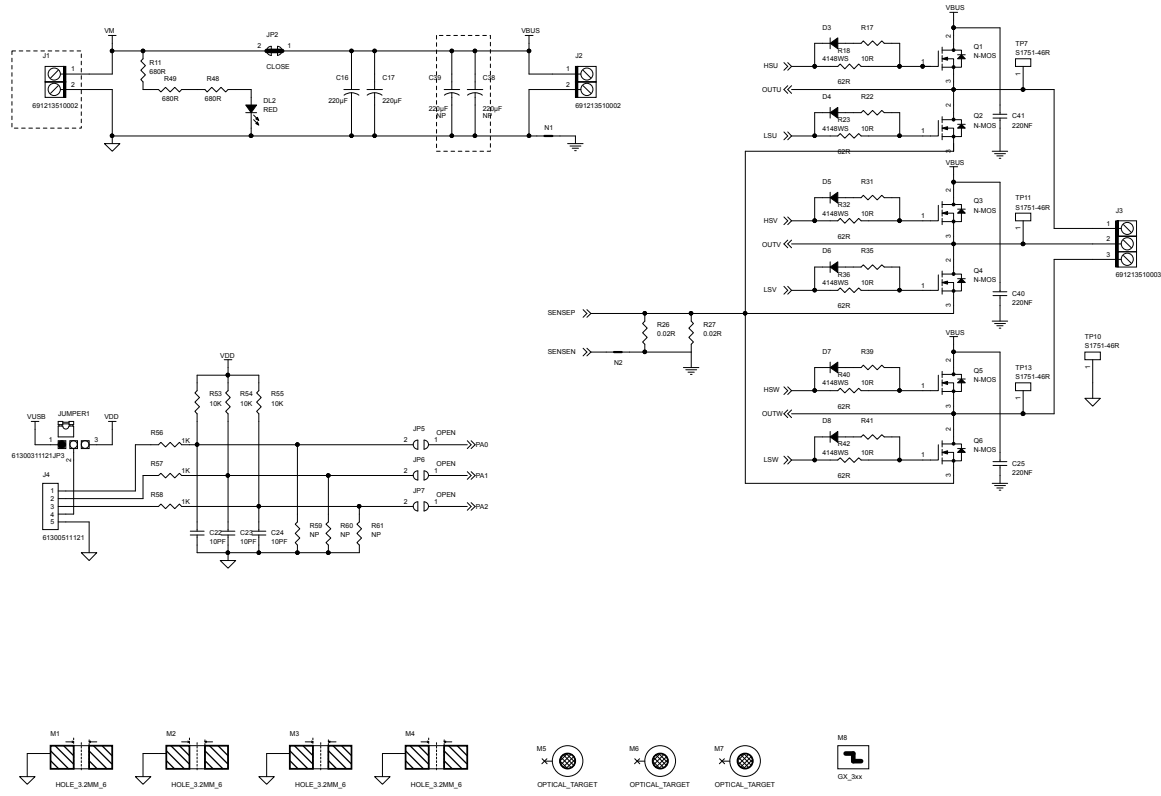
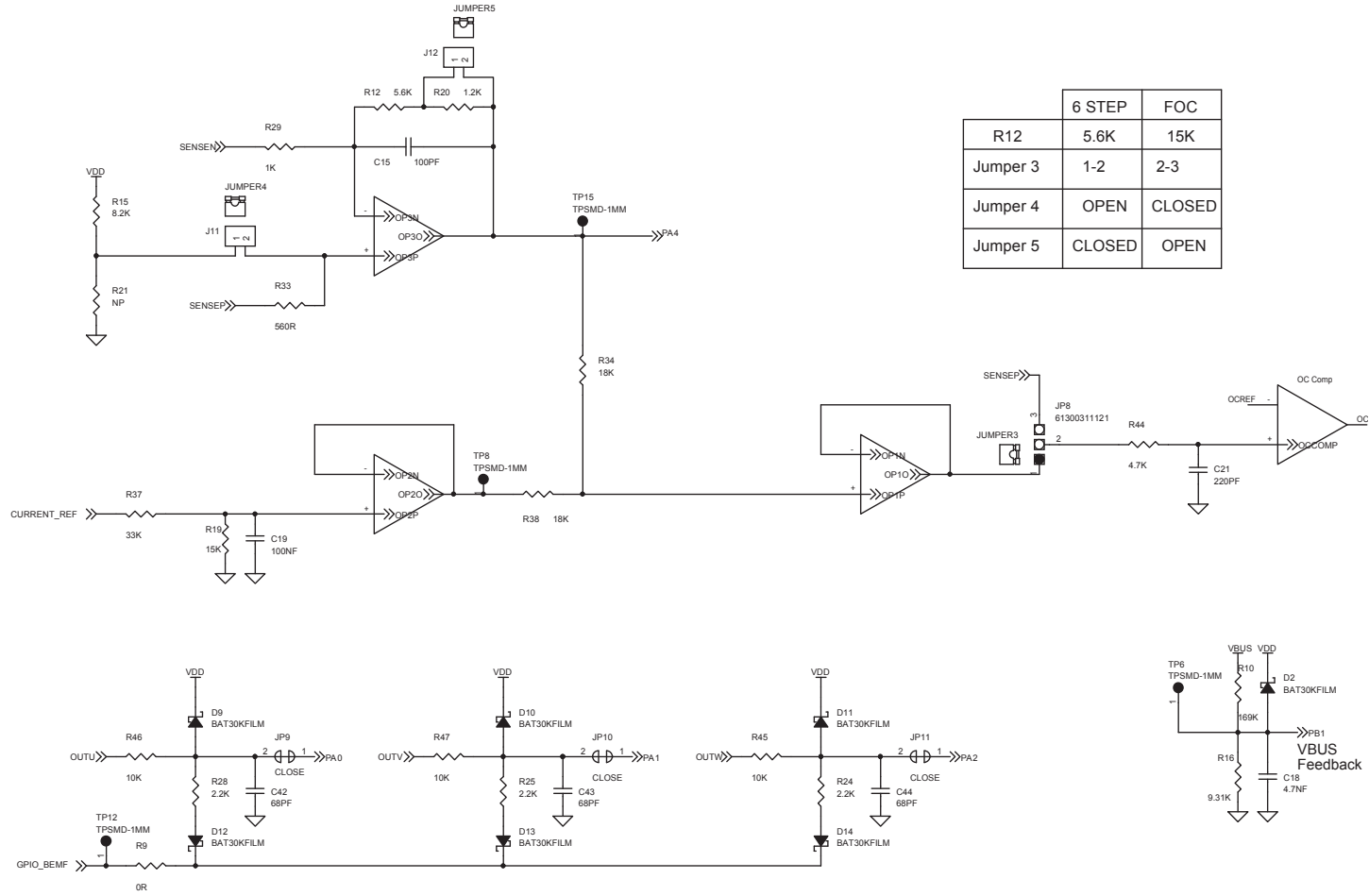

Figure 5. STEVAL-SPIN3202 schematic (3 of 4)



4 Bill of materials

Table 5. STEVAL-SPIN3202 bill of materials

Item	Q.ty	Ref.	Part/Value	Description	Manufacturer	Order code
1	15	C1, C5, C7, C8, C9, C11, C19, C20, C26, C27, C28, C29, C33, C34, C37	100nF 50V ±15% 603	Ceramic capacitors	Any	Any
2	1	C2	22µF 63V ±20% L8.3_W8.3_H9.5	Aluminium capacitor	PANASONIC	EEEFK1J220P
3	4	C3, C25, C40, C41	220nF 100V ±15% 805	Ceramic capacitors	Any	Any
4	1	C4	10µF 25V ±20% D4_H5.5	Aluminium capacitor	WURTH	865080440002
5	1	C6	3.3nF 50V ±15% 603	Ceramic capacitor	Any	Any
6	1	C10	47µF 6.3V ±20% 805	Ceramic capacitor	Any	Any
7	2	C12, C13	1 nF 50 V ±15% 603	Ceramic capacitors	Any	Any
8	2	C14, C18	4.7nF 50V ±15% 603	Ceramic capacitors	Any	Any
9	1	C15	100pF 50V ±15% 603	Ceramic capacitor	Any	Any
10	2	C16, C17	220µF 63V ±20% L13.5_W13.5_H15	Aluminium capacitors	PANASONIC	EEVFK1J221Q
11	1	C21	220pF 50V ±15% 603	Ceramic capacitor	Any	Any
12	5	C22, C23, C24, C35, C36	10pF 50V 0.1 603	Ceramic capacitors	Any	Any
13	2	C30, C31	1µF 10V ±15% 603	Ceramic capacitors	Any	Any
14	1	C32	10nF 50V ±15% 603	Ceramic capacitors	Any	Any
15	2	C38, C39	NP 63V ±20% D12.5_H22_P5	Aluminium capacitors	Any	Any
16	3	C42, C43, C44	68PF 50V ±15% 603	Ceramic capacitors	Any	Any
17	1	DL1	RED 603	LED	WURTH	150060RS75000
18	1	DL2	RED 805	LED	WURTH	150080RS75000
19	2	DL3, DL4	YELLOW 603	LED	WURTH	150060YS75000
20	1	D1	STPS0560Z SOD123	60 V, 0.5 A power Schottky rectifier	ST	STPS0560Z
21	7	D2, D9, D10, D11, D12, D13, D14	BAT30KFILM SOD523	30 V, 300 mA SMD general purpose signal Schottky diode	ST	BAT30KFILM

Item	Q.ty	Ref.	Part/Value	Description	Manufacturer	Order code
22	6	D3, D4, D5, D6, D7, D8	4148WS SOD323	Diodes	Any	Any
23	5	JP1, JP4, JP5, JP6, JP7	OPEN 805	Resistors	Any	Any
24	4	JP2, JP9, JP10, JP11	CLOSE 805	Resistors	Any	Any
25	2	JP3, JP8	61300311121	Headers	WURTH	61300311121
26	6	JUMPER1, JUMPER2, JUMPER3, JUMPER4, JUMPER5, JUMPER6	BLACK	Jumpers	WURTH	60900213621
27	2	J1, J2	691213510002	Screws	WURTH	691213510002
28	1	J3	691213510003	Screw	WURTH	691213510003
29	1	J4	61300511121	Header	WURTH	61300511121
30	1	J5	65100516121	USB	WURTH	65100516121
31	1	J6	61300411121	Header	WURTH	61300411121
32	5	J7, J8, J9, J11, J12	61300211121	Headers	WURTH	61300211121
33	1	J10	NP	Header	WURTH	61300211121
34	1	LD1	RED-GREEN PLCC4	LED	AVAGO	HSMF-A201-A00J1
35	1	L1	22µH 0.6A ±20% L3_W3_H1.5	Inductor	WURTH	744 040 322 20
36	1	M8	GX_3xx	PCB	Any	Any
37	2	N1, N2	NETS_L1_W0.5	Copper	Any	Any
38	6	Q1, Q2, Q3, Q4, Q5, Q6	N-MOS DPAK	N-channel 60 V, 0.0031 Ohm typ., 80 A STripFET F7 power MOSFET in a DPAK package	ST	STD140N6F7
39	1	Q7	NPN SOT23	CMS	ON SEMICONDUCTOR	BC847BL
40	1	R1	39K 1/10W ±5% 603	Resistor	Any	Any
41	7	R2, R7, R8, R62, R63, R67, R73	100R 1/10W ±5% 603	Resistors	Any	Any
42	1	R3	330R 1/10W ±5% 603	Resistor	Any	Any
43	2	R4, R5	120R 1/10W ±5% 603	Resistors	Any	Any
44	1	R6	100K 1/2W 0.1 L9.5_W4.9_H9.5	Trimmer	BOURNS	3386G-1-104-LF
45	6	R9, R14, R43, R50, R51, R52	0R 1/10W ±5% 603	Resistors	Any	Any
46	1	R10	169K 1/8W ±1% 805	Resistor	Any	Any
47	3	R11, R48, R49	680R 1/8W ±5% 805	Resistors	Any	Any

Item	Q.ty	Ref.	Part/Value	Description	Manufacturer	Order code
48	1	R12	5.6K 1/10W ±5% 603	Resistor	Any	Any
49	9	R13, R45, R46, R47, R53, R54, R55, R65, R71	10K 1/10W ±5% 603	Resistors	Any	Any
50	1	R15	8.2K 1/10W ±5% 603	Resistor	Any	Any
51	1	R16	9.31K 1/8W ±1% 805	Resistor	Any	Any
52	6	R17, R22, R31, R35, R39, R41	10R 1/10W ±5% 603	Resistors	Any	Any
53	6	R18, R23, R32, R36, R40, R42	62R 1/10W ±5% 603	Resistors	Any	Any
54	1	R19	15K 1/10W ±5% 603	Resistor	Any	Any
55	1	R20	1.2K 1/10W ±5% 603	Resistor	Any	Any
56	5	R21, R59, R60, R61, R72	NP 603	Resistors	Any	Any
57	3	R24, R25, R28	2.2K 1/10W ±5% 603	Resistors	Any	Any
58	2	R26, R27	0.02R 2W ±5% 2512	Resistors	Any	Any
59	4	R29, R56, R57, R58	1K 1/10W ±5% 603	Resistors	Any	Any
60	2	R30, R70	100K 1/10W ±5% 603	Resistors	Any	Any
61	1	R33	560R 1/10W ±5% 603	Resistor	Any	Any
62	2	R34, R38	18K 1/10W ±5% 603	Resistors	Any	Any
63	1	R37	33K 1/10W ±5% 603	Resistor	Any	Any
64	4	R44, R69, R74, R75	4.7K 1/10W ±5% 603	Resistors	Any	Any
65	1	R64	1.5K 1/10W ±5% 603	Resistor	Any	Any
66	1	R66	36K 1/10W ±5% 603	Resistor	Any	Any
67	1	R68	2.7K 1/10W ±5% 603	Resistor	Any	Any
68	3	SW1, SW2, SW3	430483025816 L6.2_W6.2_H2.5	Switches	WURTH	430483025816
69	10	TP1, TP2, TP3, TP4, TP5, TP7, TP10, TP11, TP13, TP14	S1751-46R	Test points	HARWIN	S1751-46R
70	5	TP6, TP8, TP9, TP12, TP15	TPSMD-1MM	Test points	Any	Any
71	2	TP16, TP17	NEEDLE-PAD-1.7mm	Test points	Any	Any
72	1	U1	STSPIN32F0A VFQFPN48_L7_W7_P.5	Advanced BLDC controller with embedded STM32 MCU	ST	STSPIN32F0A

Item	Q.ty	Ref.	Part/Value	Description	Manufacturer	Order code
73	1	U2	USBLC6-2SC6 SOT23-6L	ESD protection for high speed USB 2.0	ST	USBLC6-2SC6
74	1	U3	LD3985M33R SOT23-5	Ultra low drop- low noise BiCMOS voltage regulators low ESR capacitors compatible	ST	LD3985M33R
75	1	U4	STM32F103CBT6 LQFP48	Mainstream performance line, Arm Cortex-M3 MCU with 128 Kbytes of Flash memory, 72 MHz CPU, motor control, USB and CAN	ST	STM32F103CBT6
76	1	X1	8MHz L3.2_W2.5	Quartz	NDK	NX3225GD 8MHz EXS00A-CG04874

Revision history

Table 6. Document revision history

Date	Revision	Changes
26-Sep-2017	1	Initial release
21-Jul-2021	2	Updated Section 1 Hardware and software requirements and Section 2 Getting started. Minor text changes.
20-Sep-2022	3	Updated Section 2.1 Hardware description and configuration, Section 2.2.1 Six-step/FOC selection, and Section 3 Schematic diagrams.

IMPORTANT NOTICE – READ CAREFULLY

STMicroelectronics NV and its subsidiaries (“ST”) reserve the right to make changes, corrections, enhancements, modifications, and improvements to ST products and/or to this document at any time without notice. Purchasers should obtain the latest relevant information on ST products before placing orders. ST products are sold pursuant to ST’s terms and conditions of sale in place at the time of order acknowledgment.

Purchasers are solely responsible for the choice, selection, and use of ST products and ST assumes no liability for application assistance or the design of purchasers’ products.

No license, express or implied, to any intellectual property right is granted by ST herein.

Resale of ST products with provisions different from the information set forth herein shall void any warranty granted by ST for such product.

ST and the ST logo are trademarks of ST. For additional information about ST trademarks, refer to www.st.com/trademarks. All other product or service names are the property of their respective owners.

Information in this document supersedes and replaces information previously supplied in any prior versions of this document.

© 2022 STMicroelectronics – All rights reserved