

May.1.2023 Copyright 2023 HIROSE ELECTRIC CO., LTD. All Rights Reserved.  
In case of consideration for using Automotive equipment / device which demand high reliability, kindly contact our sales window correspondents.

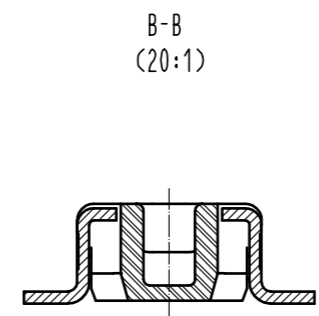

HRS DRAWING FOR REFERENCE

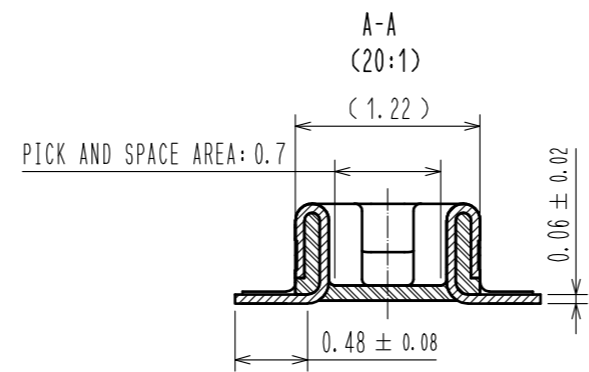
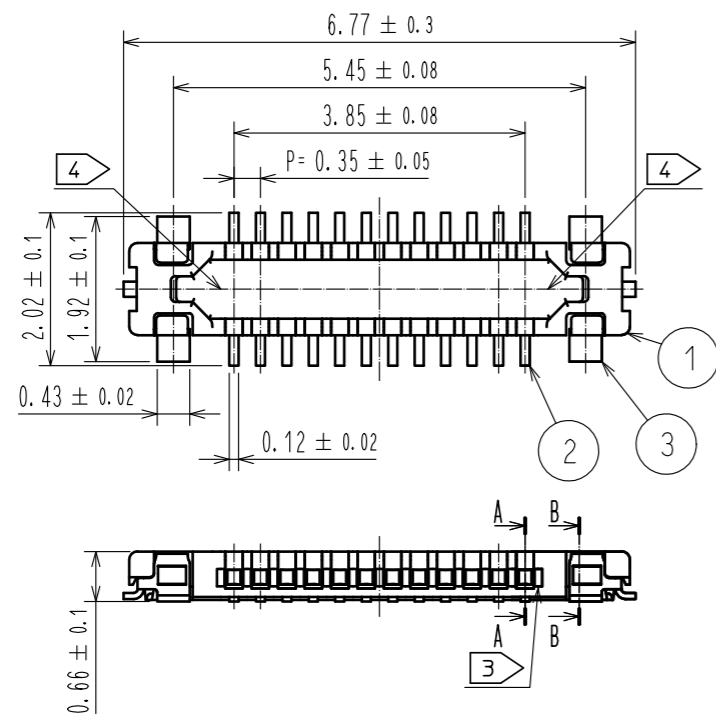
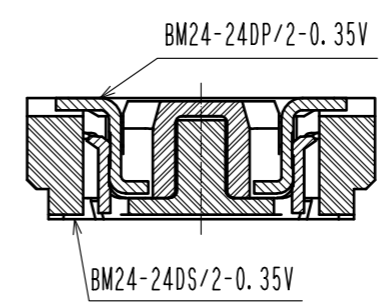
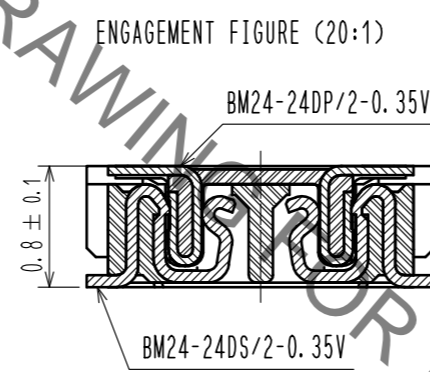

- NOTE 1 . ALL LEAD CO-PLANARITY SHALL BE 0.08mm MAX.
- 2 CONTACT PLATING SPECIFICATIONS  
CONTACT AREA : GOLD 0.05 μm MIN  
SMT LEAD : GOLD 0.05 μm MIN  
UNDER PLATING : NICKEL 1 μm MIN  
( SURFACE : SEALING )
  - 3 A PART OF THE WALL COULD BE NOTCHED.
  - 4 HRS MARK AND CAV No. ARE INDICATED IN APPROX. POSITION SHOWN.

◆RECOMMENDED PCB LAYOUT

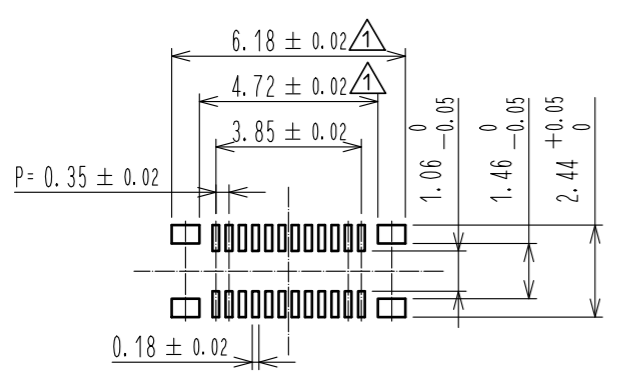

◆RECOMMENDED METAL MASK DIMENSIONS  
METAL MASK THICKNESS : 100 μm

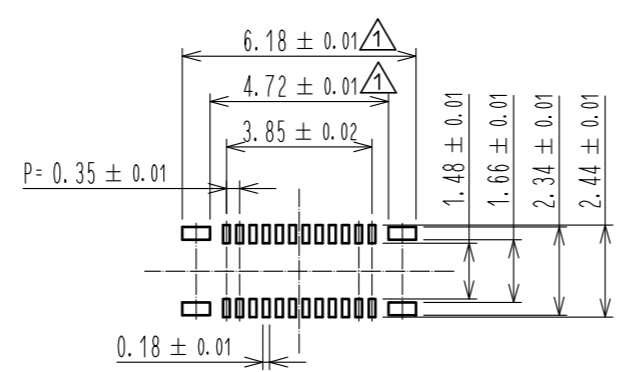

5 RECOMMENDED REFLOW TEMPERATURE PROFILE USING LEAD-FREE SOLDER PASTE.

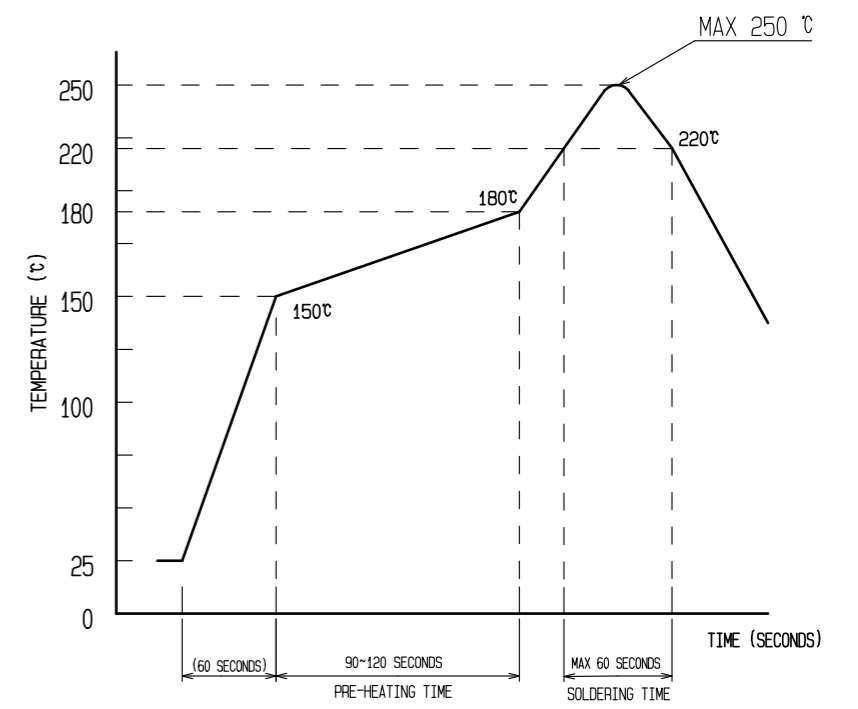

- REFLOW METHOD: IR REFLOW  
NUMBER OF REFLOW CYCLES: 2 CYCLES MAX.
- 1) REFLOW TIME  
DURATION ABOVE 220°C, 60 SEC MAX.  
(PEAK TEMPERATURE: 250°C MAX)
  - 2) PRE-HEAT TIME  
PRE-HEAT TEMPERATURE(MIN): 150°C  
PRE-HEAT TEMPERATURE(MAX): 180°C  
PRE-HEAT TIME: 90-120 SEC.

- 5 THIS TEMPERATURE PROFILE IS PER THE CONDITIONS SHOWN ABOVE. ADDITIONAL FACTORS, SUCH AS SOLDER PASTE TYPE, PCB SIZE AND OTHER MOUNTED COMPONENTS COULD AFFECT THE PROFILE. THEREFORE, A THOROUGH EVALUATION OF MOUNTING COONDITION IS REQUIRED PRIOR TO PRODUCTION. TEPERATURE IS MEASURED AT CONTACT LEAD.
6. PLEASE CONTACT US IN CASE YOU WILL MAKE DIFFERENT SETTINGS FROM OUR RECOMMENDATION.

4	PS	CLEAR(EMBOSSED CARRIER TAPE)					
3	COPPER ALLOY		7	PS	CLEAR (REINFORCEMENT COLLAR)		
2	COPPER ALLOY		6	PS	BLACK (PLASTIC REEL)		
1	LCP	UL94 V-0. BLACK	5	POLYESTER	CLEAR (COVER TAPE)		
NO.	MATERIAL	FINISH . REMARKS	NO.	MATERIAL	FINISH . REMARKS		
UNITS mm		SCALE 10 : 1	COUNT 4	DESCRIPTION OF REVISIONS DIS-H-00001151	DESIGNED NY. YAMASHIRO	CHECKED TS. MIYAZAKI	DATE 15. 12. 03
<b>HRS</b> HIROSE ELECTRIC CO., LTD.		APPROVED : KH. IKEDA	14. 04. 04	DRAWING NO. EDC3-353451-01			
		CHECED : WR. FUKUCHI	14. 04. 04	PART NO. BM24-24DP/2-0.35V(51)			
		DESIGNED : YH. HASEGAWA	14. 04. 04	CODE NO. CL677-2005-0-51			
		DRAWN : YH. HASEGAWA	14. 04. 04	1/2			

May.1.2023 Copyright 2023 HIROSE ELECTRIC CO., LTD. All Rights Reserved.  
In case of consideration for using Automotive equipment / device which demand high reliability, kindly contact our sales window correspondents.

EMBOSSED CARRIER TAPE PACKAGING (FREE)

STYLE AND DIMENTION OF REEL (FREE)

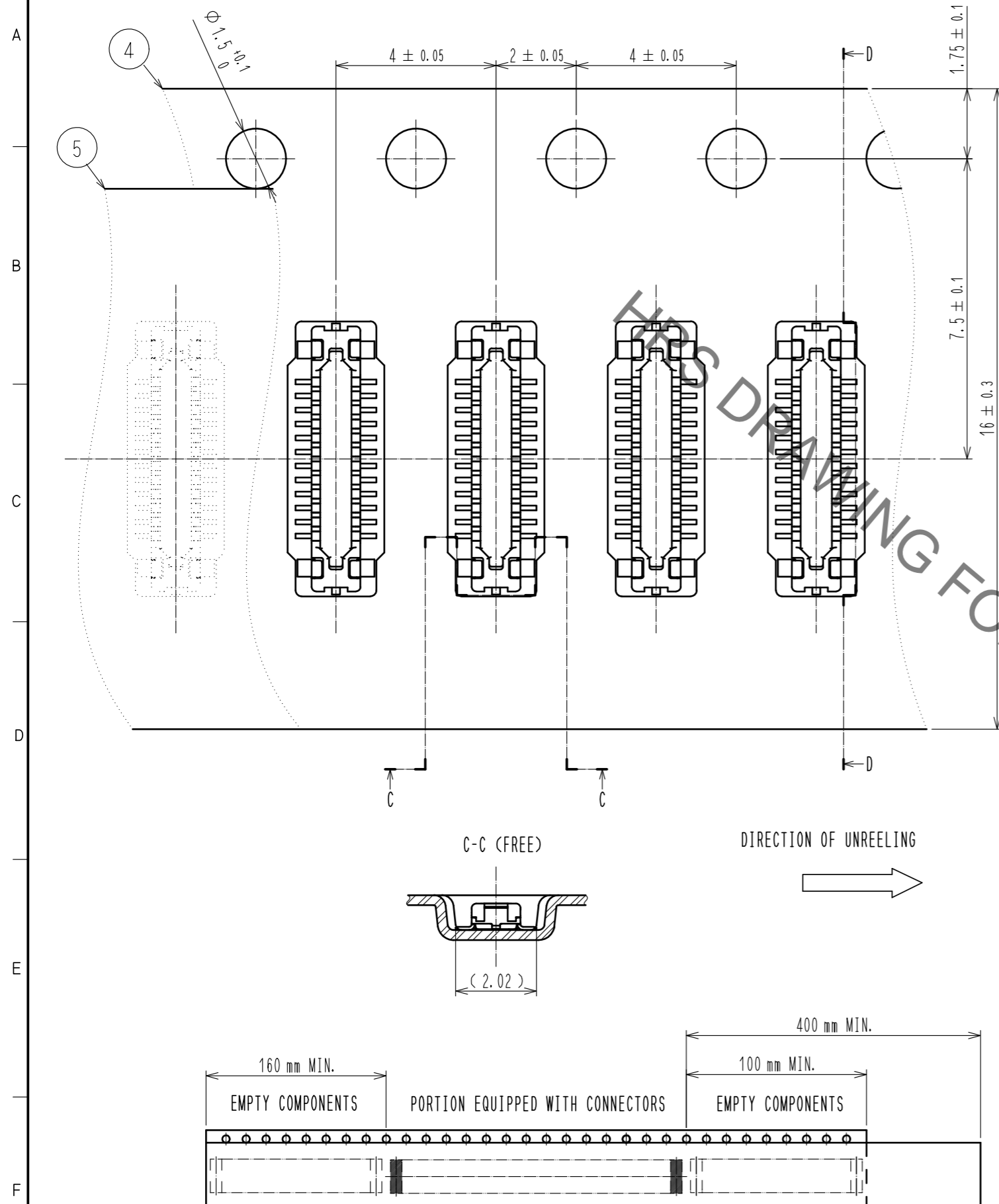

D-D (FREE)

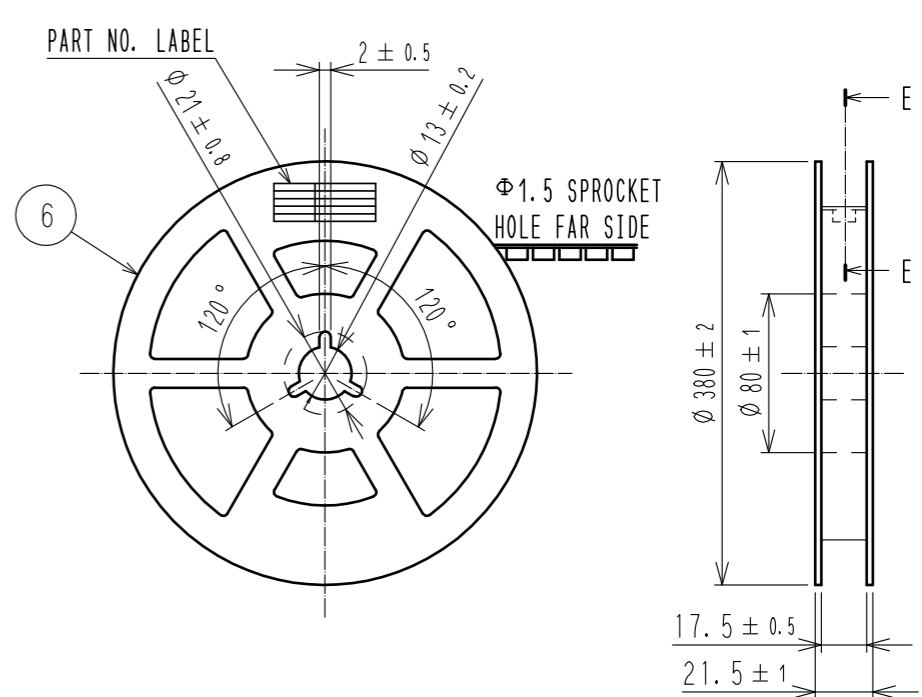

E-E (FREE)

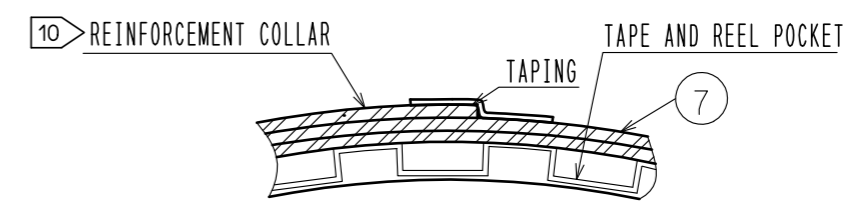

DETAIL OF PART NO. LABEL

製造年月日	** ** *	DATA OF MANUFACTURED
製品コード	CL0677-2005-0(51)	CODE NO.
製品名	BM24-24DP/2-0.35V(51)	PART NO.
数量	10,000	QUANTITY
納入者	ヒロセ電機(株)	SUPPLIER

- 7 . PER REEL 10,000 CONNECTORS.
- 8 . THE DIMENSIONS IN PARENTHESES ARE FOR REFERENCE.
- 9 . REFER TO JIS C 0806(PACKAGING OF COMPONENTS FOR AUTOMATIC HANDLING)
- 10 . AFTER PACKAGING, ROLL 2 METERS OF THE REINFORCEMENT COLLAR TO OUTER CIRCUMFERENCE OF TAPE AND REEL POCKET. AND TAPE DOWN AT THE END THE COLLAR.

<b>HRS</b>	DRAWING NO.	EDC3-353451-01
	PART NO.	BM24-24DP/2-0.35V(51)
	CODE NO.	CL677-2005-0-51
		$\triangle$ 2/2