

Description

Four pole switch or three pole switch/thermal circuit breaker (S-type TO CBE to EN 60934) with trip-free mechanism and red/green two button operation. Designed for snap-in panel mounting. Integral splash water protection to meet protection degree IP 66 in the operating area (option). Optional with under voltage release module. Complies with CBE standard EN 60934 (IEC 60934).

Typical applications

High-pressure cleaners, shredders, pumps, power saws, electric tools, motors, processing systems.

Approval logos



Conformity



3140

Technical data

For further details please see: http://www.e-t-a.de/ti_e

Voltage rating	3 AC 415 V		
Current rating range	0.1...16 A		
Typical life	3-pole		
	3 AC 415 V: 0.1...14 A 15...16 A	10,000 operations at 1 x I _N , inductive 10,000 operations at 1 x I _N , resistive	
3 AC 415 V	4-pole		
	0.1...14 A 15...16 A	10,000 operations at 1 x I _N , inductive 10,000 operations at 1 x I _N , resistive	
Ambient temperature	-30...+60 °C (-22...+140 °F)		
Insulation co-ordination (IEC 60664 and 60664A)	rated impulse withstand voltage	pollution degree 2	
	2.5 kV	reinforced insulation in operating area	
Dielectric strength (IEC 60664 and 60664A) operating area between poles (3-pole)	test voltage	AC 3,000 V AC 1,500 V	
	Insulation resistance	> 100 MΩ (DC 500 V)	
Interrupting capacity I _{cn}	0.1...2 A	10 x I _N	
	2.5...16 A	150 A	
Interrupting capacity (UL 1077)	I _N	U _N	3- and 4-pole
	0.1...16 A	AC 250 V	5,000 A
Degree of protection (IEC 60529/DIN 40050)	operating area IP40 (IP66 with water splash protection) terminal area IP00		
Vibration	5 g (57-500 Hz) ± 0.38 mm (10-57 Hz) to IEC 60068-2-6, test Fc, 10 frequency cycles/axis		
Shock	20 g (11 ms) to IEC 60068-2-27, test Ea		
Corrosion	96 hours at 5 % salt mist, to IEC 60068-2-11, test Ka		
Humidity	240 hours at 95 % RH, to IEC 60068-2-78, test Cab		
Mass	approx. 68		

Approvals

Prüfstelle	Prüfnorm	Nennspannung	Nennstrombereich
UL	UL1077	AC 250 V DC 50 V	0,1...16 A (3-4 pole)
VDE	IEC/EN 60934	3 AC 415 V	0,1 A...16 A (3-4 pole)
CQC	GB 17701	AC 240/415 V	0,1 A...16 A (3-4 pole)
CSA	CSA C22.2, No. 235	AC 250 V DC 50 V	0,1 A...16 A (3-4 pole)

Standard current ratings and typical internal resistance values

Current rating (A)	Internal resistance per pole (Ω)	Current rating (A)	Internal resistance per pole (Ω)
0.1	94	3.5	0.0595
0.2	24	4	0.0435
0.3	12	4.5	0.0325
0.4	5.30	5	0.0325
0.5	4.20	6	0.0215
0.6	2.90	7	0.0165
0.8	1.50	8	0.0125
1	0.9	10	< 0.02
1.2	0.80	12	< 0.02
1.5	0.45	14	< 0.02
2	0.27	15	< 0.02
2.5	0.0785	16	< 0.02
3	0.0595		

Ordering information

Type No.

3140 four pole switch or three pole switch/circuit breaker

Mounting

F snap in frame

Frame

1 standard

2 splash water protected version

Number of poles

3 3-pole, thermally protected

7 4-pole, thermally protected on 3 poles only

Frame mounting

0 panel thickness 1-6.35 mm (.04-.25 in)

Terminal design

P7 blade terminals 2x2.8x0.8 mm (QC 2x.110), DIN 46244-C

H7 as P7, additionally flat-head screw ISO 7045-M3.5 with +/- slot at terminal .1 (required with X3140-U)

Characteristic curve

T1 thermal

Switch style

S 2 push buttons (ON/OFF)

Switch colour

GRX green/red

Current rating range

0.1...16 A

3140 - F 1 3 0 - P7 T1 - S GRX - 10 A ordering example

Please be informed that we have minimum ordering quantities to be observed.

All dimensions without tolerances are for reference only. In the interest of improved design, performance and cost effectiveness the right to make changes in these specifications without notice is reserved. Product markings may not be exactly as the ordering codes. Errors and omissions excepted.

Dimensions

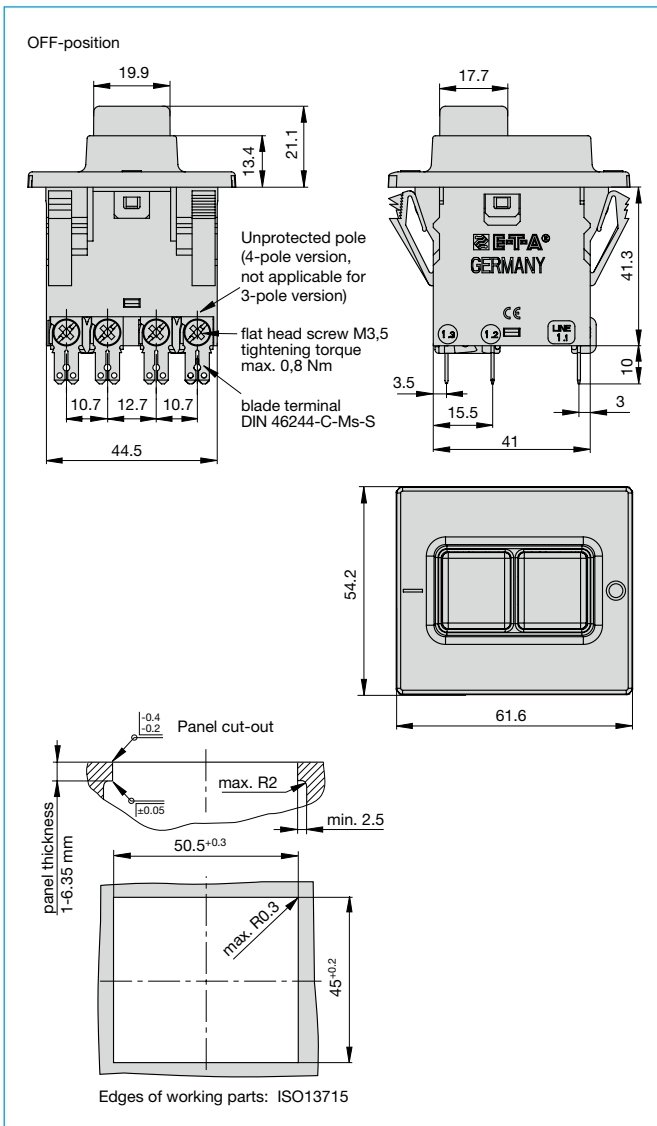

Installation drawing

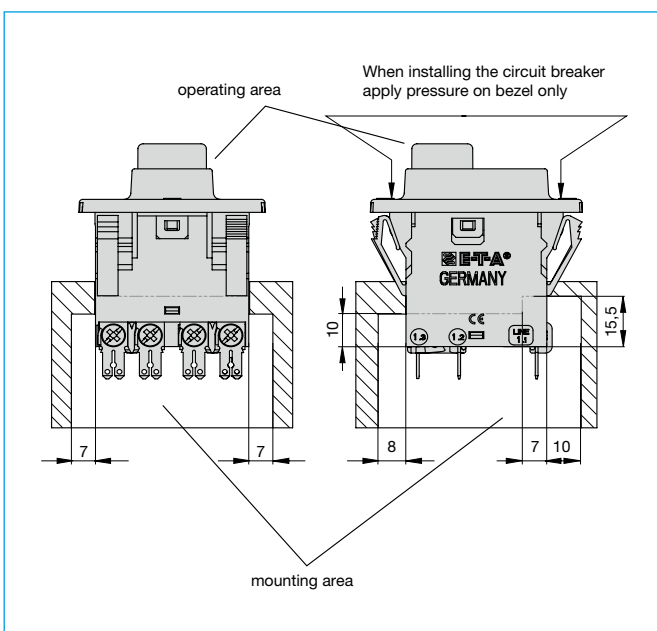

Internal connection diagrams

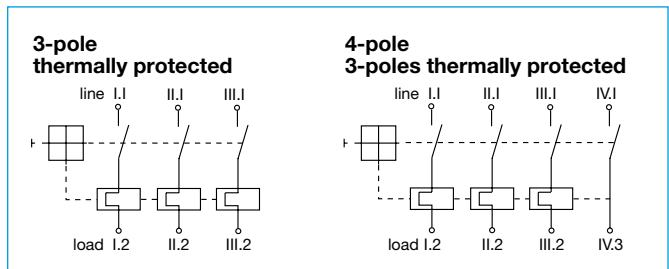

Typical time/current characteristics

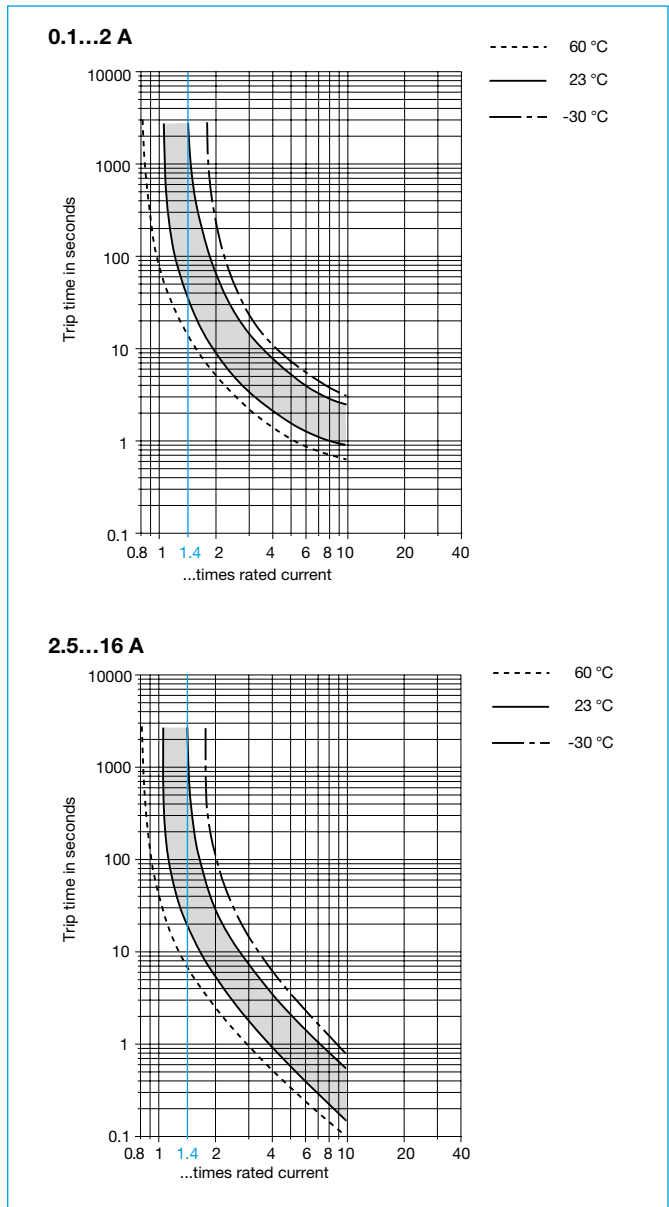

The time/current characteristic curve depends on the ambient temperature prevailing. In order to eliminate nuisance tripping, please multiply the circuit breaker current ratings by the derating factor shown below. See also section Technical information.

Ambient temp. °F	-22	-4	+14	+32	+73.4	+104	+122	+140
°C	-30	-20	-10	0	+23	+40	+50	+60
Derating factor	0.8	0.76	0.84	0.92	1	1.08	1.16	1.24

This is a metric design and millimeter dimensions take precedence (mm / inch)

Description

A module suitable for all versions of type 3140 to trip the main switch/circuit breaker mechanism in the event of loss of voltage of the connected phases. When the voltage is restored the switch must be reset to reconnect the load, thereby avoiding the safety hazards associated with automatic re-starting of machinery.

Note: Basic unit 3140-... must be fitted with -H7 or -G7 screw terminals.

US patent number: US 6,714,396 B2

Typical applications

Machines such as power tools, industrial equipment and domestic appliances where automatic restart after restoration of power could be dangerous (EU Machinery Directive).

Ordering information

Type No.	
X3140	Module for type 3140
Function	
U	undervoltage release module
Terminal design	
00	standard (without separate connections)
01	one blade terminal 2.8x0.8 (QC .110)
Voltage ratings	
00	AC 400 V 50/60 Hz
03	DC 24 V
09	AC 230 / 240 V 50/60 Hz
Assembly status	
M	module mounted to the circuit breaker
X3140 - U 00 00 M	ordering example

Technical data

Voltage ratings	AC 400 V 50/60 Hz; AC 230 V; DC 24 V
Voltage tolerance	+10%/-15%
Current consumption	approx. 2.0 mA
Release values	$0.2 \times U_N < U < 0.7 \times U_N$ (at a rated voltage of AC 400 V the device may release at 280 V and must release at 80 V)
Release delay	$t < 20 \text{ ms}$
Latch-in values	$\geq 85 \% U_N$
Ambient temperature	-30...+60 °C (-22...+140 °F)
Vibration	5 g (57-500 Hz) \pm 0.38 mm (10-57 Hz) to IEC 60068-2-6, test Fc 10 frequency cycles/axis
Shock	20 g (11 ms) to IEC 60068-2-27, test Ea
Corrosion	48 hours at 5 % salt mist, to IEC 60068-2-11, test Ka
Humidity	240 hours at 95 % RH to IEC 60068-2-78, test Cab
Mass	approx. 90 g (complete assembly)

Dimensions

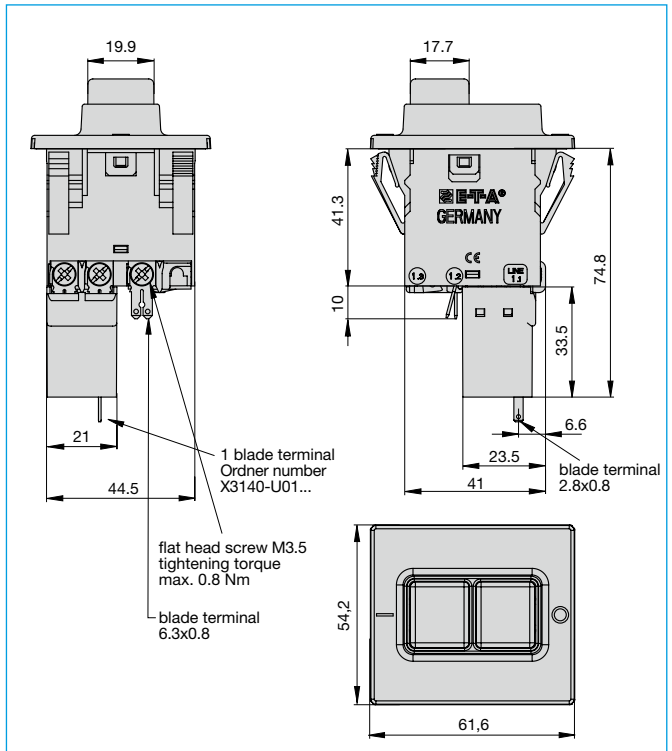

Internal connection diagrams

X3140-U00

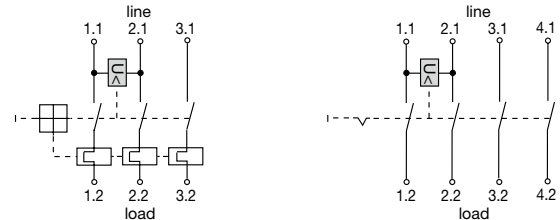

X3140-U01

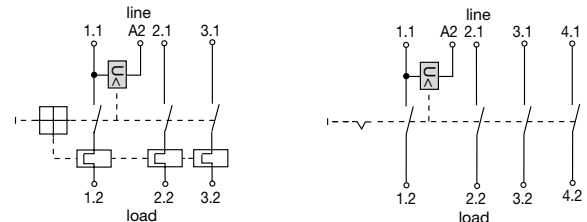

Approvals (complete circuit breaker/module assembly)

Authority	Standard	Rated voltage
VDE	IEC/EN 60934	AC 42...400 V DC 24 V

This is a metric design and millimeter dimensions take precedence ($\frac{\text{mm}}{\text{inch}}$)

All dimensions without tolerances are for reference only. In the interest of improved design, performance and cost effectiveness the right to make changes in these specifications without notice is reserved. Product markings may not be exactly as the ordering codes. Errors and omissions excepted.