

# WLS27 LED Strip Light



## Instruction Manual

Banner's WLS27 LED Strip Light has a sturdy aluminum housing and is encased in a shatterproof, UV-stabilized, copolyester shell, making it ideal for harsh indoor and outdoor applications.

- Low-profile, space-saving design
- Rugged, water-resistant IP69K option
- Available in eight lengths from 145 mm to 1130 mm
- Daisy chain power to multiple lights
- Optional snap clips for easy installation and repositioning
- Capability to dim lights using the wiring pinout (Hi/Lo/Off)
- Automatic temperature protection built into the unit. Above 50 °C, the light dims to manage heat and protect product lifetime

Figure 1. Stand-Alone Light or End Light in a Cascade—QD



Figure 2. First or Middle of a Cascade—QD



These Work Light Strips are available as either stand-alone models, or as cascade models that can be "daisy-chained" together for a continuous length of lighting, with a minimum of wiring.

Stand-alone models have a male quick disconnect (QD) at one end for power connection and no connections at opposite end. A stand-alone model may be used as the last in the cascade series.

Cascade models have a male quick disconnect (QD) at one end for power connection, and a female QD at the opposite end for connecting to other lights in the cascade. A double-ended accessory cordset must be used between each pair of lights in a cascade.

Use single-ended cordsets between the power source and the QD connection of a stand-alone light or the first light in a cascade. Use double-ended cordsets between lights in a cascade.



**Important:** Read the following instructions before operating the light. Please download the complete WLS27 LED Strip Light technical documentation, available in multiple languages, from [www.bannerengineering.com](http://www.bannerengineering.com) for details on the proper use, applications, Warnings, and installation instructions of this device.



**Important:** Lea el siguiente instructivo antes de operar el luminario. Por favor descargue desde [www.bannerengineering.com](http://www.bannerengineering.com) toda la documentación técnica de los WLS27 LED Strip Light, disponibles en múltiples idiomas, para detalles del uso adecuado, aplicaciones, advertencias, y las instrucciones de instalación de estos dispositivos.



**Important:** Lisez les instructions suivantes avant d'utiliser le luminaire. Veuillez télécharger la documentation technique complète des WLS27 LED Strip Light sur notre site [www.bannerengineering.com](http://www.bannerengineering.com) pour les détails sur leur utilisation correcte, les applications, les notes de sécurité et les instructions de montage.

## Models

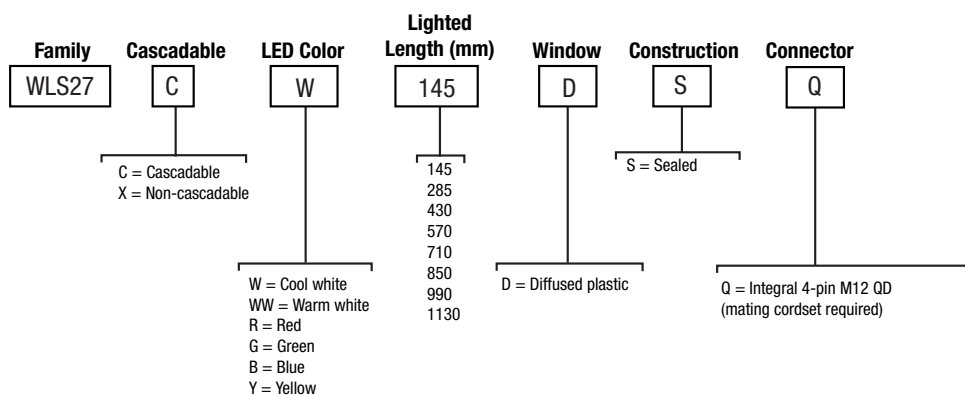

Models		Lighted Length	Power Connector
Stand-Alone	Cascade		
WLS27XW145DSQ	WLS27CW145DSQ	145 mm	Integral 4-pin M12 male quick-disconnect connector
WLS27XW285DSQ	WLS27CW285DSQ	285 mm	
WLS27XW430DSQ	WLS27CW430DSQ	430 mm	
WLS27XW570DSQ	WLS27CW570DSQ	570 mm	
WLS27XW710DSQ	WLS27CW710DSQ	710 mm	
WLS27XW850DSQ	WLS27CW850DSQ	850 mm	
WLS27XW990DSQ	WLS27CW990DSQ	990 mm	
WLS27XW1130DSQ	WLS27CW1130DSQ	1130 mm	



## Specifications

### Supply Voltage

12 to 30 V DC

Use only with a suitable Class 2 power supply (UL) or SELV power supply (CE)  
See electrical characteristics on product label

Light Length	Typical Current			Max. Current	Lumens (Typical at 25 °C)					
	12 V DC	24 V DC	30 V DC	A	Cool White	Warm White	Green	Red	Yellow	Blue
145 mm	0.33 A	0.15 A	0.12 A	0.4	400	400	180	55	50	40
285 mm	0.66 A	0.30 A	0.24 A	0.8	800	800	360	110	100	80
430 mm	1.01 A	0.46 A	0.36 A	1.2	1200	1200	540	165	150	120
570 mm	1.36 A	0.61 A	0.48 A	1.6	1600	1600	720	220	200	160
710 mm	1.75 A	0.77 A	0.60 A	2.0	2000	2000	900	275	250	200
850 mm	2.13 A	0.92 A	0.73 A	2.4	2400	2400	1080	330	300	240
990 mm	2.59 A	1.08 A	0.85 A	2.8	2800	2800	1260	385	350	280
1130 mm	3.04 A	1.24 A	0.97 A	3.2	3200	3200	1440	440	400	320

### Supply Protection Circuitry

Protected against reverse polarity and transient voltages

### Light Characteristics

Cool white

Color Temperature (CCT): 6500K (+500K, -400K)

Lumen output: 800 (± 5%) per foot, typical at 25 °C (77 °F)

Luminous efficacy: 110 lumens/Watt typical at 24 V DC at 25 °C (77 °F)

CRI: 85, typical

Warm white: 3000K (+200K, -100K)

Green: 525 nm

Red: 618 nm

Yellow: 590 nm

Blue: 460 nm

### Application Note

When connecting cascaded lights in series at 100% intensity, it is important not to exceed maximum current limitations:

Maximum length of light at 12 V DC: 1.4 m (4.6 ft)

Maximum length of light at 24 V DC: 3.0 m (9.8 ft)

Maximum length of light at 30 V DC: 3.1 m (10.2 ft)

At 50% intensity, double the lengths.



**Note:** Do not spray cable with high-pressure sprayer, or cable damage will result.

### LED Lifetime

Lumen Maintenance - L<sub>70</sub>

When operating within specifications, output will decrease less than 30% after 75,000 hours.

### Construction

Clear anodized aluminum housing; FDA-grade copolyester outer housing

### Mounting

Bracket LMBWLS27EC included (2 for lights up to 570 mm or 3 for lights 710 mm and longer)

### Connections

Integral 4-pin M12 male quick-disconnect connector (4-pin connecting cordset required)

### Environmental Rating

Rated IP66, IP67, and IP69K per DIN 40050-9

### Operating Temperature

-40 °C to +70 °C (-40 °F to +158 °F)

Light output begins to decrease above 50 °C (122 °F) and will be approximately 65% of max intensity at 60 °C (140 °F) and 30% of max intensity at 70 °C (158 °F)

### Storage Temperature

-40 °C to +70 °C (-40 °F to +158 °F)

### Vibration and Mechanical Shock

Vibration 10-55 Hz 1.0 mm p-p amplitude per IEC 60068-2-6

Shock 15G 11 ms duration, half sine wave per IEC 60068-2-27

### Certifications



**Banner Engineering BV** Park Lane, Culliganlaan 2F  
bus 3, 1831 Diegem, BELGIUM

**Turck Banner LTD** Blenheim House, Blenheim Court,  
Wickford, Essex SS11 8YT, Great Britain

## Performance

Optical data shown below is for cool white only. To get lux and candela values for other colors, multiply the values shown on the charts by the following factors:

<b>Warm White:</b>	1.000
<b>Green:</b>	0.450
<b>Red:</b>	0.138
<b>Yellow:</b>	0.125
<b>Blue:</b>	0.100

145 mm Models

Polar Candela Distribution

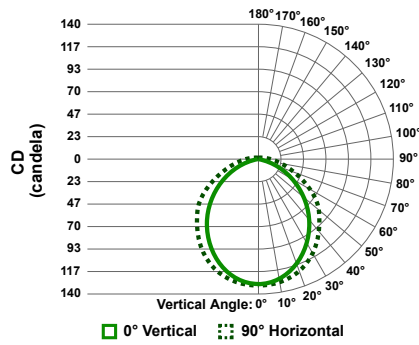

Isolux Pattern

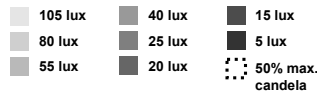
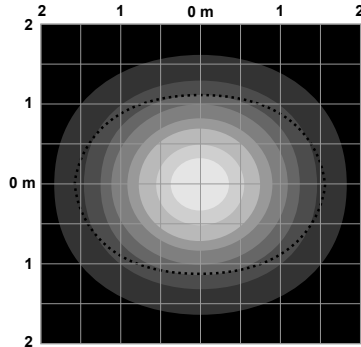

Illuminance at a Distance

	Center Beam (lux)	Beam Width (m)	
0.17 m	3644 lux	0.37 m	0.53 m
0.33 m	1099 lux	0.74 m	1.05 m
0.50 m	494 lux	1.11 m	1.59 m
0.67 m	280 lux	1.48 m	2.12 m
0.83 m	185 lux	1.85 m	2.64 m
1.00 m	129 lux	2.22 m	3.17 m

Vertical Spread: 95.1°  
Horizontal Spread: 115.0°

285 mm Models

Polar Candela Distribution

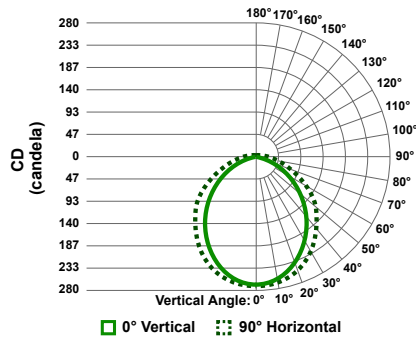

Isolux Pattern

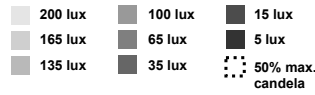
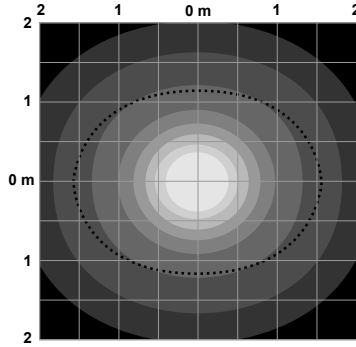

Illuminance at a Distance

	Center Beam (lux)	Beam Width (m)	
0.17 m	6280 lux	0.38 m	0.52 m
0.33 m	2256 lux	0.76 m	1.04 m
0.50 m	1066 lux	1.14 m	1.56 m
0.67 m	616 lux	1.53 m	2.09 m
0.83 m	409 lux	1.91 m	2.60 m
1.00 m	289 lux	2.29 m	3.12 m

Vertical Spread: 97.8°  
Horizontal Spread: 115.0°

430 mm Models

Polar Candela Distribution

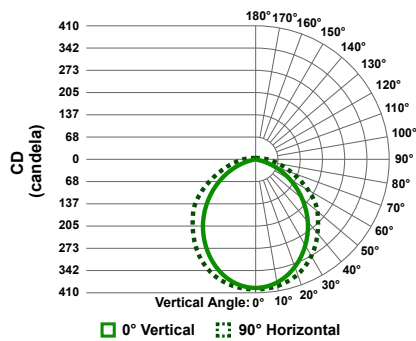

Isolux Pattern

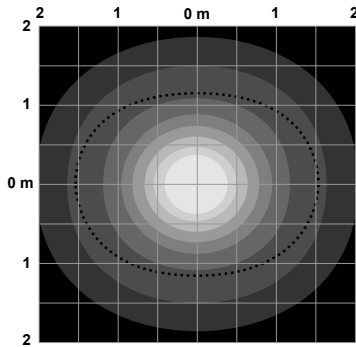

Illuminance at a Distance

	Center Beam (lux)	Beam Width (m)	
0.17 m	7280 lux	0.39 m	0.51 m
0.33 m	2996 lux	0.77 m	1.02 m
0.50 m	1516 lux	1.16 m	1.53 m
0.67 m	909 lux	1.54 m	2.05 m
0.83 m	610 lux	1.92 m	2.55 m
1.00 m	436 lux	2.31 m	3.07 m

Vertical Spread: 98.2°  
Horizontal Spread: 113.8°

570 mm Models

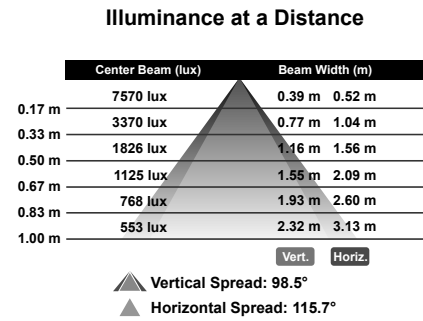
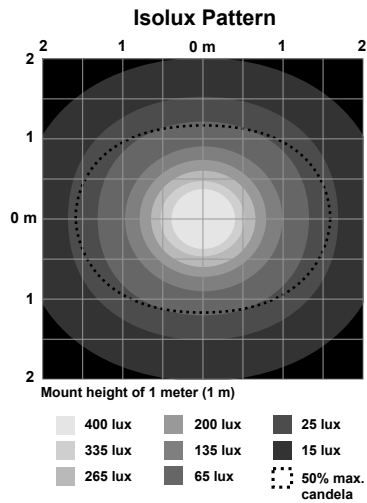
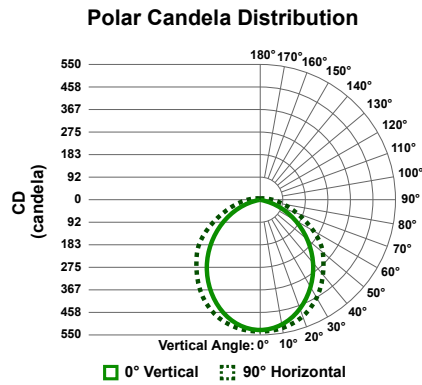

710 mm Models

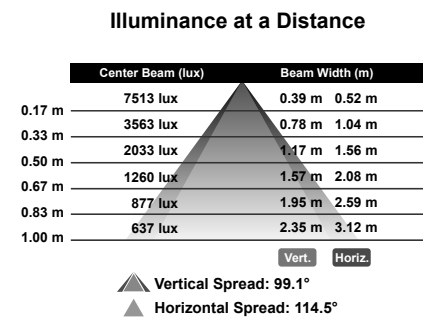
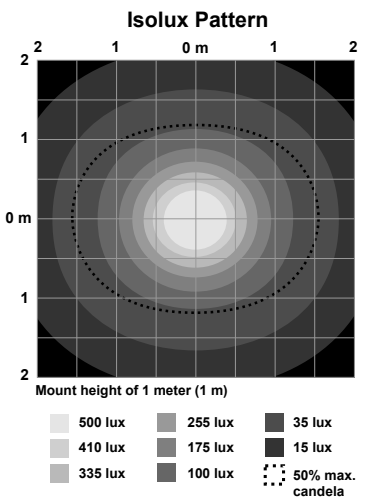
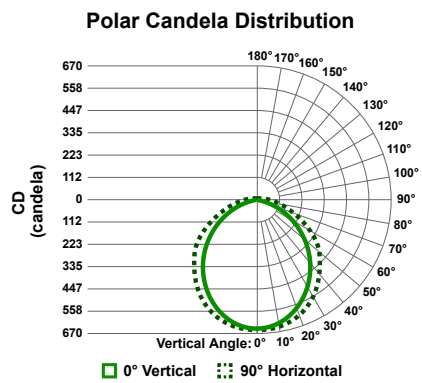

850 mm Models

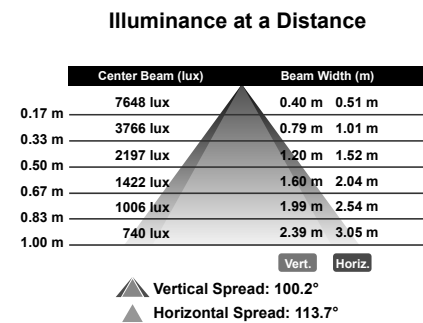
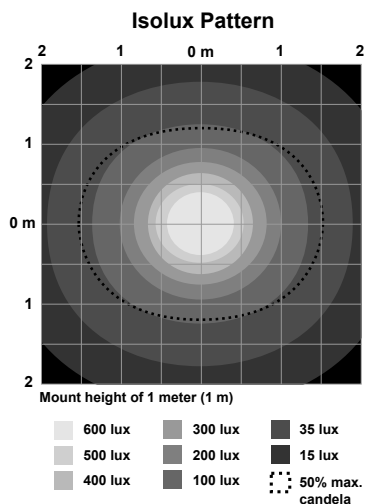
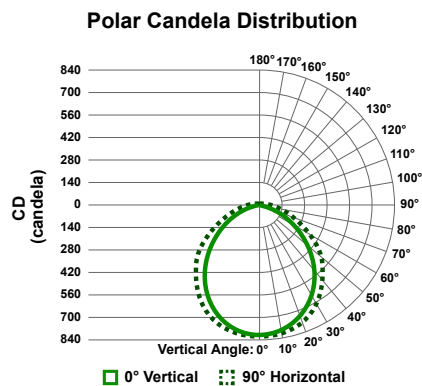

990 mm Models

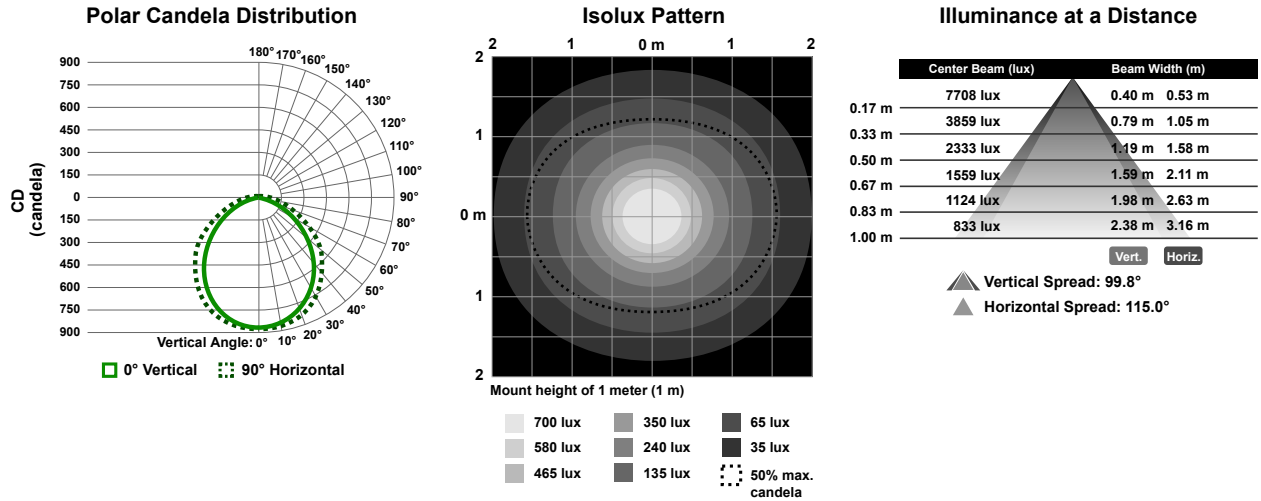

1130 mm Models

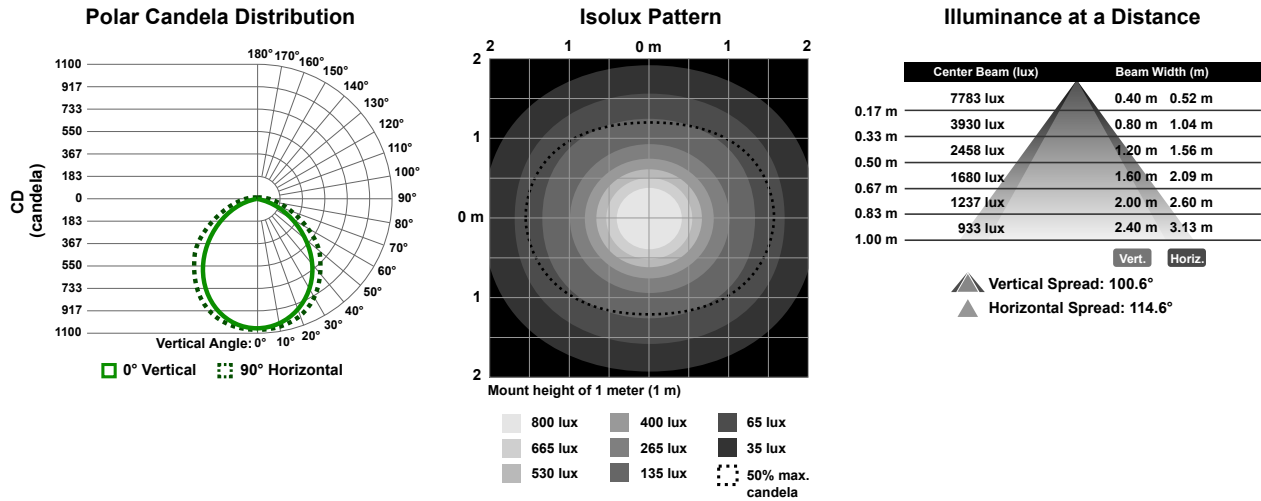

Dimensions

Figure 3. Quick Disconnect Models

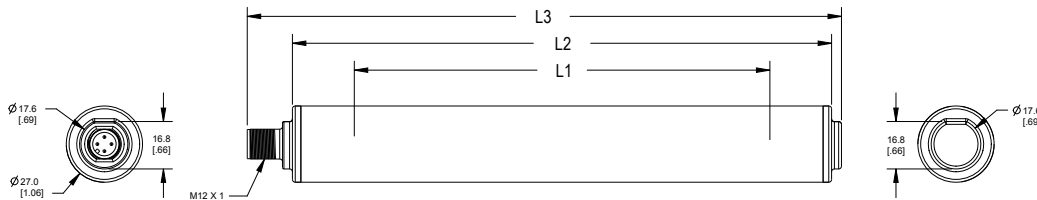
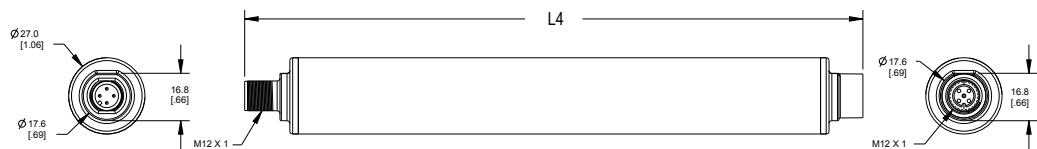

Figure 4. Cascade Models



Models	L1	L2	L3	L4
WLS27..145..	145 mm (5.7 in)	191 mm (7.5 in)	210.5 mm (8.3 in)	219 mm (8.6 in)
WLS27..285..	286 mm (11.3 in)	332 mm (13.1 in)	351.5 mm (13.8 in)	360 mm (14.2 in)
WLS27..430..	427 mm (16.8 in)	473 mm (18.6 in)	492.5 mm (19.4 in)	501 mm (19.7 in)

Models	L1	L2	L3	L4
WLS27..570..	568 mm (22.4 in)	614 mm (24.2 in)	633.5 mm (24.9 in)	642 mm (25.3 in)
WLS27..710..	709 mm (27.9 in)	755 mm (29.7 in)	774.5 mm (30.5 in)	783 mm (30.8 in)
WLS27..850..	850 mm (33.5 in)	896 mm (35.3 in)	915.5 mm (36 in)	924 mm (36.4 in)
WLS27..990..	991 mm (39 in)	1037 mm (40.8 in)	1056.5 mm (41.6 in)	1065 mm (41.9 in)
WLS27..1130..	1132 mm (44.6 in)	1178 mm (46.4 in)	1197.5 mm (47.1 in)	1206 mm (47.5 in)

## Wiring Diagram

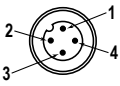
4-pin M12/Euro-style male QD	Pin	Wire Color	Connection
	1	brown	12 to 30 V DC
	3	blue	DC common
	4	black	Connect to 12 to 30 V DC for 50% maximum intensity. For maximum intensity, leave the black wire floating or connected to common
	2	white	Not used

## Accessories

### Cordsets

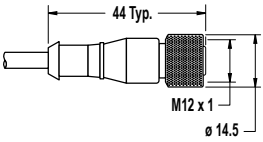
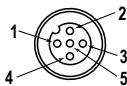
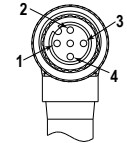
4-Pin Threaded M12 Cordsets—Single Ended					
Model	Length	Style	Dimensions	Pinout (Female)	
MQDC-406	2 m (6.56 ft)	Straight			1 = Brown 2 = White 3 = Blue 4 = Black 5 = Unused
MQDC-415	5 m (16.4 ft)				
MQDC-430	9 m (29.5 ft)				
MQDC-450	15 m (49.2 ft)	Right-Angle			
MQDC-406RA	2 m (6.56 ft)				
MQDC-415RA	5 m (16.4 ft)				
MQDC-430RA	9 m (29.5 ft)				
MQDC-450RA	15 m (49.2 ft)				

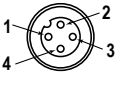
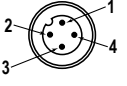
4-Pin Threaded M12 Cordsets—Double Ended					
Model	Length	Style	Dimensions	Pinout	
MQDEC-401SS	0.31 m (1 ft)	Male Straight/Female Straight		Female	
MQDEC-403SS	0.91 m (2.99 ft)				
MQDEC-406SS	1.83 m (6 ft)				
MQDEC-412SS	3.66 m (12 ft)				
MQDEC-420SS	6.10 m (20 ft)				
MQDEC-430SS	9.14 m (30.2 ft)				
MQDEC-450SS	15.2 m (49.9 ft)			Male	
					1 = Brown 2 = White 3 = Blue 4 = Black

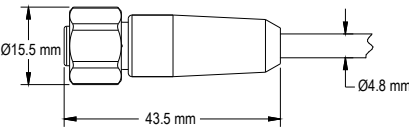
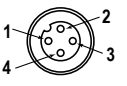
4-Pin Threaded M12 Cordsets—Washdown, Stainless Steel, Single Ended					
Model	Length	Style	Dimensions	Pinout (Female)	
MQDC-WDSS-0406	2 m (6.56 ft)	Straight			1 = Brown 2 = White 3 = Blue 4 = Black
MQDC-WDSS-0415	5 m (16.4 ft)				
MQDC-WDSS-0430	9 m (29.5 ft)				

4-Pin Threaded M12 Cordsets—Double Ended, Washdown, Stainless Steel				
Model	Length	Style	Dimensions	Pinout
MQDEC-WDSS-401SS	0.31 m (1 ft)	Male Straight/Female Straight		Female
MQDEC-WDSS-403SS	0.91 m (2.99 ft)			
MQDEC-WDSS-406SS	1.83 m (6 ft)			Male
MQDEC-WDSS-412SS	3.66 m (12 ft)			<p>1 = Brown 2 = White 3 = Blue 4 = Black</p>

4-Pin Threaded M12 Splitter Cordsets—Flat Junction			
Model	Branches (Female)	Trunk (Male)	Pinout
CSB-M1240M1240	No branch	No trunk	<p>Female</p> <p>Male</p> <p>1 = Brown 2 = White 3 = Blue 4 = Black</p>
CSB-M1240M1241	2 x 0.3 m (1 ft)	No trunk	
CSB-M1241M1241		0.30 m (1 ft)	
CSB-M1248M1241		2.44 m (8 ft)	
CSB-M12415M1241		4.57 m (15 ft)	
CSB-M12425M1241		7.60 m (25 ft)	
CSB-UNT425M1241		7.60 m (25.0 ft) Unterminated	

## Brackets

### LMBWLS27EC

- Clear copolyester
- Clearance for M5 or #10 hardware

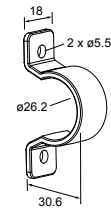

### LMBWLS27H

- 300 series stainless steel mounting brackets
- M4 stainless steel hardware included

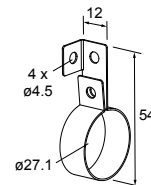

### LMBWLS27SP

- Clear copolyester
- Clearance for M5 or #10 hardware
- Snap bracket for light duty applications

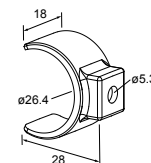

**LMBWLS27T**

- Stainless steel mounting brackets with rubber grips
- M5 stainless steel hardware included
- Clearance for M5 or #10 hardware

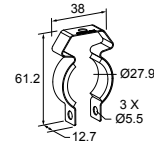
**LMBWLS27U**

- Clear copolyester
- Clearance for M5 or #10 hardware
- Clamps securely around the light body

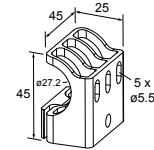

## Banner Engineering Corp. Limited Warranty

---

Banner Engineering Corp. warrants its products to be free from defects in material and workmanship for one year following the date of shipment. Banner Engineering Corp. will repair or replace, free of charge, any product of its manufacture which, at the time it is returned to the factory, is found to have been defective during the warranty period. This warranty does not cover damage or liability for misuse, abuse, or the improper application or installation of the Banner product.

**THIS LIMITED WARRANTY IS EXCLUSIVE AND IN LIEU OF ALL OTHER WARRANTIES WHETHER EXPRESS OR IMPLIED (INCLUDING, WITHOUT LIMITATION, ANY WARRANTY OF MERCHANTABILITY OR FITNESS FOR A PARTICULAR PURPOSE), AND WHETHER ARISING UNDER COURSE OF PERFORMANCE, COURSE OF DEALING OR TRADE USAGE.**

This Warranty is exclusive and limited to repair or, at the discretion of Banner Engineering Corp., replacement. **IN NO EVENT SHALL BANNER ENGINEERING CORP. BE LIABLE TO BUYER OR ANY OTHER PERSON OR ENTITY FOR ANY EXTRA COSTS, EXPENSES, LOSSES, LOSS OF PROFITS, OR ANY INCIDENTAL, CONSEQUENTIAL OR SPECIAL DAMAGES RESULTING FROM ANY PRODUCT DEFECT OR FROM THE USE OR INABILITY TO USE THE PRODUCT, WHETHER ARISING IN CONTRACT OR WARRANTY, STATUTE, TORT, STRICT LIABILITY, NEGLIGENCE, OR OTHERWISE.**

Banner Engineering Corp. reserves the right to change, modify or improve the design of the product without assuming any obligations or liabilities relating to any product previously manufactured by Banner Engineering Corp. Any misuse, abuse, or improper application or installation of this product or use of the product for personal protection applications when the product is identified as not intended for such purposes will void the product warranty. Any modifications to this product without prior express approval by Banner Engineering Corp will void the product warranties. All specifications published in this document are subject to change. Banner reserves the right to modify product specifications or update documentation at any time. Specifications and product information in English supersede that which is provided in any other language. For the most recent version of any documentation, refer to: [www.bannerengineering.com](http://www.bannerengineering.com).

For patent information, see [www.bannerengineering.com/patents](http://www.bannerengineering.com/patents).

## FCC Part 15 Class B

This equipment has been tested and found to comply with the limits for a Class B digital device, pursuant to part 15 of the FCC Rules. These limits are designed to provide reasonable protection against harmful interference in a residential installation. This equipment generates, uses and can radiate radio frequency energy and, if not installed and used in accordance with the instructions, may cause harmful interference to radio communications. However, there is no guarantee that interference will not occur in a particular installation. If this equipment does cause harmful interference to radio or television reception, which can be determined by turning the equipment off and on, the user is encouraged to try to correct the interference by one or more of the following measures:

- Reorient or relocate the receiving antenna.
- Increase the separation between the equipment and receiver.
- Connect the equipment into an outlet on a circuit different from that to which the receiver is connected.
- Consult the dealer or an experienced radio/TV technician for help.

## Industry Canada

This device complies with CAN ICES-3 (B)/NMB-3(B). Operation is subject to the following two conditions: 1) This device may not cause harmful interference; and 2) This device must accept any interference received, including interference that may cause undesired operation.

Cet appareil est conforme à la norme NMB-3(B). Le fonctionnement est soumis aux deux conditions suivantes : (1) ce dispositif ne peut pas occasionner d'interférences, et (2) il doit tolérer toute interférence, y compris celles susceptibles de provoquer un fonctionnement non souhaité du dispositif.

## Mexican Importer

Banner Engineering de México, S. de R.L. de C.V.  
David Alfaro Siqueiros 103 Piso 2 Valle oriente  
San Pedro Garza Garcia Nuevo Leon, C. P. 66269

81 8363.2714