

SEE DETAIL "A"

SECTION A-A

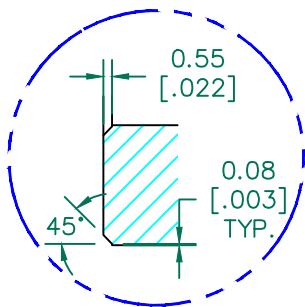

DETAIL A



IMPEDANCE (Z)			
Frequency	25 MHz	100 MHz	300 MHz
Nominal (REF)	160 Ω	307 Ω	440 Ω
Minimum	- Ω	229 Ω	- Ω

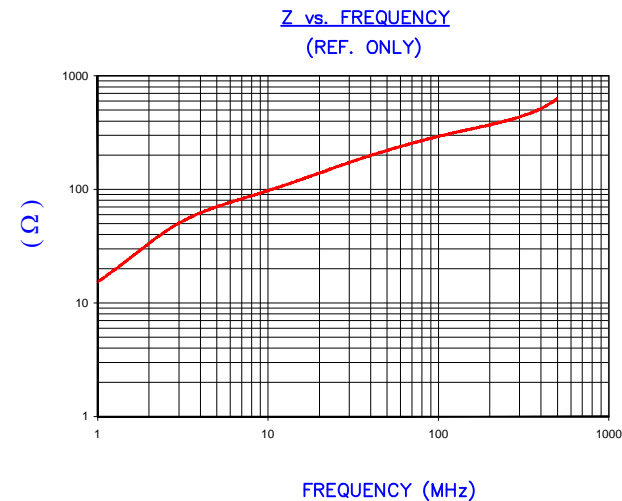

AGILENT E4991A Impedance/Material Analyzer
HP 16092A Test Fixture

FERRITE CORE DIMENSIONS (SPEC):

A	28.50 [1.122]	+	0.46 [.018]
B	13.77 [.542]	+	0.25 [.010]
C	28.58 [1.125]	+	0.76 [.030]

WEIGHT/1000 68.45 kgs [150.9 Lbs]

NOTES: UNLESS OTHERWISE SPECIFIED

1. COSMETIC SPECIFICATION REFER TO WI-QA-038.

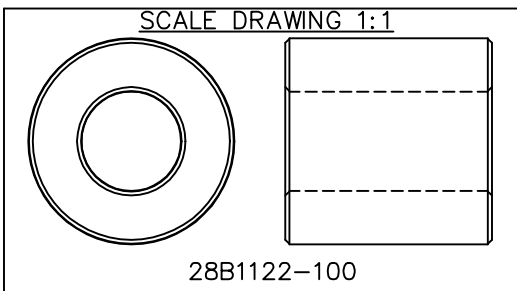

DIMENSIONS ARE IN mm [INCHES].				This print is the property of Laird Tech. and is loaned in confidence subject to return upon request and with the understanding that no copies shall be made without the written consent of Laird Tech. All rights to design or invention are reserved.			
REV	DESCRIPTION	DATE	INT				
G	UPDATE Z SPEC	10/25/13	Jcai	PROJECT/PART NUMBER: 28B1122-100		REV G	DRAWN BY: DJB
F	UPDATE COMPANY LOGO	12/28/12	QIU				
E	UPDATE PRINT & Z SPECS ADD CURVE REMOVE NOTE	07/18/03	JRK	DATE: 07/03/90		SCALE: 1.5 : 1	
D	CHG P/N TO -100 REM COATING SPECS UPDATE TO CNZ FORMAT UPDATE Z SPECS	07/31/02	JRK				
C	CHG P/N TO -10* ADD COATING SPECS	03/24/99	JRK	CAD # 28B1122-100-G		TOOL # B1122	
B	UPDATED P/N FOR NEW CATALOG	12/04/95	JBE				
A	ORIGINAL DRAFT	07/03/90	DJB	MATERIAL: FERRITE			
REV	DESCRIPTION	DATE	INT				