

May.1.2023 Copyright 2023 HIROSE ELECTRIC CO., LTD. All Rights Reserved.
In case of consideration for using Automotive equipment / device which demand high reliability, kindly contact our sales window correspondents.

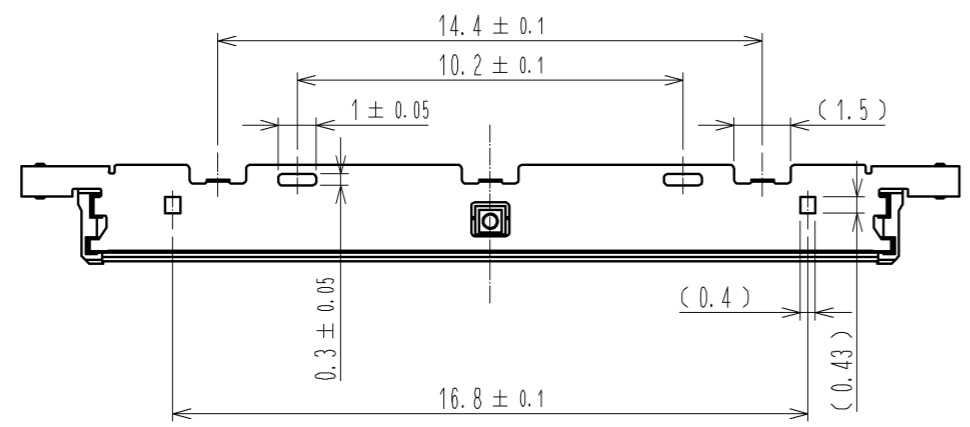

RECOMMENDED CABLE SUBASSEMBLY

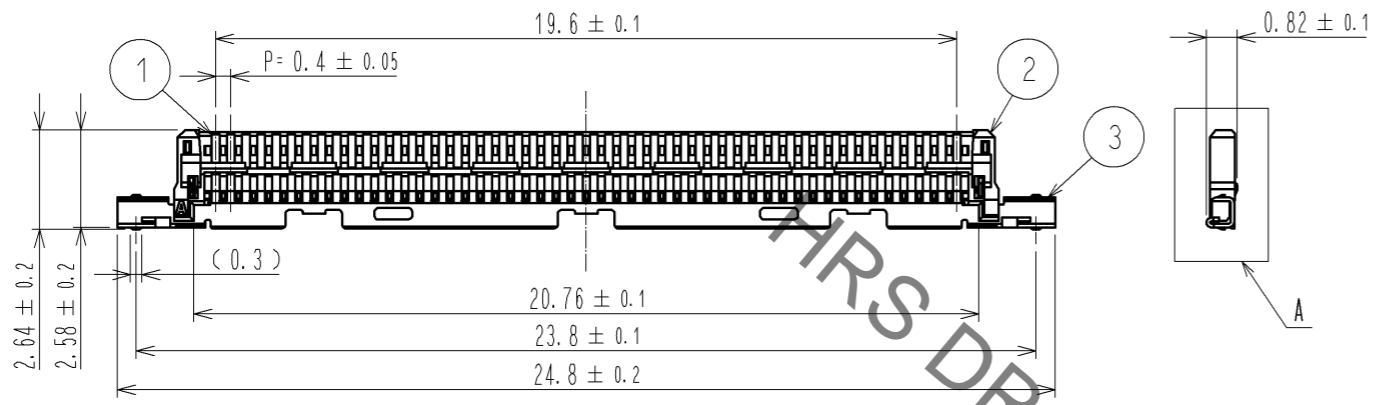
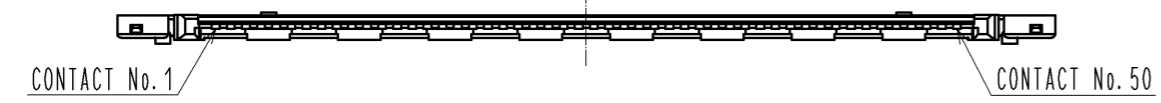
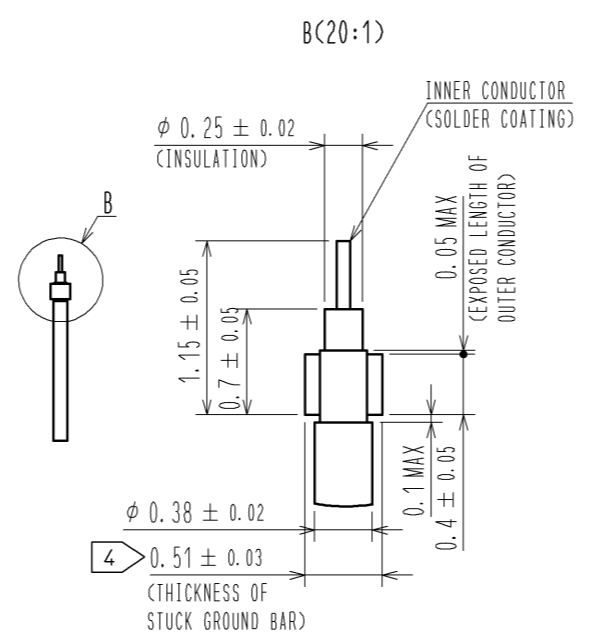
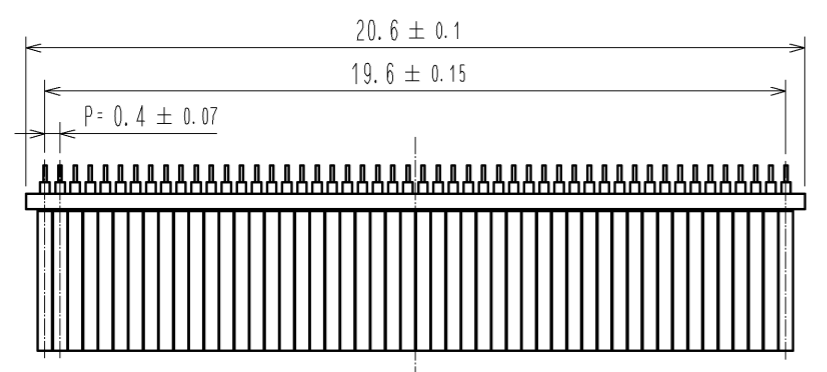

A (20:1) CABLE TERMINATION FIGURE (20:1)

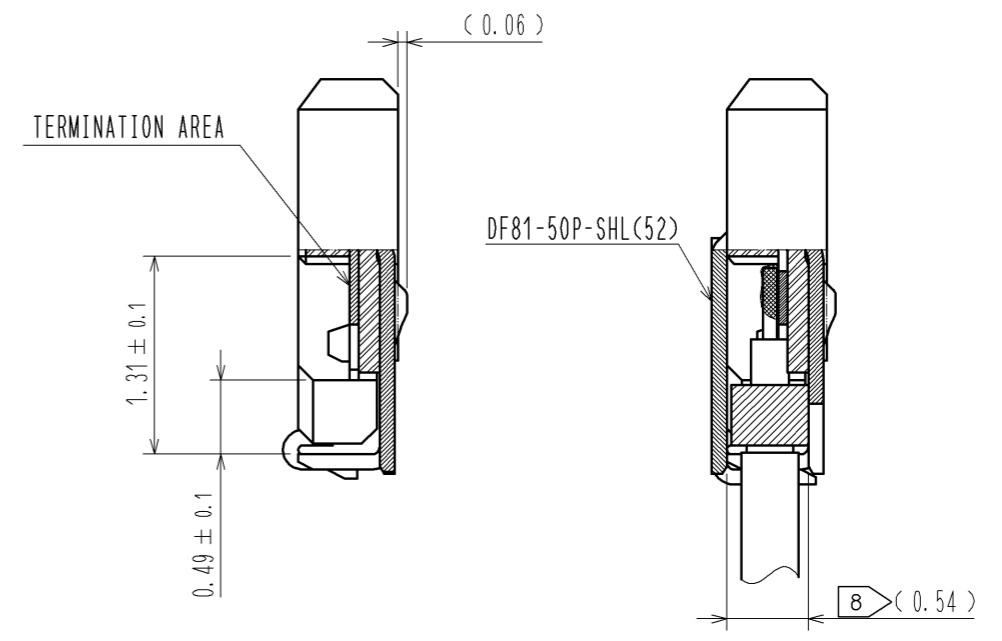

NOTES

1. APPLICABLE CABLE: MICRO COAXIAL CABLE(AWG#36~AWG#46)
2. THIS CONNECTOR IS NOT HOT PLUGGABLE. MATE AND UNMATE WHILE THE POWER IS OFF.
3. THE ASSEMBLY IS COMPLETED BY COMBINING THREE PARTS 'CONNECTOR UNIT, METAL SHIELDING' AND 'LATCH'. REFER TO THE TABLE FOR EACH ITEM No., PART NAME, PART No. AND CODE No.
4. SOLDER A GROUND BAR WITH AN EXTERNAL CONDUCTOR OF THE CABLE ABOUT STICKING A GROUND BAR TOGETHER.
5. PLEASE CONSULT ABOUT THE USE OF THE POTTING AND KAPTON TAPE SEPARATELY.
6. PLEASE ATTACH A LATCH BEFORE INCORPORATING SHELL. PLEASE REFER TO ASSEMBLY MANUAL FOR DETAILS.
7. THE DIMENSIONS IN PARENTHESES ARE FOR REFERENCE.
8. TOTAL THICKNESS OF ENCLOSED MATERIALS : 0.54mm MAX. THICKNESS EXCEEDING THE DIMENSION DOES NOT ALLOW THE METAL SHIELDING TO BE COMPLETELY FIT IN TO THE CONNECTOR.

ITEM No.	PART NAME	PART No.	CODE No.
1, 2, 3	CONNECTOR UNIT	DF81D-50P-0.4SD(52)	CL662-8122-7-52
-	METAL SHIELDING	DF81-50P-SHL(52)	CL662-8112-3-52
-	LATCH	DF81-50P-LCH(52)	CL662-8113-6-52

NO.	MATERIAL	FINISH	REMARKS	NO.	MATERIAL	FINISH	REMARKS
2	LCP		UL94V-0, BLACK	6	PS		BLACK
1	PHOSPHOR BRONZE		CONTACT AREA : Au PLATING 0.1μm min TERMINATION AREA : Au PLATING 0.1μm min UNDER PLATING : Ni PLATING 1 μm min	5	POLYESTER		CLEAR
				4	PS		CLEAR
				3	SUS		CONTACT AREA : Au PLATING 0.05μm min SOLDERING AREA : Au PLATING 0.05μm min UNDER PLATING : Ni PLATING 0.2 μm min

UNITS	SCALE	COUNT	DESCRIPTION OF REVISIONS	DESIGNED	CHECKED	DATE
mm	5 : 1	△				

HRS HIROSE ELECTRIC CO., LTD.	APPROVED : MH. YAMANE	13.11.26	DRAWING NO.	EDC3-351810-02
	CHECKED : MH. TSUCHIDA	13.11.25	PART NO.	DF81D-50P-0.4SD(52)
	DESIGNED : AH. MIYAZAKI	13.11.12	CODE NO.	CL662-8122-7-52
	DRAWN : AH. MIYAZAKI	13.11.12		

May.1.2023 Copyright 2023 HIROSE ELECTRIC CO., LTD. All Rights Reserved.
 In case of consideration for using Automotive equipment / device which demand high reliability, kindly contact our sales window correspondents.

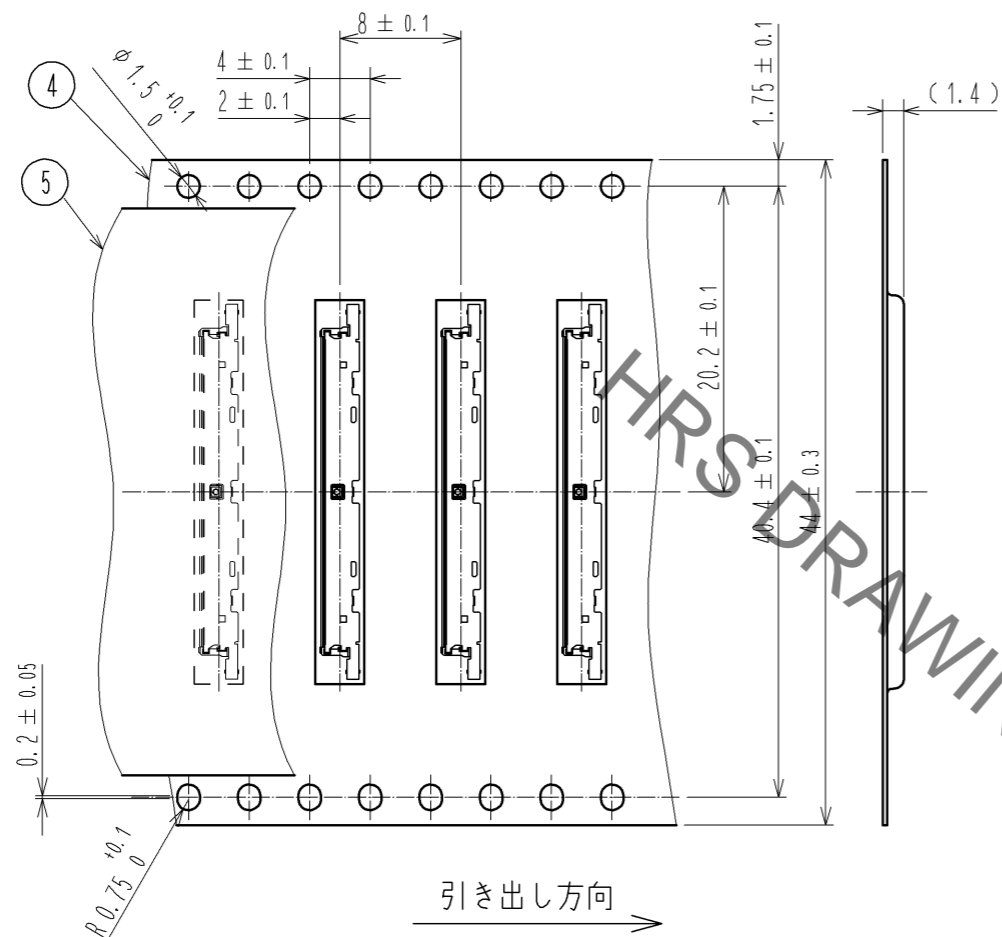

STYLE AND DIMENSION OF REEL (FREE)

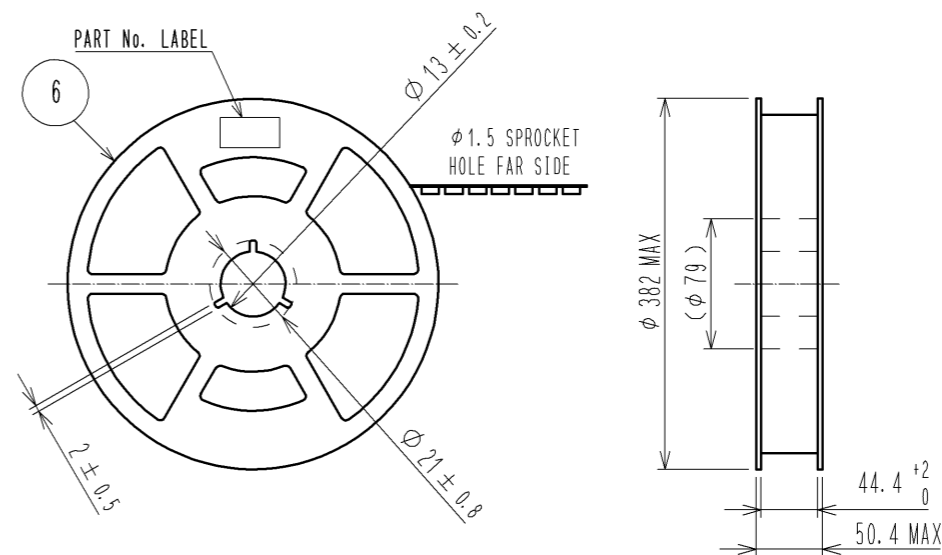

TAPING (FREE)

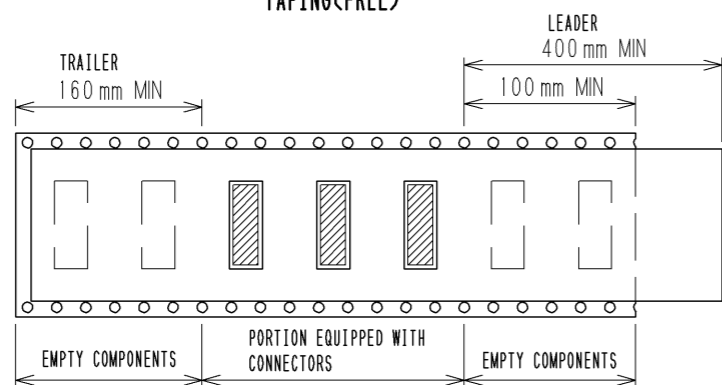

DETAIL OF PART No. LABEL (EXAMPLE)

生産月日	年月日
図番	CL662-8122-7-52
品名	DF81D-50P-0.4SD(52)
納入数量	500個
納入者	ヒロセ電機株式会社

- SUPPLIER
- QUANTITY
- PART No.
- CODE No.
- DATE OF MANUFACTURED

HRS

DRAWING NO.	EDC3-351810-02
PART NO.	DF81D-50P-0.4SD(52)
CODE NO.	CL662-8122-7-52

△ 2/2