

## CONREVSMA024-G

### Reverse-Polarity SMA Jack PCB Cutout Edge Mount Connector

---

Operating from 0 GHz to 18 GHz, the CONREVSMA024-G provides high performance and reliability in a small package. Mounting in a cutout/notch in a printed circuit board (PCB) the CONREVSMA024-G is more compact than standard board edge mount connectors. Additionally, all Linx connectors meet RoHS lead free standards and are tested to meet requirements for corrosion resistance, vibration, mechanical and thermal shock.

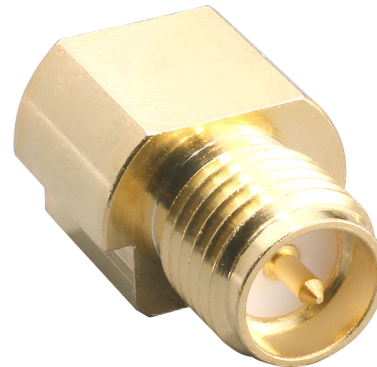

#### Features

- 0 to 18 GHz operation
- RP-SMA jack (male pin) connection
  - Gold plated brass connector body
  - Gold plated brass center contact
- Direct surface-mount PCB attachment
- Reflow- or hand-solder assembly

#### Electrical Specifications

<b>Impedance</b>	50 Ω
<b>Frequency Range</b>	0 to 18 GHz
<b>Insulation Resistance</b>	5000 MΩ min.
<b>Voltage Rating</b>	1000 V RMS
<b>Contact Resistance</b>	Center: ≤ 2.0 mΩ Outer: ≤ 2.0 mΩ
<b>Insertion Loss (dB max)</b>	-0.45 @ 6 GHz
<b>VSWR (max)</b>	1.15 @ 6 GHz

#### Ordering Information

Part Number	Description
CONREVSMA024-G	Reverse-polarity SMA jack (male pin), PCB cutout edge mount connector in trays (100 per tray)

Available from Linx Technologies and select distributors and representatives.

Product Dimensions

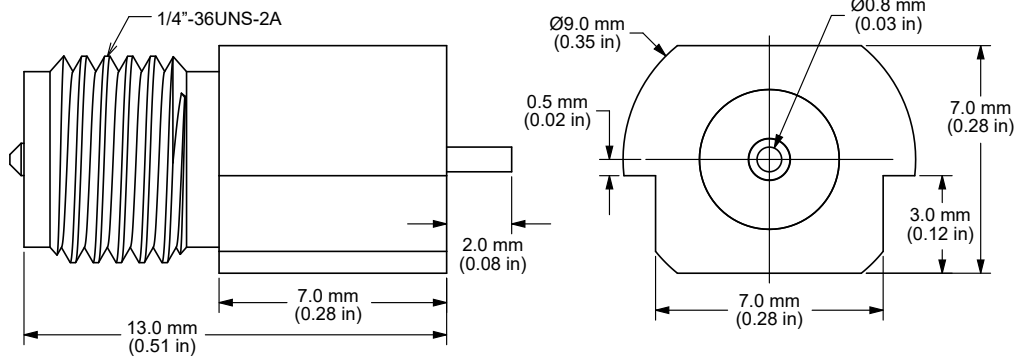

Figure 1. Product Dimensions for the CONREVSMA024-G Connector

Connector Components

CONREVSMA024-G		
Connector Part	Material	Finish
Connector Body	Brass	Gold
Center Contact	Brass	Gold
Insulator	PTFE	-

Recommended PCB Footprint

Figure 2 shows the recommended PCB footprint and PCB cutout dimensions.

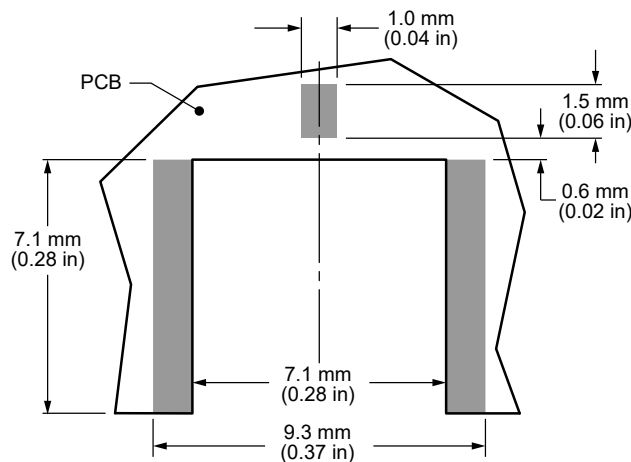

Figure 2. Recommended PCB Footprint for the CONREVSMA024-G Connector

Mechanical Specifications

CONREVSMA024-G	
Mounting Type	PCB board edge
Fastening Type	1/4\"/>

### Connector Performance

Table 1 shows insertion loss and VSWR values for the CONREVSMA024-G connector at commonly used frequencies.

Insertion loss is the loss of signal power (gain) resulting from the insertion of a device in a transmission line. VSWR describes how efficiently power is transmitted through the connector. A lower VSWR value indicates better performance at a given frequency.

**Table 1. Insertion Loss and VSWR for the CONREVSMA024-G Connector**

Band	Low-Band Cellular/ISM/LPWA	Midband Cellular/GNSS	WiFi/ISM	WiFi 6
Frequency Range	400 MHz to 960 MHz	1.1 GHz to 5 GHz	2.4 GHz	5 GHz to 7.125 GHz
Insertion Loss (dB max)	-0.08	-0.36	-0.18	-0.52
VSWR (max)	1.1	1.2	1.2	1.3

### Environmental Specifications

MIL-STD/Method/Test Condition	
Corrosion (Salt spray)	MIL-STD-202 Method 101 test condition B
Thermal Shock	MIL-STD-202 Method 107 test condition B
Vibration	MIL-STD-202 Method 204 test condition D
Mechanical Shock	MIL-STD-202 Method 213 test condition I
Temperature Range	-65 °C to +165 °C
Environmental Compliance	RoHS

### Reflow Solder Profile

Figure 3 shows the time and temperature data for reflow soldering the connector to a PCB.

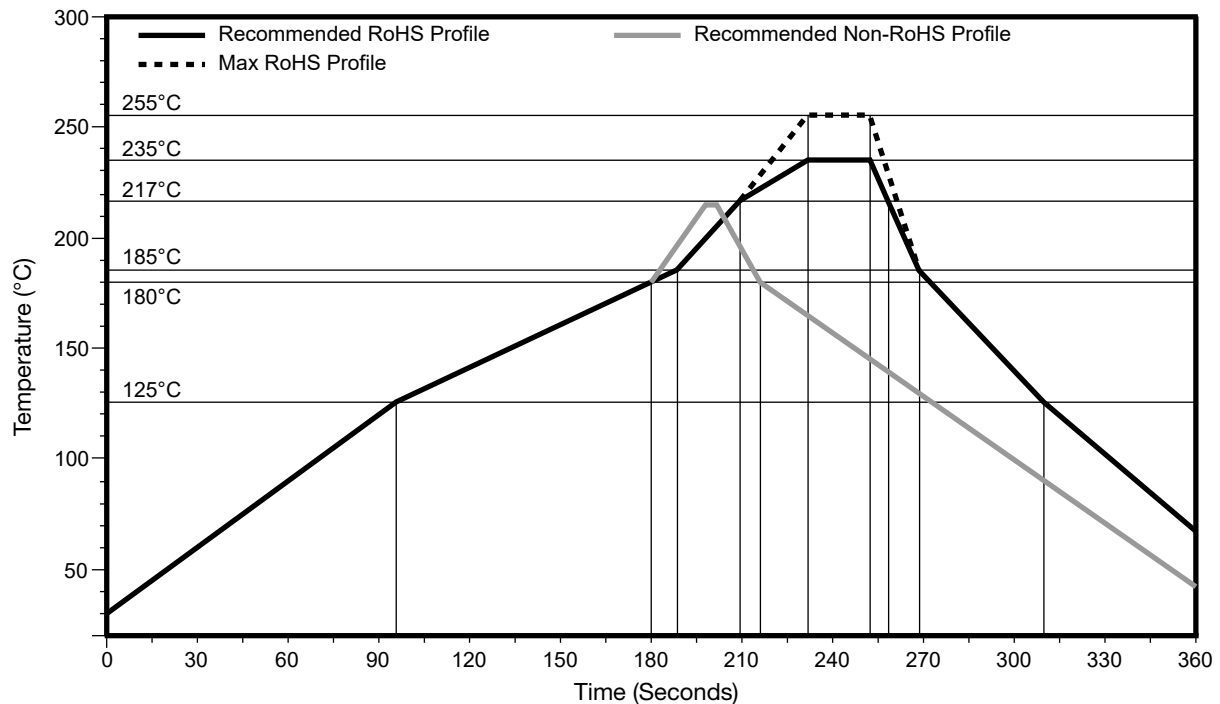

**Figure 3. Recommended Reflow Solder Profile**

---

**Website:** <http://linxtechnologies.com>  
**Linx Offices:** 159 Ort Lane, Merlin, OR, US 97532  
**Phone:** +1 (541) 471-6256  
**E-MAIL:** [info@linxtechnologies.com](mailto:info@linxtechnologies.com)

---

Linx Technologies reserves the right to make changes to the product(s) or information contained herein without notice. No liability is assumed as a result of their use or application. No rights under any patent accompany the sale of any such product(s) or information.

Wireless Made Simple is a registered trademark of Linx Acquisitions LLC. Other product and brand names may be trademarks or registered trademarks of their respective owners.

Copyright © 2020 Linx Technologies

All Rights Reserved

Doc# DS20268-105CON

