

May.1.2023 Copyright 2023 HIROSE ELECTRIC CO., LTD. All Rights Reserved.  
In case of consideration for using Automotive equipment / device which demand high reliability, kindly contact our sales window correspondents.

1 2 3 4 5 6 7 8

A  
B  
C  
D  
E  
F

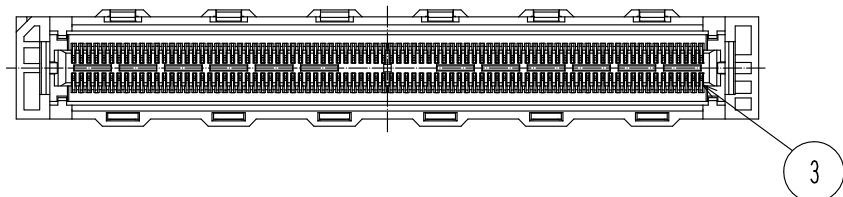
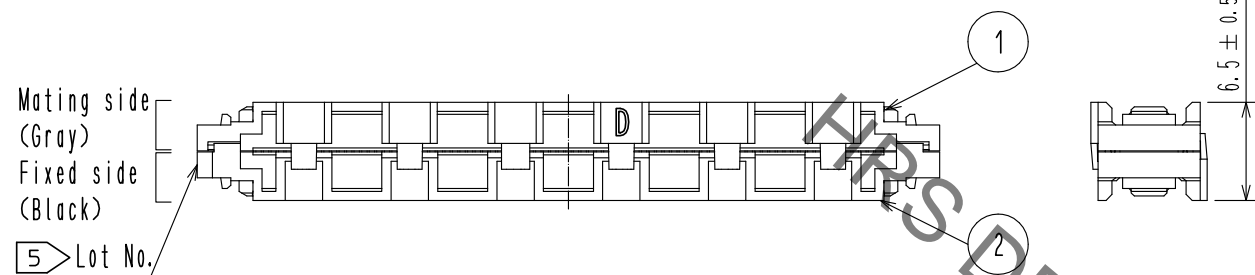
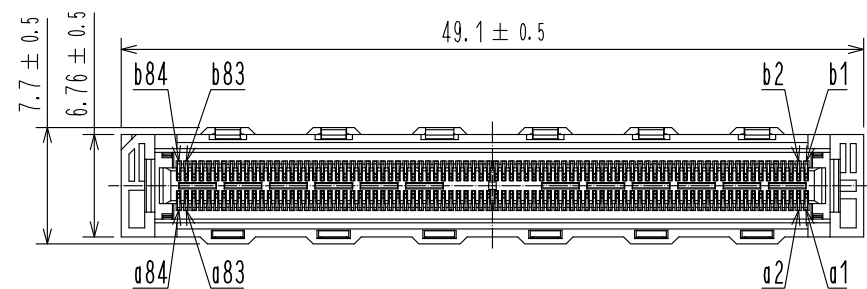

Table.1 Stacking height and connector combinations ◀ 1

Board distance (Stacking height)	Header connector of Board α	Interposer	Header connector of Board β	Recommended spacer height(L) ◀ 3
8mm	FX10A-168P-SV(**)	FX10-168IP-40D-8H(03)	FX10A-168P-SV(**)	8±0.127mm
9mm	FX10A-168P-SV1(**)		FX10A-168P-SV(**)	9±0.127mm
10mm	FX10A-168P-SV1(**)		FX10A-168P-SV1(**)	10±0.127mm

- Note.
- ◀ 1 The header connectors are decided by board distance (stacking height). Connector combination is shown in Table 1.
  - ◀ 2 Fixed side (Black side) of interposer should be mated with header mounted on board α. Mating side (Gray side) should be mated with header mounted on board β.
  - ◀ 3 Spacers are required to support the PWB's and protect the SMT solder joints. Recommended spacer height is shown in Table 1.
  - ◀ 4 Pin configuration is shown in Table 2. This product consists of 40 Differential pairs, 4 Single-ended lines and 84 ground lines.
  - ◀ 5 Lot No. shall be marked on the indicated position.
  - ◀ 6 50pcs of this product are packed in soft tray. See Fig.3 for details.

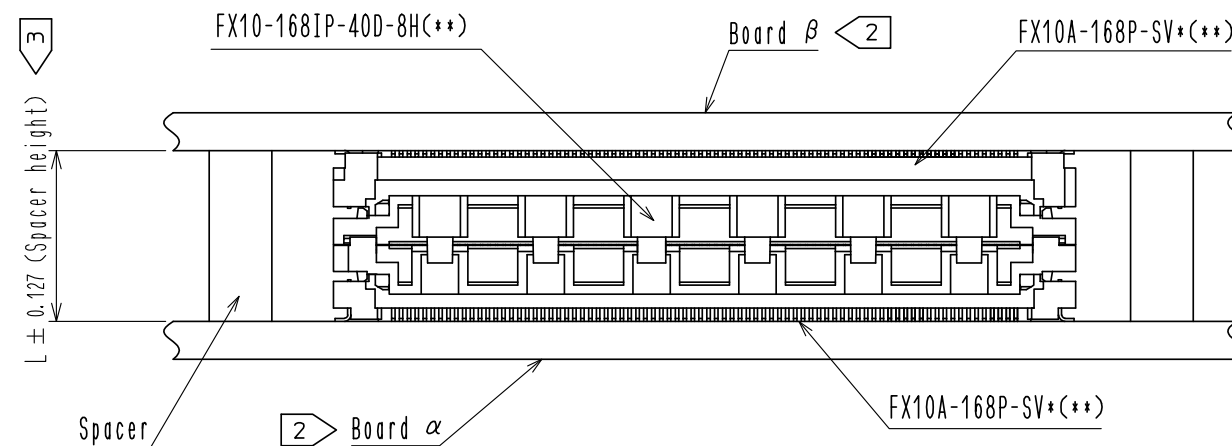

Fig.1 Recommended spacer height (Free)

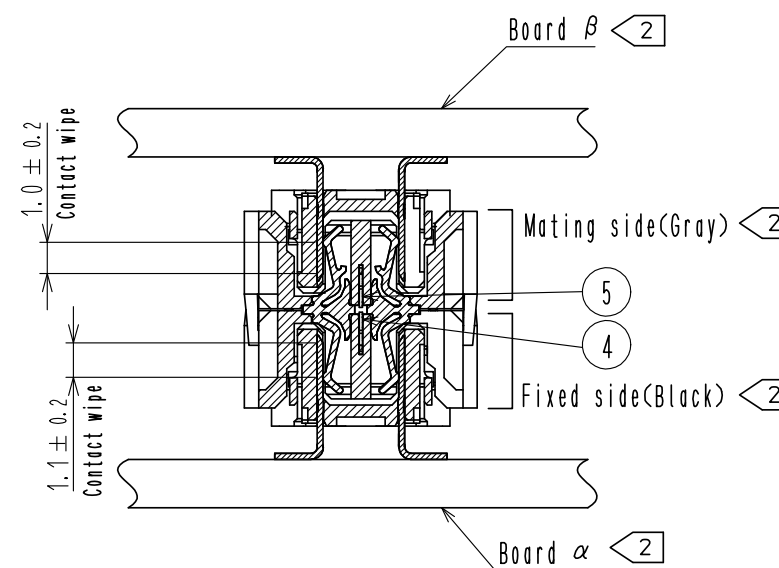

Fig.2 Mating cross section (Free)

3	Copper Alloy	Ni1.5μm+Au0.76μm	6	PS	(Tray)			
2	LCP(Black)	UL94V-0	5	Copper Alloy	Ni1μm			
1	LCP(Gray)	UL94V-0	4	Copper Alloy	Ni1μm			
NO.	MATERIAL	FINISH . REMARKS	NO.	MATERIAL	FINISH . REMARKS			
UNITS	mm	SCALE	2 : 1	COUNT	DESCRIPTION OF REVISIONS	DESIGNED	CHECKED	DATE
HRS HIROSE ELECTRIC CO., LTD.		APPROVED : TM. MATSUO	17.07.25	DRAWING NO. EDC-352036-03-00				
		CHECKED : TM. MATSUO	17.07.25	PART NO. FX10-168IP-40D-8H(03)				
		DESIGNED : AS. MATSUZAWA	17.07.25	CODE NO. CL608-0001-3-03				
		DRAWN : XINGYU CHENG	17.07.25					

FORM HC0011-5-7 1 2 3 4 5 6 7 8

May.1.2023 Copyright 2023 HIROSE ELECTRIC CO., LTD. All Rights Reserved.  
 In case of consideration for using Automotive equipment / device which demand high reliability, kindly contact our sales window correspondents.

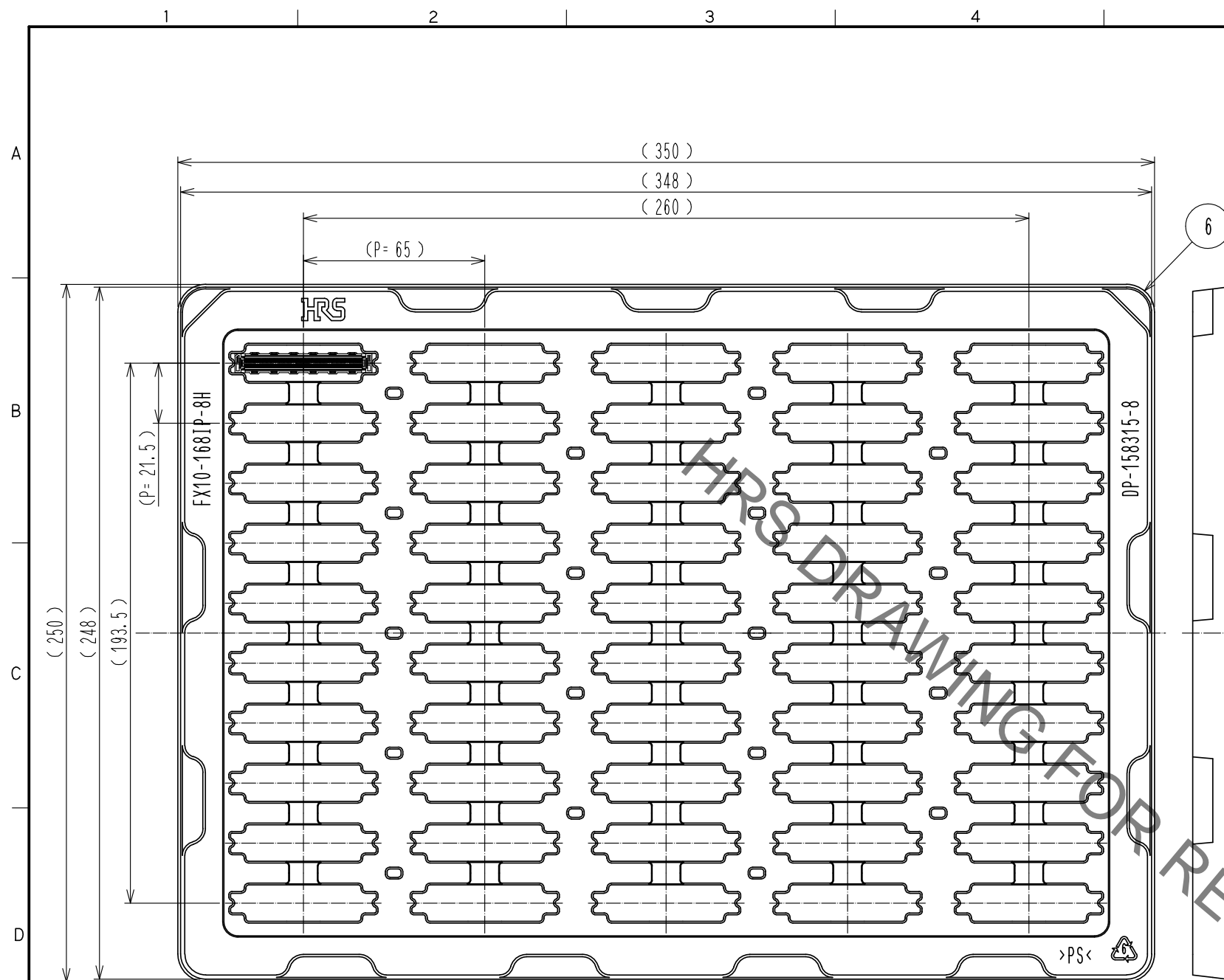

Fig.3 Drawing for packing (1:2) 6

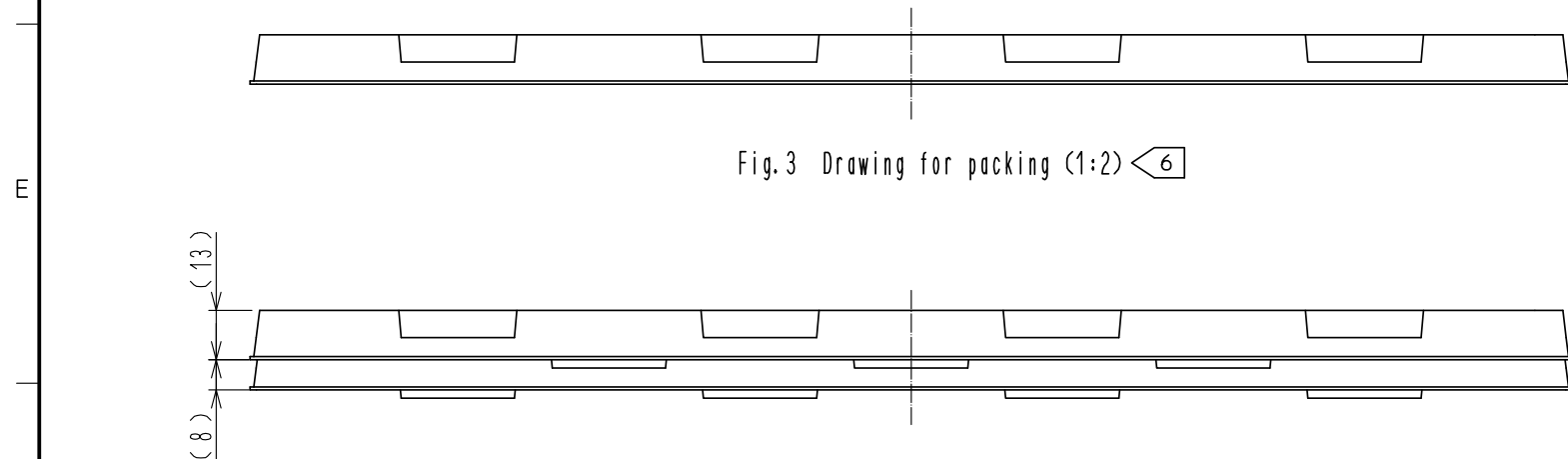

Fig.4 Stacked tray drawing (1:2)

Table.2 Pin configuration of Interposer 4

Row A Pin No.	a1	a2	a3	a4	a5	a6	a7	a8	a9	a10	a11	a12
Pin configuration	G1	S	G1	S	G1	S	G1	S	G1	S	G1	S
Row A Pin No.	a13	a14	a15	a16	a17	a18	a19	a20	a21	a22	a23	a24
Pin configuration	G1	S	G1	S	G1	S	G1	S	G1	S	G1	S
Row A Pin No.	a25	a26	a27	a28	a29	a30	a31	a32	a33	a34	a35	a36
Pin configuration	G1	S	G1	S	G1	S	G1	S	G1	S	G1	S
Row A Pin No.	a37	a38	a39	a40	a41	a42	a43	a44	a45	a46	a47	a48
Pin configuration	G1	S	G1	S	G1	SE	SE	G2	S	G2	S	G2
Row A Pin No.	a49	a50	a51	a52	a53	a54	a55	a56	a57	a58	a59	a60
Pin configuration	S	G2	S	G2	S	G2	S	G2	S	G2	S	G2
Row A Pin No.	a61	a62	a63	a64	a65	a66	a67	a68	a69	a70	a71	a72
Pin configuration	S	G2	S	G2	S	G2	S	G2	S	G2	S	G2
Row A Pin No.	a73	a74	a75	a76	a77	a78	a79	a80	a81	a82	a83	a84
Pin configuration	S	G2	S	G2	S	G2	S	G2	S	G2	S	G2
Row B Pin No.	b1	b2	b3	b4	b5	b6	b7	b8	b9	b10	b11	b12
Pin configuration	G1	S	G1	S	G1	S	G1	S	G1	S	G1	S
Row B Pin No.	b13	b14	b15	b16	b17	b18	b19	b20	b21	b22	b23	b24
Pin configuration	G1	S	G1	S	G1	S	G1	S	G1	S	G1	S
Row B Pin No.	b25	b26	b27	b28	b29	b30	b31	b32	b33	b34	b35	b36
Pin configuration	G1	S	G1	S	G1	S	G1	S	G1	S	G1	S
Row B Pin No.	b37	b38	b39	b40	b41	b42	b43	b44	b45	b46	b47	b48
Pin configuration	G1	S	G1	S	G1	SE	SE	G2	S	G2	S	G2
Row B Pin No.	b49	b50	b51	b52	b53	b54	b55	b56	b57	b58	b59	b60
Pin configuration	S	G2	S	G2	S	G2	S	G2	S	G2	S	G2
Row B Pin No.	b61	b62	b63	b64	b65	b66	b67	b68	b69	b70	b71	b72
Pin configuration	S	G2	S	G2	S	G2	S	G2	S	G2	S	G2
Row B Pin No.	b73	b74	b75	b76	b77	b78	b79	b80	b81	b82	b83	b84
Pin configuration	S	G2	S	G2	S	G2	S	G2	S	G2	S	G2

S: Signal for Differential SE: Signal for Single-ended G1: Common ground 1 G2: Common ground 2

<b>HRS</b>	DRAWING NO.	EDC-352036-03-00
	PART NO.	FX10-168IP-40D-8H(C03)
	CODE NO.	CL608-0001-3-03 <span style="border: 1px solid black; padding: 0 2px;">2</span> / <span style="border: 1px solid black; padding: 0 2px;">2</span>