

May.1.2023 Copyright 2023 HIROSE ELECTRIC CO., LTD. All Rights Reserved.
In case of consideration for using Automotive equipment / device which demand high reliability, kindly contact our sales window correspondents.

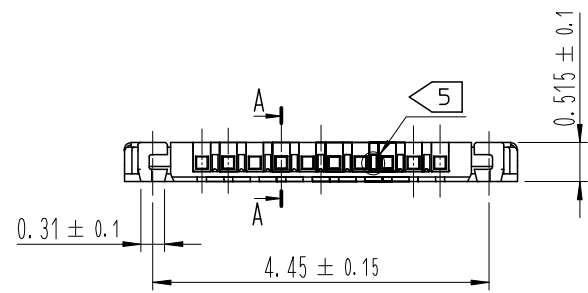
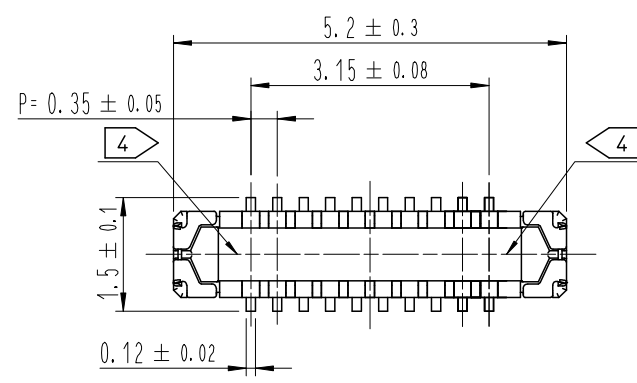

DRAWING FOR REFERENCE
This is subject to change without notice

- NOTE
- 1 . ALL LEAD CO-PLANARITY SHALL BE 0.08mm MAX.
 - 2 CONTACT PLATING SPECIFICATIONS.
CONTACT AREA : GOLD 0.05 μm MIN.
SMT LEAD : GOLD 0.05 μm MIN.
UNDER PLATING : NICKEL 1 μm MIN.
(SURFACE : SEALING)
 - 3 METAL FITTING PLATING SPECIFICATIONS.
SMT LEAD : GOLD 0.05 μm MIN.
UNDERPLATING : NICKEL 1 μm MIN.
(SURFACE : SEALING)
 - 4 HRS MARK AND CAV No. ARE INDICATED IN APPROX POSITION SHOWN.
 - 5 A PART OF THE WALL COULD BE NOTCHED.

COUNT	DESCRIPTION OF REVISIONS	B	Y	CHKD	DATE	COUNT	DESCRIPTION OF REVISIONS	B	Y	CHKD	DATE
△						△					
△						△					
△						△					

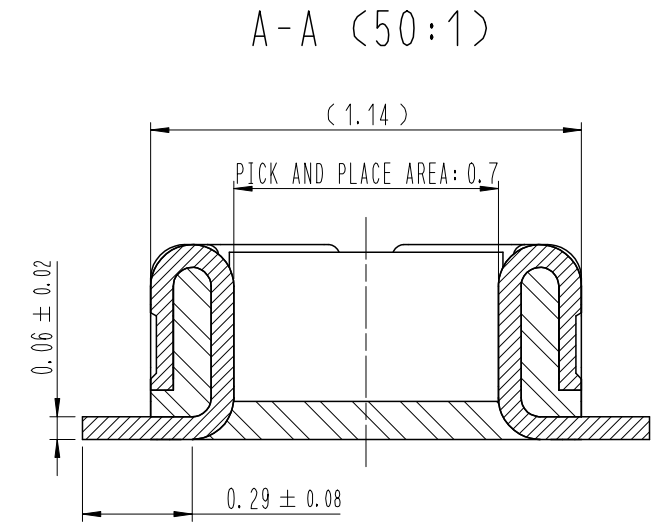

ENGAGEMENT FIGURE (50:1)

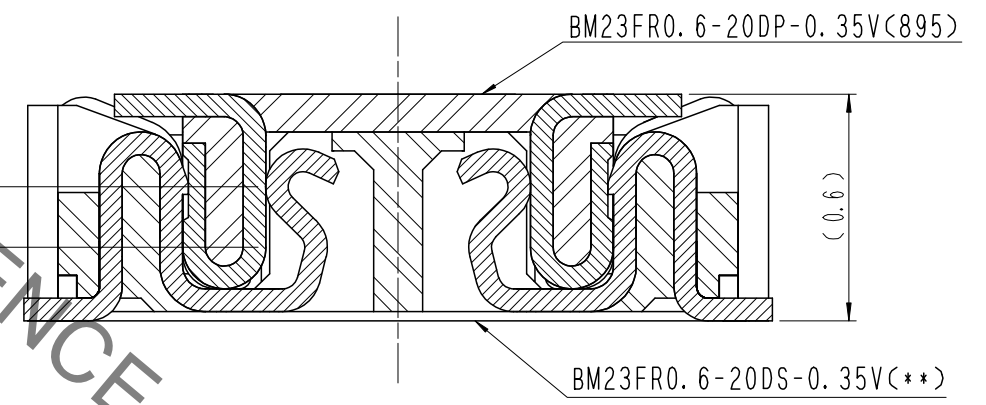

4	PS	CLEAR (EMBOSSD CARRIER TAPE)								
3	COPPER ALLOY	3	7	PS	CLEAR (REINFORCEMENT COLLAR)					
2	COPPER ALLOY	2	6	PS	BLACK (PLASTIC REEL)					
1	LCP	UL94 V-0, BLACK	5	POLYESTER	CLEAR (COVER TAPE)					
NO.	MATERIAL	FINISH, REMARKS	NO.	MATERIAL	FINISH, REMARKS					
REMARKS						DRAWN	DESIGNED	CHECKED	APPROVED	RELEASED
						S. H. JUNG	S. H. JUNG	H. W. JO	T. S. KANG	17.05.08
						17.05.08	17.05.08	17.05.08	17.05.08	17.05.08
CODE NO. (OLD)	DRAWING NO. EDC3-631850				PART NO. BM23FR0.6-20DP-0.35V(895)					
SCALE 10:1	HRS HIROSE KOREA CO., LTD.				CODE NO. CL 6644-0009-9-895					
UNITS mm										

HRS DRAWING FOR REFERENCE

May.1.2023 Copyright 2023 HIROSE ELECTRIC CO., LTD. All Rights Reserved.
In case of consideration for using Automotive equipment / device which demand high reliability, kindly contact our sales window correspondents.

7 RECOMMENDED PCB LAYOUT

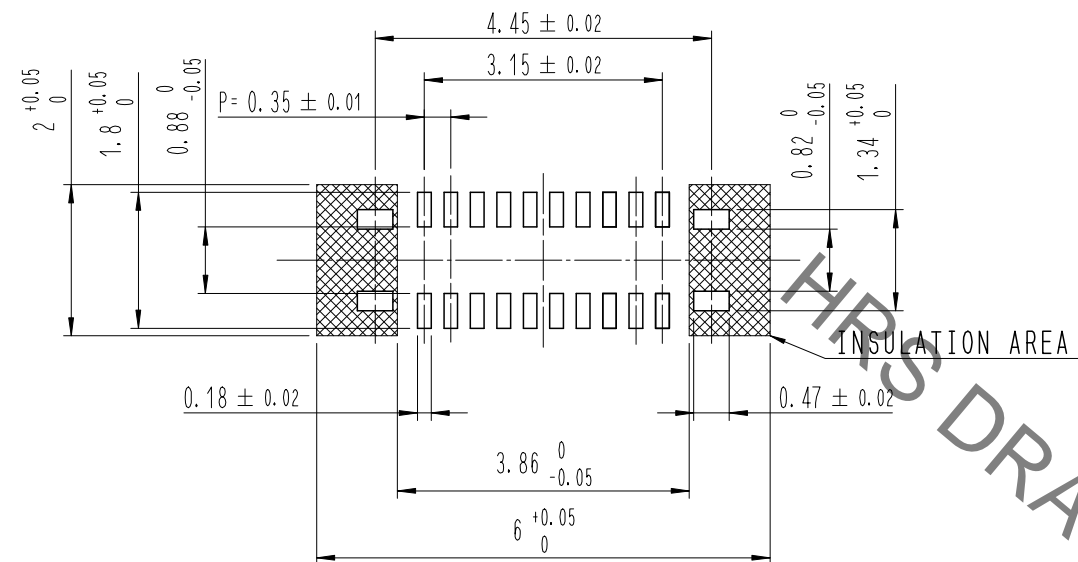

RECOMMENDED METAL MASK DIMENSIONS

METAL MASK THICKNESS : 100 μm

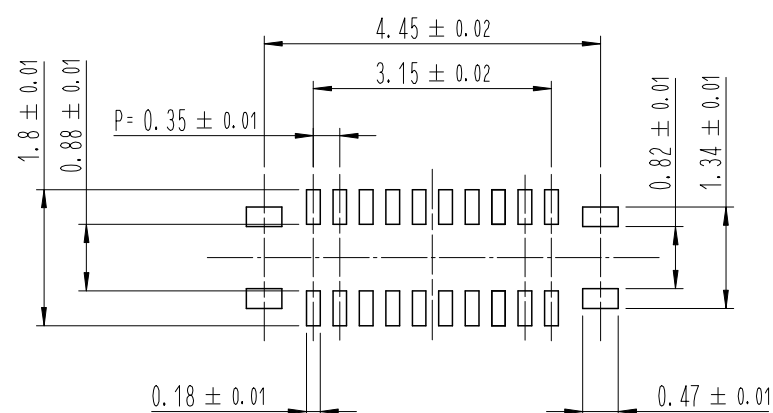

6 RECOMMENDED REFLOW TEMPERATURE PROFILE USING LEAD-FREE SOLDER PASTE.

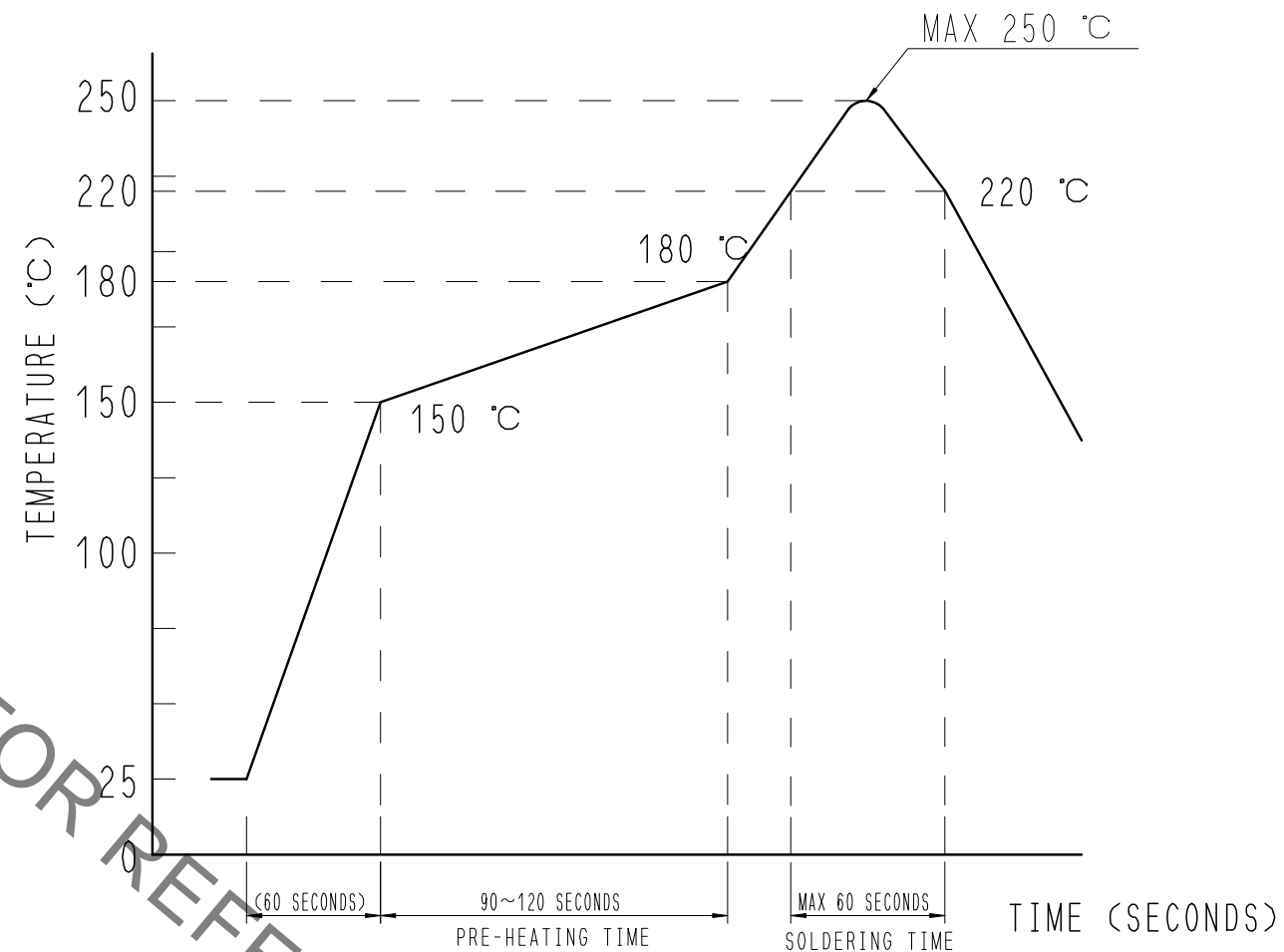

REFLOW METHOD: N2 REFLOW
NUMBER OF REFLOW CYCLES: 2 CYCLES MAX.

- 1) REFLOW TIME
DURATION ABOVE 220°C, 60 SEC MAX.
(PEAK TEMPERATURE: 250°C MAX)
- 2) PRE-HEAT TIME
PRE-HEAT TEMPERATURE(MIN): 150°C
PRE-HEAT TEMPERATURE(MAX): 180°C
PRE-HEAT TIME: 90-120 SEC.

- 6 THIS TEMPERATURE PROFILE IS PER THE CONDITIONS SHOWN ABOVE. ADDITIONAL FACTORS, SUCH AS SOLDER PASTE TYPE, PCB SIZE AND OTHER MOUNTED COMPONENTS COULD AFFECT THE PROFILE. THEREFORE, A THOROUGH EVALUATION OF MOUNTING CONDITION IS REQUIRED PRIOR TO PRODUCTION. TEMPERATURE IS MEASURED AT CONTACT LEAD.
- 7 PLEASE CONTACT US IN CASE YOU WILL MAKE DIFFERENT SETTINGS FROM OUR RECOMMENDATION.

	DRAWING NO.	EDC3-631850	PART NO.	BM23FR0.6-20DP-0.35V(895)	
	SCALE	10:1	CODE NO	CL 6644-0009-9-895	2/3
UNITS	mm		HRS HIROSE KOREA CO., LTD.		

May.1.2023 Copyright 2023 HIROSE ELECTRIC CO., LTD. All Rights Reserved.
In case of consideration for using Automotive equipment / device which demand high reliability, kindly contact our sales window correspondents.

EMBOSSED CARRIER TAPE PACKAGING (5:1)

STYLE AND DIMENTION OF REEL (FREE)

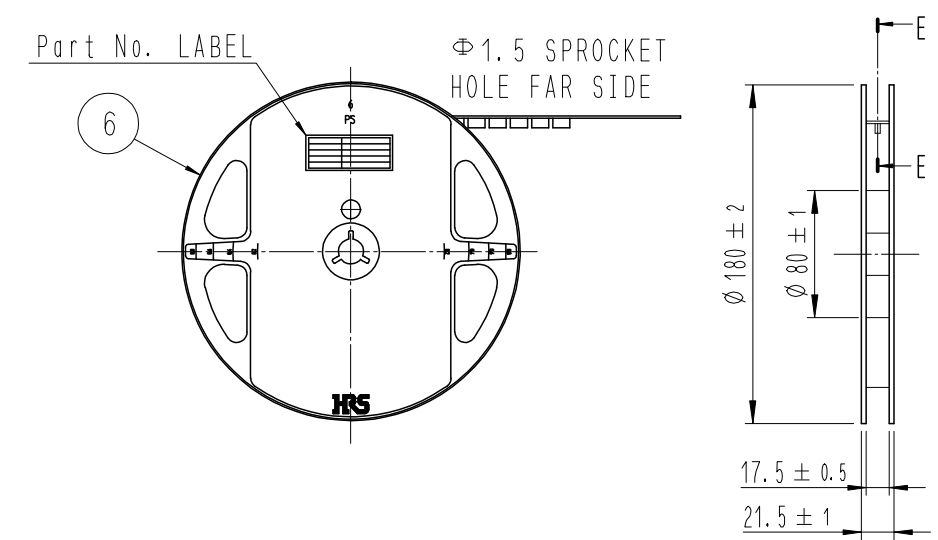
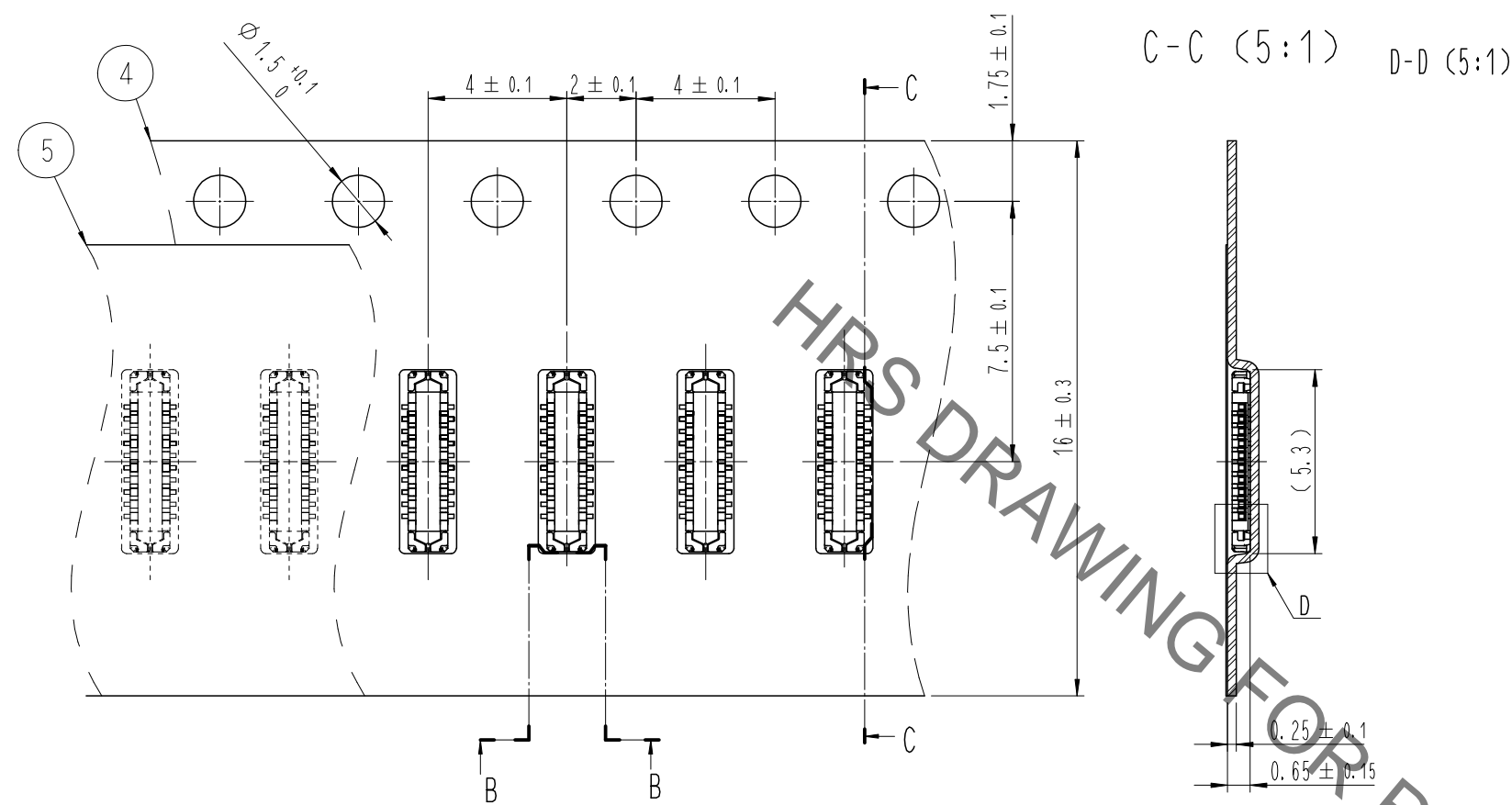

HRS DRAWING FOR REFERENCE

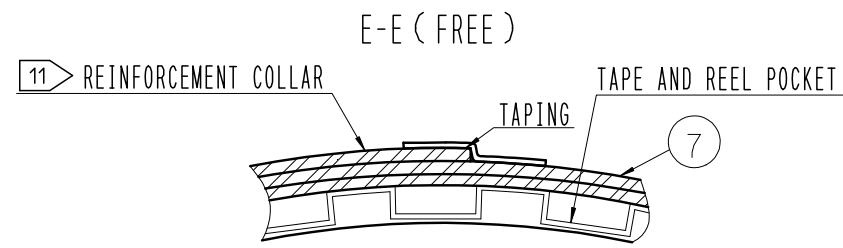

DETAIL OF PART No. LABEL

SUPPLIER	HIROSE ELECTRIC CO., LTD.
QUANTITY	1,000
PART NO.	BM23FR0.6-20DP-0.35V(895)
CODE NO.	CL 6644-0009-9-895
DATE OF MANUFACTURED	生産月日 年 月 日
箱番	** ** *
品名	BM23FR0.6-20DP-0.35V(895)
納入数量	1,000個
納入者	HIROSE KOREA

DIRECTION OF UNREELING

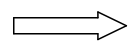

B-B (5:1)

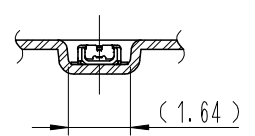

D (10:1)

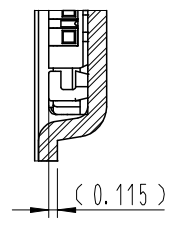

10 TAPING(FREE)

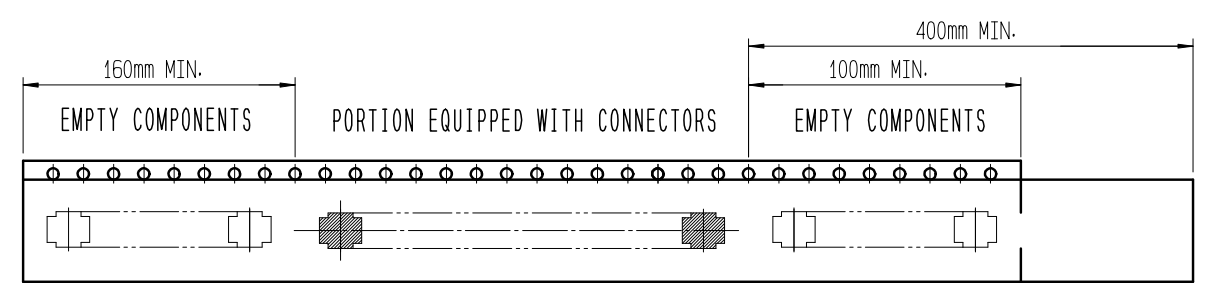

- 8 . PER REEL 1,000 CONNECTORS.
- 9 . THE DIMENSIONS IN PARENTHESES ARE FOR REFERENCE.
- 10 REFER TO JIS C 0806, IEC-60286-3 (PACKAGING OF COMPONENTS FOR AUTOMATIC HANDLING)
- 11 AFTER PACKAGING, ROLL 2 METERS OF THE REINFORCEMENT COLLAR TO OUTER CIRCUMFERENCE OF TAPE AND REEL POCKET, AND TAPE DOWN AT THE END THE COLLAR.

DRAWING NO. EDC3-631850	PART NO. BM23FR0.6-20DP-0.35V(895)	CODE NO. CL 6644-0009-9-895	3/3