

Low-Voltage Microcontroller with Infrared Module

General Description

The MAXQ305 is a reduced supply voltage, low-power, 16-bit MAXQ® microcontroller designed for low-power applications including universal remote controls, consumer electronics, and white goods. The MAXQ305 combines a powerful 16-bit RISC microcontroller and integrated peripherals including two USART ports and a SPI master/slave communications port, along with an IR module with carrier frequency generation and flexible port I/O capable of multiplexed keypad control. The MAXQ305 includes 80KB of flash program memory and 2KB of data SRAM.

The MAXQ305 can run from a low supply input voltage of 0.9V, allowing the microcontroller to be powered by a single alkaline AA battery. Code execution can run at up to a 12MHz rate, or the execution speed may optionally be decreased to 4MHz (Green Mode) to reduce power consumption. In this mode, the IR timer and modulator continue to run at 12MHz for maximum compatibility with existing IR application code.

For the ultimate in low-power battery-operated performance, the MAXQ305 includes an ultra-low-power stop mode (0.4µA, typ). In this mode, the minimum amount of circuitry is powered. Wake-up sources include external interrupts, the power-fail interrupt, and the wake-up timer interrupt.

Applications

Remote Controls
 Battery-Powered Portable Equipment
 Consumer Electronics
 Home Appliances
 White Goods

Ordering Information/Selector Guide appears at end of data sheet.

MAXQ is a registered trademark of Maxim Integrated Products, Inc.

Note: Some revisions of this device may incorporate deviations from published specifications known as errata. Multiple revisions of any device may be simultaneously available through various sales channels. For information about device errata, go to: www.maximintegrated.com/errata.
 For related parts and recommended products to use with this part, refer to: www.maximintegrated.com/MAXQ305.related

For pricing, delivery, and ordering information, please contact Maxim Direct at 1-888-629-4642, or visit Maxim Integrated's website at www.maximintegrated.com.

Features

- ◆ High-Performance, Low-Power 16-Bit RISC Core
- ◆ 0.9V to 3.6V Operating Voltage Range
- ◆ DC to 12MHz for Code Execution in Performance Mode
- ◆ 16-Bit Instruction Word, 16-Bit Data Bus
- ◆ 16 x 16-Bit General-Purpose Working Registers
- ◆ Secure MMU for Application Partitioning and IP Protection
- ◆ Memory Features
 - ◇ 80KB Program Flash Memory
 - ◇ 2KB Data SRAM
- ◆ Additional Peripherals
 - ◇ Power-Fail Warning
 - ◇ Power-On Reset/Brownout Reset
 - ◇ Automatic IR Carrier Frequency Generation and Modulation
 - ◇ One IR Diode Direct Drive Pin
 - ◇ Two High Current Visual LED Direct Drive Pins
 - ◇ Two 16-Bit, Programmable Timers/Counters
 - ◇ One SPI Port and Two USART Ports
 - ◇ Programmable Watchdog Timer
 - ◇ 8kHz Nanopower Ring Oscillator Wake-Up Timer
 - ◇ Up to 32 General-Purpose I/Os
- ◆ Low Power Consumption
 - ◇ 0.4µA (typ), 2.0µA (max) in Stop Mode, T_A = +25°C
 - ◇ 1.36mA (typ) in Green Mode (Code Execution at 4MHz)

Block Diagram

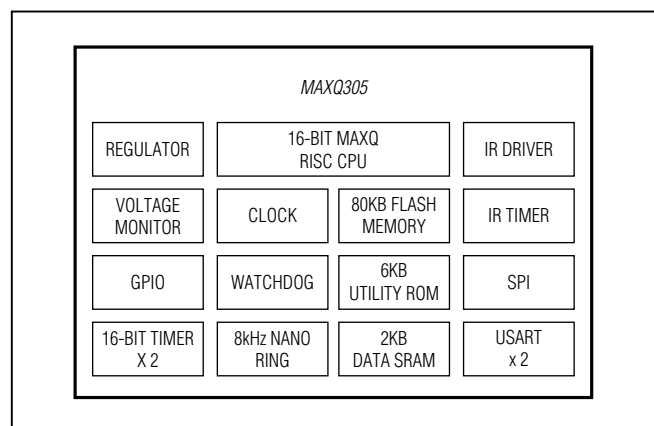

Low-Voltage Microcontroller with Infrared Module

ABSOLUTE MAXIMUM RATINGS

Voltage Range of V_{DD} with Respect to GND -0.3V to +3.6V
 Voltage Range on Any Lead
 with Respect to GND except V_{DD} -0.3V to ($V_{DD} + 0.5V$)
 Continuous Power Dissipation ($T_A = +70^\circ\text{C}$)
 TQFN (derate 37mW/ $^\circ\text{C}$ above +70 $^\circ\text{C}$).....2963mW

Operating Temperature Range -20 $^\circ\text{C}$ to +70 $^\circ\text{C}$
 Storage Temperature Range..... -65 $^\circ\text{C}$ to +150 $^\circ\text{C}$
 Lead Temperature (soldering, 10s)+300 $^\circ\text{C}$
 Soldering Temperature (TQFN only, reflow)+260 $^\circ\text{C}$

Stresses beyond those listed under "Absolute Maximum Ratings" may cause permanent damage to the device. These are stress ratings only, and functional operation of the device at these or any other conditions beyond those indicated in the operational sections of the specifications is not implied. Exposure to absolute maximum rating conditions for extended periods may affect device reliability.

PACKAGE THERMAL CHARACTERISTICS (Note 1)

TQFN

Junction-to-Ambient Thermal Resistance (θ_{JA}).....27 $^\circ\text{C}/\text{W}$
 Junction-to-Case Thermal Resistance (θ_{JC}).....1 $^\circ\text{C}/\text{W}$

Note 1: Package thermal resistances were obtained using the method described in JEDEC specification JESD51-7, using a four-layer board. For detailed information on package thermal considerations, refer to www.maxim-ic.com/thermal-tutorial.

RECOMMENDED OPERATING CONDITIONS

($V_{DD} = V_{DD(MIN)}$ to $V_{DD(MAX)}$, $T_A = -20^\circ\text{C}$ to +70 $^\circ\text{C}$, typical $T_A = +25^\circ\text{C}$, $V_{DD(TYP)}$, unless otherwise noted. Specifications to $T_A = -20^\circ\text{C}$ are guaranteed by design and are not production tested.)

PARAMETER	SYMBOL	CONDITIONS	MIN	TYP	MAX	UNITS
Supply Voltage	V_{DD}		V_{RST}	1.5	3.6	V
Supply Voltage (High Voltage Mode)	V_{DD_HV}	HVREN = HVRMD = 1	1.2			V
Supply Voltage (Performance Mode)	V_{DD_PFM}	HVREN = HVRMD = PFMSEL = 1, $f_{SYSCLK} = f_{HFXIN} = 12\text{MHz}$	1.2			V
Regulator Output	V_{REGOUT_1}	HVRMD = 0	1.26	1.4	1.54	V
	V_{REGOUT_2}	HVRMD = 1		1.8		
Power-Fail Warning Voltage for Supply (Note 2)	V_{PFW}	Monitors V_{DD}	0.95	1.0	1.05	V
Power-Fail Reset Voltage	V_{RST}	Monitors V_{DD}	0.9	0.925	0.95	V
Power-On Reset Voltage	V_{POR}	Monitors V_{DD}		0.8		V
RAM Data-Retention Voltage	V_{DRV}	(Note 3)	0.7			V
Active Current	I_{DD_1}	Source clock = 12MHz, Sysclk = 4MHz (green mode), HVREN = HVRMD = PFMSEL = 0 (Note 4)		1.36		mA
Active Current	I_{DD_2}	Source clock = 12MHz, Sysclk = 4MHz (green mode), HVREN = HVRMD = PFMSEL = 0 (Note 4)		10		mA
Active Current During Flash Programming	I_{DD_FP}	$V_{DD} = V_{RST}$ to 1.0V, $f_{SYSCLK} = 4\text{MHz}$, HVREN = HVRMD = PFMSEL = 0		10		mA

Low-Voltage Microcontroller with Infrared Module

RECOMMENDED OPERATING CONDITIONS (continued)

($V_{DD} = V_{DD(MIN)}$ to $V_{DD(MAX)}$, $T_A = -20^{\circ}\text{C}$ to $+70^{\circ}\text{C}$, typical $T_A = +25^{\circ}\text{C}$, $V_{DD(TYP)}$, unless otherwise noted. Specifications to $T_A = -20^{\circ}\text{C}$ are guaranteed by design and are not production tested.)

PARAMETER	SYMBOL	CONDITIONS	MIN	TYP	MAX	UNITS
Stop Mode Current	I_{STOP1}	Power-fail off, $T_A = +25^{\circ}\text{C}$		0.4	3.5	μA
		Power-fail off, $T_A = 0$ to $+70^{\circ}\text{C}$		0.4	12	
	I_{STOP2}	Power-fail on, $T_A = +25^{\circ}\text{C}$		22		
		Power-fail on, $T_A = 0$ to $+70^{\circ}\text{C}$		22		
Current Consumption During Power-Fail	I_{PFR}	(Note 5)	$((3 \times I_{STOP2}) + ((PCI - 3) \times (I_{STOP1} + I_{NANO}))) / PCI$			μA
Power Consumption During Power-On Reset	I_{POR}	(Note 6)		100		nA
Stop-Mode Resume Time (Note 7)	t_{ON}	$V_{DD} \geq 1.5\text{V}$		375		μs
		$V_{DD} < 1.5\text{V}$		550		
Power-Fail Monitor Startup Time	t_{PFM_ON}			150		μs
Power-Fail Warning Detection Time	t_{PFW}	(Note 8)		10		μs
Input Low Voltage for IRTX, IRRX, HFXIN, $\overline{\text{RESET}}$, and All Port Pins	V_{IL}		V_{GND}		$0.3 \times V_{DD}$	V
Input High Voltage for IRTX, IRRX, HFXIN, $\overline{\text{RESET}}$, and All Port Pins	V_{IH}		$0.7 \times V_{DD}$		V_{DD}	V
Input Hysteresis (Schmitt)	V_{IHYS}	$V_{DD} \geq 1.5\text{V}$		300		mV
		$V_{DD} < 1.5\text{V}$		50		
IRRX Input Filter Pulse-Width Reject	t_{IRRX_R}				50	ns
IRRX Input Filter Pulse-Width Accept	t_{IRRX_A}		300			ns
Output Low Voltage for $\overline{\text{RESET}}$ and All Port Pins (Note 9)	V_{OL}	$V_{DD} = 3.6\text{V}$, $I_{OL} = 11\text{mA}$		0.4	0.5	V
		$V_{DD} = 2.35\text{V}$, $I_{OL} = 8\text{mA}$		0.4	0.5	V
		$V_{DD} = 1.85\text{V}$, $I_{OL} = 4.5\text{mA}$		0.4	0.5	V
		$V_{DD} = 0.9\text{V}$, $I_{OL} = 20\mu\text{A}$		0.1	0.15	V
Output High Voltage for $\overline{\text{RESET}}$ and All Port Pins (Note 9)	V_{OH}	$V_{DD} = 1.62\text{V}$ to 3.6V , $I_{OH} = 2\text{mA}$		$V_{DD} - 0.5$	V_{DD}	V
		$V_{DD} = 0.9\text{V}$, $I_{OH} = 20\mu\text{A}$		$V_{DD} - 0.15$	V_{DD}	
IRTX Reference Current	I_{IRTX}	Constant used to calculate IRTX drive		100		mA
LED Reference Current	I_{LED}	Constant used to calculate LED[1:0] drive		5		mA

MAXQ305

Low-Voltage Microcontroller with Infrared Module

RECOMMENDED OPERATING CONDITIONS (continued)

($V_{DD} = V_{DD(MIN)}$ to $V_{DD(MAX)}$, $T_A = -20^{\circ}\text{C}$ to $+70^{\circ}\text{C}$, typical $T_A = +25^{\circ}\text{C}$, $V_{DD(TYP)}$, unless otherwise noted. Specifications to $T_A = -20^{\circ}\text{C}$ are guaranteed by design and are not production tested.)

PARAMETER	SYMBOL	CONDITIONS	MIN	TYP	MAX	UNITS
Input/Output Pin Capacitance for All Port Pins	C_{IO}	(Note 3)		15		pF
Input Leakage Current	I_L	Internal pullup disabled	-100		+100	nA
Input Pullup Resistor for $\overline{\text{RESET}}$, IRRX, All Port Pins Except P1.6, P1.7 (Note 3)	R_{PU}	$V_{DD} = 3.0\text{V}$, $V_{OL} = 0.4\text{V}$		28		k Ω
		$V_{DD} = 2.0\text{V}$, $V_{OL} = 0.4\text{V}$		30		k Ω
		$V_{DD} = 0.9\text{V}$, $V_{OL} = 0.1\text{V}$		50		k Ω
EXTERNAL CRYSTAL/RESONATOR						
Crystal/Resonator Frequency	f_{HFxin}				12	MHz
Crystal/Resonator Period	t_{HFxin}			$1/f_{\text{HFxin}}$		ns
Crystal/Resonator Warm-Up Time	$t_{\text{XTAL_RDY}}$	From initial oscillation		$8192 \times t_{\text{HFxin}}$		ms
Oscillator Feedback Resistor	R_{OSCF}		0.5	1.0	1.5	M Ω
EXTERNAL CLOCK INPUT						
External Clock Frequency	f_{XCLK}		DC		12	MHz
External Clock Period	t_{XCLK}			$1/f_{\text{XCLK}}$		ns
External Clock Duty Cycle	$t_{\text{XCLK_DUTY}}$		45		55	%
System Clock Frequency (Green Mode)	f_{CK}			$f_{\text{HFxin}}/3$		MHz
		HFXOUT = GND		$f_{\text{XCLK}}/3$		
System Clock Period	t_{CK}			$1/f_{\text{CK}}$		ns
1MHZ RING						
Nano-Ring Frequency	f_{INTOSC}			1		MHz
NANO RING						
Nano-Ring Frequency	f_{NANO}	$T_A = +25^{\circ}\text{C}$	3.0	8.0	20.0	kHz
Nano-Ring Current	I_{NANO}	$V_{DD} = 0.85\text{V}$ to 1.70V		250		nA
WAKE-UP TIMER						
Wake-Up Timer Interval	t_{WAKEUP}		$1/f_{\text{NANO}}$		$65535/f_{\text{NANO}}$	s
RECOMMENDED FLASH MEMORY PARAMETERS						
System Clock During Flash Programming/Erase	f_{FPSYSCLK}	RGSL = 0		2		MHz
Flash Programming Voltage	V_{FPROG}	(Note 10)	1.2			V
Flash Erase Time (Note 11)	t_{ME}	Mass erase	20		40	ms
	t_{ERASE}	Page erase	20		40	
Flash Programming Time Per Word	t_{PROG}	(Notes 3, 11)	20		100	μs
Write/Erase Cycles			20,000			Cycles
Data Retention		$T_A = +25^{\circ}\text{C}$	100			Years

Low-Voltage Microcontroller with Infrared Module

RECOMMENDED OPERATING CONDITIONS (continued)

($V_{DD} = V_{DD(MIN)}$ to $V_{DD(MAX)}$, $T_A = -20^{\circ}\text{C}$ to $+70^{\circ}\text{C}$, typical $T_A = +25^{\circ}\text{C}$, $V_{DD(TYP)}$, unless otherwise noted. Specifications to $T_A = -20^{\circ}\text{C}$ are guaranteed by design and are not production tested.)

PARAMETER	SYMBOL	CONDITIONS	MIN	TYP	MAX	UNITS
IR						
Carrier Frequency	f_{IRX}	External crystal			$f_{HFXIN}/2$	Hz
	f_{IRC}	External clock			$f_{XCLK}/2$	
IR Transmission Rate	f_{IR_RATE}	IRIOCN.IRRATE = 0		1		MHz

- Note 2:** The VPFW level can be programmed to one of a range of trip points as defined by PWCN.PFWARNCN[1:0]. The values listed in the [Recommended Operating Conditions](#) table are for the default configuration of 1.0V (nominal) $\pm 5\%$.
- Note 3:** Guaranteed by design, not production tested.
- Note 4:** Measured on the V_{DD} pin with the device not in reset. All inputs are tied to GND or V_{DD} . Outputs do not source/sink any current. Part is executing code from flash memory.
- Note 5:** The power check interval (PCI) can be set to check once every 1024, 2048, or 4096 nano-ring clock cycles. If the PCI is set to check every clock cycle, then this value will be equal to I_{STOP} . The power check interval (PCI) can be set to always on, 1024, 2048, or 4096 nano-ring clock cycles.
- Note 6:** Current consumption during POR when powering up while V_{DD} is less than the POR release voltage.
- Note 7:** After typical startup time, and before the completion of an 8192 t_{HFXIN} crystal warmup period, the microcontroller runs off of a 1MHz ring oscillator.
- Note 8:** The minimum amount of time that V_{DD} must be below V_{PFW} before a power-fail event is detected; refer to the user's guide for detailed information.
- Note 9:** The maximum total current, $I_{OH(MAX)}$ and $I_{OL(MAX)}$, for all listed outputs combined, should not exceed 32mA to satisfy the maximum specified voltage drop. This does not include the IRTX or LED outputs.
- Note 10:** Do not write to flash memory while $V_{DD} < V_{DD_HV(MIN)}$. The flash memory write functions in the utility ROM attempt to enable the high voltage mode if not already enabled, and return an error code if $V_{DD} < V_{DD_HV(MIN)}$.
- Note 11:** Programming time does not include overhead associated with utility ROM interface.

MAXQ305

Low-Voltage Microcontroller with Infrared Module

Pin Configuration

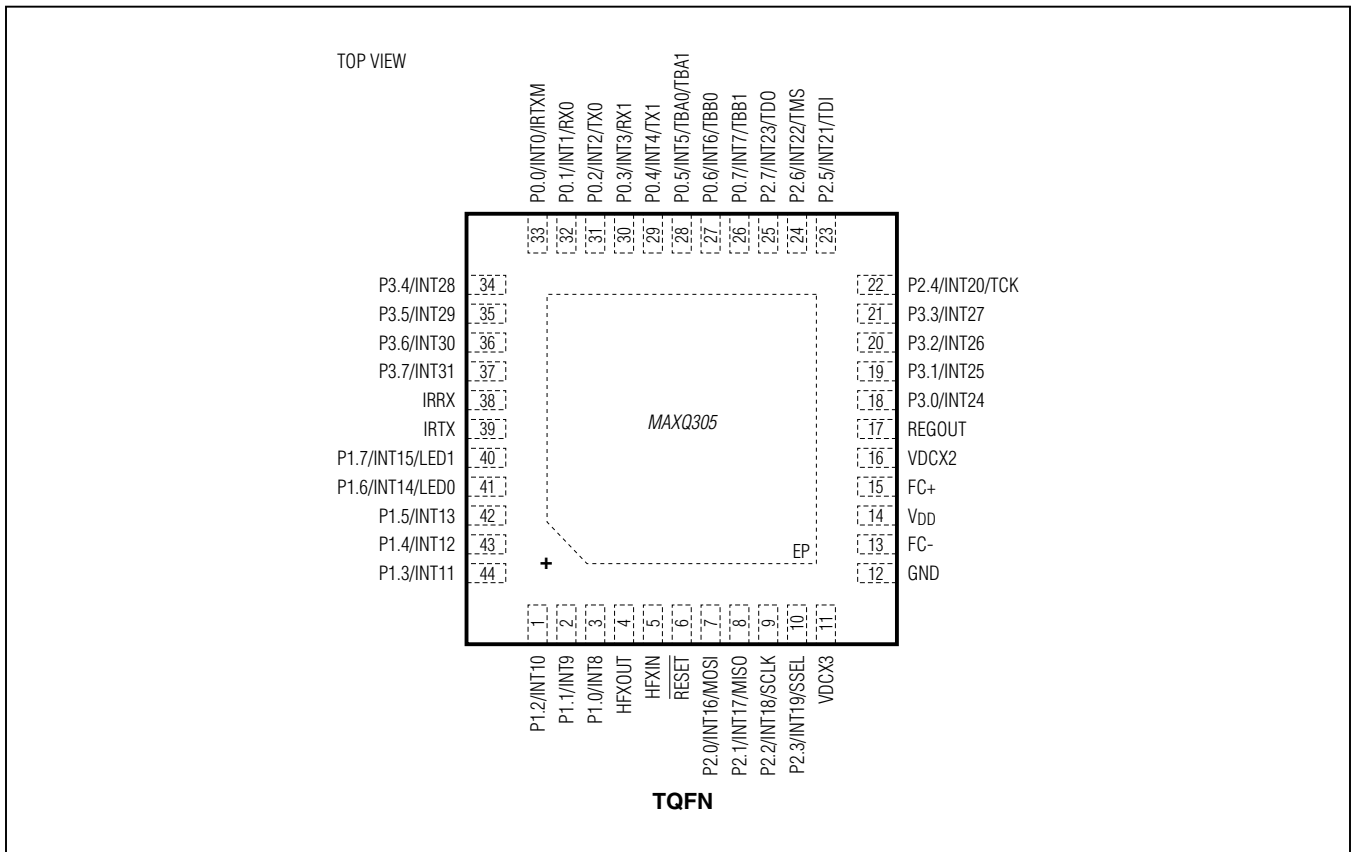

Pin Description

PIN		NAME	FUNCTION
BARE DIE	TQFN		
POWER PINS			
16	14	V _{DD}	Supply Voltage.
14	12	GND	Ground. Connect directly to the ground plane.
5, 31	EP	GND	Ground–Exposed Pad. The exposed pad is found only on the TQFN packages. It should be connected directly to the ground plane.
19	17	REGOUT	Internal Regulator Output. This pin must be connected to ground through a 1.0μF external ceramic chip capacitor. The capacitor must be placed as close to this pin as possible. No devices other than the capacitor should be connected to this pin.
17	15	FC+	2x Charge-Pump Capacitor Pins. Connect a 270nF external capacitor between FC+ and FC-.
15	13	FC-	

MAXQ305

Low-Voltage Microcontroller with Infrared Module

Pin Description (continued)

PIN		NAME	FUNCTION
BARE DIE	TQFN		
18	16	VDCX2	2x Charge-Pump Output. Connect a 4.7 μ F external capacitor between this pin and ground. No devices other than the capacitor should be connected to this pin, except for functional circuitry related to LED0, LED1, IRTX drive and IRRX input.
13	11	VDCX3	3x Charge-Pump Output. Connect a 2nF external capacitor between this pin and ground. No devices other than the capacitor should be connected to this pin.
8	6	$\overline{\text{RESET}}$	Digital, Active-Low, Reset Input/Output. The MAXQ305 remains in reset as long as this pin is low and begins executing from the Utility ROM at address 8000h when this pin returns to a high state. This pin includes a pullup current source; if this pin is driven by an external device, it should be driven by an open-drain source capable of sinking in excess of 4mA. This pin may be left unconnected if there is no need to place the MAXQ305 in a reset state using an external signal. This pin is driven low as an output when an internal reset condition occurs.
6	4	HFXOUT	High-Frequency Crystal Input Pins. Connect an external crystal or resonator between HFXIN and HFXOUT for use as the high-frequency system clock source. Alternatively, connect HFXOUT to ground when an external, high-frequency clock source is connected to the HFXIN pin.
7	5	HFXIN	
IR FUNCTION PINS			
44	38	IRRX	IR Receive Input. IR receiver pin.
45	39	IRTX	IR Transmit Output. Active-low IR transmit pin. This pin defaults to a high-impedance input with the weak pullup disabled during all forms of reset. Software must configure this pin after release from reset to remove the high-impedance input condition.

Low-Voltage Microcontroller with Infrared Module

Pin Description (continued)

PIN		NAME	FUNCTION	
BARE DIE	TQFN			
GENERAL-PURPOSE I/O AND SPECIAL FUNCTION PINS				
		<p>Port 0 General-Purpose Digital I/O Pins. These port pins function as general-purpose I/O pins with their input and output states controlled by the PDO, PO0, and PI0 registers. All port pins default to high-impedance mode after a reset. Software must configure these pins after release from reset to remove the high-impedance condition. All special functions must be enabled from software before they can be used.</p>		
		GPIO PORT PIN	SPECIAL FUNCTIONS	
39	33	P0.0/INT0/IRTXM	P0.0	INT0/IR Modulator Output
38	32	P0.1/INT1/RX0	P0.1	INT1/USART 0 Receive
37	31	P0.2/INT2/TX0	P0.2	INT2/USART 0 Transmit
35	30	P0.3/INT3/RX1	P0.3	INT3/USART 1 Receive
33	29	P0.4/INT4/TX1	P0.4	INT4/USART 1 Transmit
32	28	P0.5/INT5/TBA0/TBA1	P0.5	INT5/Type B Timer 0 Pin A or Type B Timer 1 Pin A
30	27	P0.6/INT6/TBB0	P0.6	INT6/Type B Timer 0 Pin B
29	26	P0.7/INT7/TBB1	P0.7	INT7/Type B Timer 1 Pin B
		<p>Port 1 General-Purpose Digital I/O Pins. These port pins function as general-purpose I/O pins with their input and output states controlled by the PD1, PO1, and PI1 registers. All port pins default to high-impedance mode after a reset. Software must configure these pins after release from reset to remove the high-impedance condition. All special functions must be enabled from software before they can be used (Note that P1.6 and P1.7 do not support the weak pullup mode).</p>		
		GPIO PORT PIN	SPECIAL FUNCTIONS	
1	44	P1.3/INT11	P1.3	INT11
2	1	P1.2/INT10	P1.2	INT10
3	2	P1.1/INT9	P1.1	INT9
4	3	P1.0/INT8	P1.0	INT8
46	40	P1.7/INT15/LED1	P1.7 (No weak pullup mode)	INT15/LED1 Output
47	41	P1.6/INT14/LED0	P1.6 (No weak pullup mode)	INT14/LED0 Output
48	42	P1.5/INT13	P1.5	INT13
49	43	P1.4 / INT12	P1.4	INT12

Low-Voltage Microcontroller with Infrared Module

Pin Description (continued)

PIN		NAME	FUNCTION	
BARE DIE	TQFN			
			<p>Port 2 General-Purpose Digital I/O Pins. These port pins function as general-purpose I/O pins with their input and output states controlled by the PD2, PO2 and PI2 registers. All port pins default to high-impedance mode after a reset. Software must configure these pins after release from reset to remove the high-impedance condition. All special functions must be enabled from software before they can be used.</p>	
			GPIO PORT PIN	SPECIAL FUNCTION
9	7	P2.0/INT16/MOSI	P2.0	INT16/SPI Master Out Slave In
10	8	P2.1/INT17/MISO	P2.1	INT17/SPI Master In Slave Out
11	9	P2.2/INT18/SCLK	P2.2	INT18/SPI Clock
12	10	P2.3/INT19/SSEL	P2.3	INT19/SPI Slave Select
24	22	P2.4/INT20/TCK	P2.4	INT20/JTAG Test Clock
25	23	P2.5/INT21/TDI	P2.5	INT21/JTAG Test Data In
27	24	P2.6/INT22/TMS	P2.6	INT22/JTAG Test Mode Select
28	25	P2.7/INT23/TDO	P2.7	INT23/JTAG Test Data Out
			<p>Port 3 General-Purpose Digital I/O Pins with Interrupt Capability. These port pins function as general-purpose I/O pins with their input and output states controlled by the PD3, PO3 and PI3 registers. All port pins default to high-impedance mode after a reset. Software must configure these pins after release from reset to remove the high-impedance condition. All external interrupts must be enabled from software before they can be used.</p>	
			GPIO PORT PIN	EXTERNAL INTERRUPT
20	18	P3.0/INT24	P3.0	INT24
21	19	P3.1/INT25	P3.1	INT25
22	20	P3.2/INT26	P3.2	INT26
23	21	P3.3/INT27	P3.3	INT27
26, 34, 36	—	N.C.	No Connection.	
40	34	P3.4/INT28	P3.4	INT28
41	35	P3.5/INT29	P3.5	INT29
42	36	P3.6/INT30	P3.6	INT30
43	37	P3.7/INT31	P3.7	INT31

Low-Voltage Microcontroller with Infrared Module

Detailed Description

The MAXQ305 microcontroller provides integrated, low-cost solutions that simplify the design of IR communications equipment such as universal remote controls. Standard features include the highly optimized, single-cycle, MAXQ 16-bit RISC core, 80KB of program flash memory, 2KB of data RAM, a soft stack, 16 general-purpose registers, and three data pointers. The MAXQ core offers the industry's best MIPS/mA rating, allowing developers to achieve the same performance as competing microcontrollers at substantially lower clock rates. Combining reduced active-mode current with the MAXQ305 stop-mode current (0.4 μ A, typical) results in increased battery life. Application-specific peripherals include flexible timers for generating IR carrier frequencies and modulation, a high-current IR drive pin, two LED drive pins, general-purpose I/O pins ideal for keypad matrix input, and a power-fail-detection circuit to notify the application when the supply voltage is nearing the minimum operating voltage of the microcontroller.

At the heart of the MAXQ305 is the MAXQ 16-bit RISC core. The MAXQ305 operates from DC to 12MHz (with an internal system clock of 4MHz maximum in Green Mode) and most instructions execute in a single clock cycle, enabling nearly 1MIPS/MHz operation. When active device operation is not required, an ultra-low-power stop mode can be invoked from software, resulting in quiescent current consumption of less than 0.4 μ A (typ) and 2.0 μ A (max). The combination of high-performance instructions and ultra-low stop-mode current increases battery life over competing microcontrollers. An integrated POR circuit with brownout support resets the device to a known condition following a power-up cycle or brownout condition. Additionally, a power-fail warning flag is set and a power-fail interrupt can be generated when the system voltage falls below the power-fail warning voltage, V_{PFW} . The power-fail warning feature allows the application to notify the user that the system supply is low and appropriate action should be taken.

Microprocessor

The MAXQ305 is based on Maxim's low-power, 16-bit MAXQ family of RISC cores. The core supports the Harvard memory architecture with separate 16-bit program and data address buses. A fixed 16-bit instruction word is standard, but data can be arranged in 8 or 16 bits. The

MAXQ core is implemented as a pipelined processor with performance approaching 1MIPS/MHz. The 16-bit data path is implemented around register modules, and each register module contributes specific functions to the core. The accumulator module consists of sixteen 16-bit registers and is tightly coupled with the arithmetic logic unit (ALU). A configurable soft stack supports program flow.

Execution of instructions is triggered by data transfer between functional register modules or between a functional register module and memory. Because data movement involves only source and destination modules, circuit-switching activities are limited to active modules only. For power-conscious applications, this approach localizes power dissipation and minimizes switching noise. The modular architecture also provides a maximum of flexibility and reusability that is important for a microprocessor used in embedded applications.

The MAXQ instruction set is highly orthogonal. All arithmetical and logical operations can use any register in conjunction with the accumulator. Data movement is supported from any register to any other register. Memory is accessed through specific data-pointer registers with automatic increment/decrement support.

Power Conditioning

The MAXQ305 uses a power conditioning block to provide the various voltage levels and current sources for the micro core, peripherals and IR diode. To support this, four additional pins are required to provide external caps for the charge pump. [Figure 1](#) illustrates the generalized architecture of the power conditioning block.

To conserve power, the main charge pump is not enabled at all times. Instead a 1.7V comparator enables the charge pump only long enough to achieve the 1.7V needed to drive the IR diode. This voltage level is then

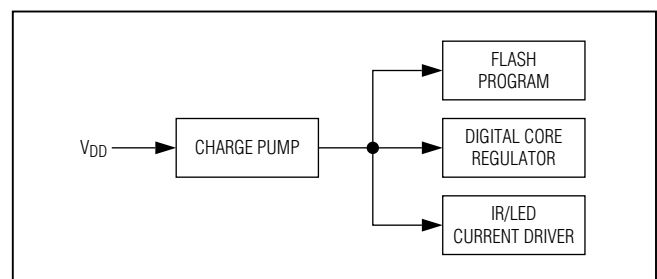

Figure 1. Analog Power Conditioning Block

Low-Voltage Microcontroller with Infrared Module

used to derive the 1.6V minimum crystal oscillator voltage and the 1.4V ($\pm 0.2V$) core voltage.

To support flash program and erase operations, the power conditioning block bumps the main charge-pump voltage output up slightly and muxes the analog LDO output to the flash supply pins to provide adequate voltage levels to the flash to support programming. The IR diode should not be activated when programming the flash as the current capacity supplied by the main charge pump well capacitor is used to supply the flash with sufficient current in this mode. This makes flash program/erase and IR diode operation mutually exclusive.

Memory

The MAXQ305 incorporates several memory types that include the following:

- 80KB program flash memory
- 2KB SRAM data memory
- 6KB utility ROM
- Soft stack

Memory Protection

The optional memory-protection feature separates code memory into three areas: system, user loader, and user application. Code in the system area can be kept confidential. Code in the user areas can be prevented from reading and writing system code. The user loader can also be protected from user application code.

Memory protection is implemented using privilege levels for code. Each area has an associated privilege level. RAM/ROM are assigned privilege levels as well. See [Table 1](#).

Stack Memory

The soft stack stores program return addresses (for subroutine calls and interrupt handling) and other general-purpose data. This soft stack is located in the 2KB SRAM data memory, which means that the SRAM

data memory must be shared between the soft stack and general-purpose application data storage. However, the location and size of the soft stack is determined by the user, providing maximum flexibility when allocating resources for a particular application. The stack is used automatically by the processor when the CALL, RET, and RETI instructions are executed and when an interrupt is serviced. An application can also store and retrieve values explicitly using the stack by means of the PUSH, POP, and POPI instructions.

The SP pointer indicates the current top of the stack, which initializes by default to the top of the SRAM data memory. As values are pushed onto the stack, the SP pointer decrements, which means that the stack grows downward towards the bottom (lowest address) of the data memory. Popping values off the stack causes the SP pointer value to increase.

Utility ROM

The utility ROM is a 6KB block of internal ROM memory located in program space beginning at address 8000h. This ROM includes the following routines:

- In-system programming (bootstrap loader) using JTAG interface
- In-circuit debugging routines using JTAG interface
- Production test routines (internal memory tests, memory loader, etc.) These are used for internal testing only, and are generally of no use to the end-application developer.
- User-callable routines for in-application flash programming, buffer copying and fast table lookup. More information on these routines can be found in the *MAXQ305 User's Guide*.

Following any reset, execution begins in the utility ROM at address 8000h. At this point, unless loader mode or test mode has been invoked (which requires special programming via the JTAG interface), the utility ROM always automatically jumps to location 0000h, which is

Table 1. Memory Areas and Associated Maximum Privilege Levels

AREA	PAGE ADDRESS	MAXIMUM PRIVILEGE LEVEL
System	0 to ULDR-1	High
User Loader	ULDR to UAPP-1	Medium
User Application	UAPP to top	Low
Utility ROM	N/A	High
Other (RAM)	N/A	Low

Low-Voltage Microcontroller with Infrared Module

the beginning of user application code in program flash memory.

Some applications require protection against unauthorized viewing of program code memory. For these applications, access to in-system programming, in-application programming or in-circuit debugging functions is prohibited until a password has been supplied. Three different password locks are provided, each of which can be used to protect a different area of memory (system memory, user loader and user application). Each password lock is controlled by a 16-word area of flash memory; if the password is set to all FFFFh values or all 0000h values, the password is disabled. Otherwise, the password is active and must be matched by the user of the bootloader or debugger before access is granted to the corresponding area of flash program memory. Refer to the *MAXQ305 User's Guide* for more details.

Watchdog Timer

The internal watchdog timer greatly increases system reliability. The timer resets the device if software execution is disturbed. The watchdog timer is a free-running counter designed to be periodically reset by the application software. If software is operating correctly, the counter is periodically reset and never reaches its maximum count. However, if software operation is interrupted, the timer does not reset, triggering a system reset and optionally a watchdog timer interrupt. This protects the system against electrical noise or electrostatic discharge (ESD) upsets that could cause uncontrolled processor operation. The internal watchdog timer is an upgrade to older designs with external watchdog devices, reducing system cost and simultaneously increasing reliability.

The watchdog timer functions as the source of both the watchdog timer timeout and the watchdog timer reset. The timeout period can be programmed in a range of 2^{15} to 2^{24} system clock cycles. An interrupt is generated when the timeout period expires if the interrupt is enabled. All

watchdog timer resets follow the programmed interrupt timeouts by 512 system clock cycles. If the watchdog timer is not restarted for another full interval in this time period, a system reset occurs when the reset timeout expires. See [Table 2](#).

IR Carrier Generation and Modulation Timer

The dedicated IR timer/counter module simplifies low-speed infrared (IR) communication. The IR timer implements two pins (IRTX and IRRX) for supporting IR transmit and receive, respectively. The IRTX pin has no corresponding port pin designation, so the standard PD, PO, and PI port control status bits are not present. However, the IRTX pin output can be manipulated high or low using the PWCN.IRTXOUT and PWCN.IRTXOE bits when the IR timer is not enabled (i.e., IREN = 0).

The IR timer is composed of a carrier generator and a carrier modulator. The carrier generation module uses the 16-bit IR carrier register (IRCA) to define the high and low time of the carrier through the IR carrier high byte (IRCAH) and IR carrier low byte (IRCAL). The carrier modulator uses the IR data bit (IRDATA) and IR modulator time register (IRMT) to determine whether the carrier or the idle condition is present on IRTX.

The IR timer is enabled when the IR enable bit (IREN) is set to 1. The IR Value register (IRV) defines the beginning value for the carrier modulator. During transmission, the IRV register is initially loaded with the IRMT value and begins down counting towards 0000h, whereas in receive mode it counts upward from the initial IRV register value. During the receive operation, the IRV register can be configured to reload with 0000h when capture occurs on detection of selected edges or can be allowed to continue free-running throughout the receive operation. An overflow occurs when the IR timer value rolls over from 0FFFFh to 0000h. The IR overflow flag (IROV) is set to 1 and an interrupt is generated if enabled (IRIE = 1).

Table 2. Watchdog Interrupt Timeout

WD[1:0]	WATCHDOG CLOCK	WATCHDOG INTERRUPT TIMEOUT	WATCHDOG RESET AFTER WATCHDOG INTERRUPT (μ s)
00	Sysclk/ 2^{15}	2.7ms	42.7
01	Sysclk/ 2^{18}	21.9ms	42.7
10	Sysclk/ 2^{21}	174.7ms	42.7
11	Sysclk/ 2^{24}	1.4s	42.7

Low-Voltage Microcontroller with Infrared Module

Carrier Generation Module

The IRCAH byte defines the carrier high time in terms of the number of IR input clocks, whereas the IRCAL byte defines the carrier low time.

- IR Input Clock (f_{IRCLK}) = $f_{SYS}/2^{IRDIV[1:0]}$
- Carrier Frequency ($f_{CARRIER}$) = $f_{IRCLK}/(IRCAH + IRCAL + 2)$
- Carrier High Time = $IRCAH + 1$
- Carrier Low Time = $IRCAL + 1$
- Carrier Duty Cycle = $(IRCAH + 1)/(IRCAH + IRCAL + 2)$

During transmission, the IRCA register is latched for each IRV down-count interval, and is sampled along with the IRTXPOL and IRDATA bits at the beginning of each new IRV down-count interval so that duty-cycle variation and frequency shifting is possible from one interval to the next, which is illustrated in [Figure 2](#).

[Figure 3](#) illustrates the basic carrier generation and its path to the IRTX output pin. The IR transmit polarity bit (IRTXPOL) defines the starting/idle state and the carrier polarity of the IRTX pin when the IR timer is enabled.

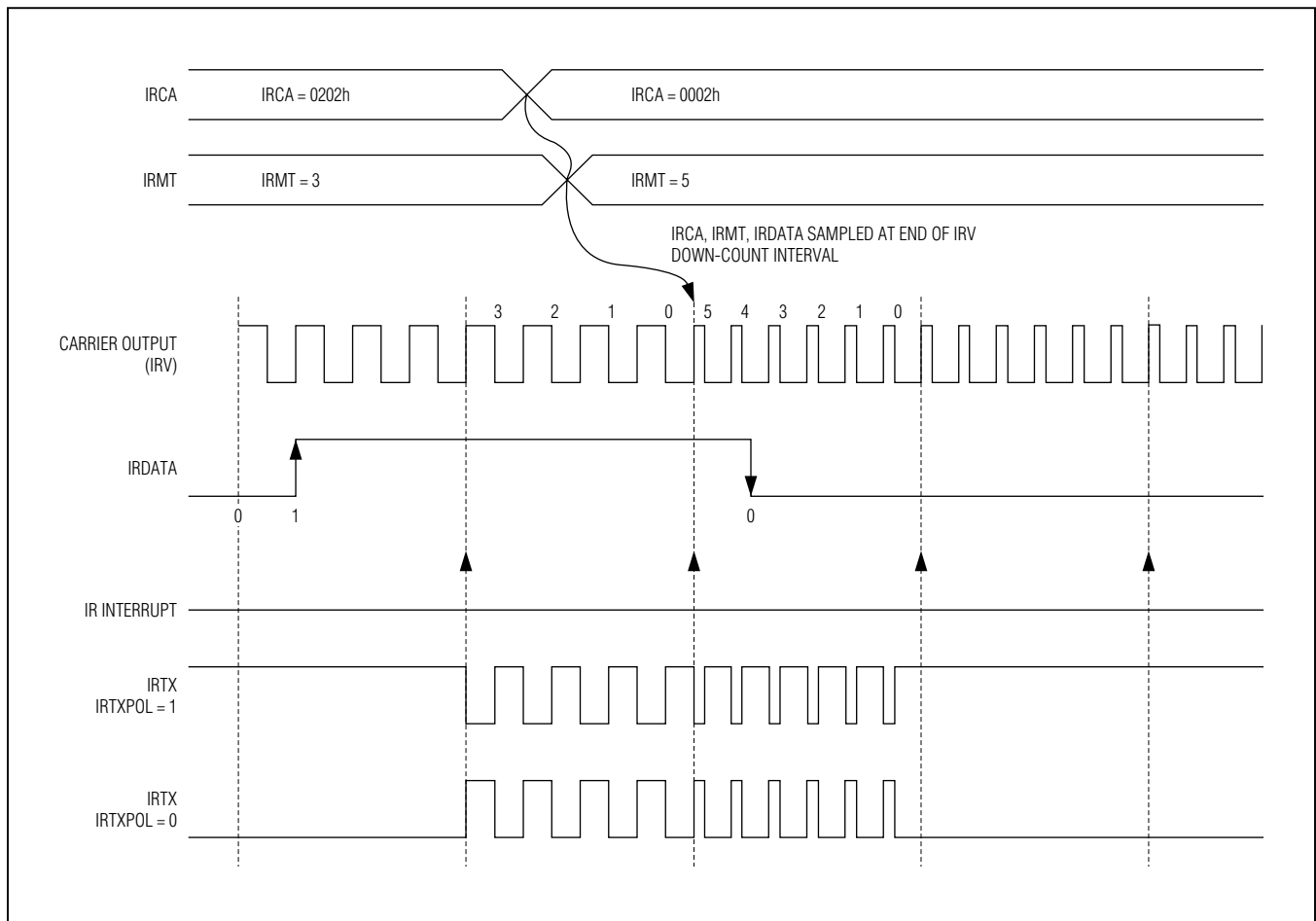

Figure 2. IR Transmit Frequency Shifting Example (IRCFME=0)

Low-Voltage Microcontroller with Infrared Module

IR Transmission

During IR transmission (IRMODE = 1), the carrier generator creates the appropriate carrier waveform, while the carrier modulator performs the modulation. The carrier modulation can be performed as a function of carrier cycles or IRCLK cycles dependent on the setting of the IRCFME bit. When IRCFME = 0, the IRV down counter is clocked by the carrier frequency and thus the modulation is a function of carrier cycles. When IRCFME = 1, the IRV down counter is clocked by IRCLK, allowing carrier modulation timing with IRCLK resolution.

The IRTXPOL bit defines the starting/idle state as well as the carrier polarity for the IRTX pin. If IRTXPOL = 1, the IRTX pin is set to a logic-high when the IR timer module is enabled. If IRTXPOL = 0, the IRTX pin is set to a logic-low when the IR timer is enabled.

A separate register bit, IR data (IRDATA), is used to determine whether the carrier generator output is output to the IRTX pin for the next IRMT carrier cycles. When IRDATA = 1, the carrier waveform (or inversion of this waveform if IRTXPOL = 1) is output on the IRTX pin during the next IRMT cycles. When IRDATA = 0, the idle condition, as defined by IRTXPOL, is output on the IRTX pin during the next IRMT cycles.

The IR timer acts as a down counter in transmit mode. An IR transmission starts when the IREN bit is set to 1 when IRMODE = 1; when the IRMODE bit is set to 1 when IREN = 1; or when IREN and IRMODE are both set to 1 in the same instruction. The IRMT and IRCA registers, along

with the IRDATA and IRTXPOL bits, are sampled at the beginning of the transmit process and every time the IR timer value reloads its value. When the IRV reaches 0000h value, on the next carrier clock, it does the following:

- 1) Reloads IRV with IRMT.
- 2) Samples IRCA, IRDATA, and IRTXPOL.
- 3) Generates IRTX accordingly.
- 4) Sets IRIF to 1.
- 5) Generates an interrupt to the CPU if enabled (IRIE = 1).

To terminate the current transmission, the user can switch to receive mode (IRMODE = 0) or clear IREN to 0.

Carrier Modulation Time = IRMT + 1 carrier cycles

IR Transmit—Independent External Carrier and Modulator Outputs

The normal transmit mode modulates the carrier based upon the IRDATA bit. However, the user has the option to input the modulator (envelope) on an external pin if desired. If the IRENV[1:0] bits are configured to 01b or 10b, the modulator/envelope is output to the IRTXM pin. The IRDATA bit is output directly to the IRTXM pin (if IRTXPOL = 0) on each IRV down-count interval boundary just as if it were being used to internally modulate the carrier frequency. If IRTXPOL = 1, the inverse of the IRDATA bit is output to the IRTXM pin on the IRV interval down-count boundaries. See [Figure 4](#). When the envelope mode is enabled, it is possible to output either the modulated (IRENV[1:0] = 01b) or unmodulated (IRENV[1:0] = 10b) carrier to the IRTX pin.

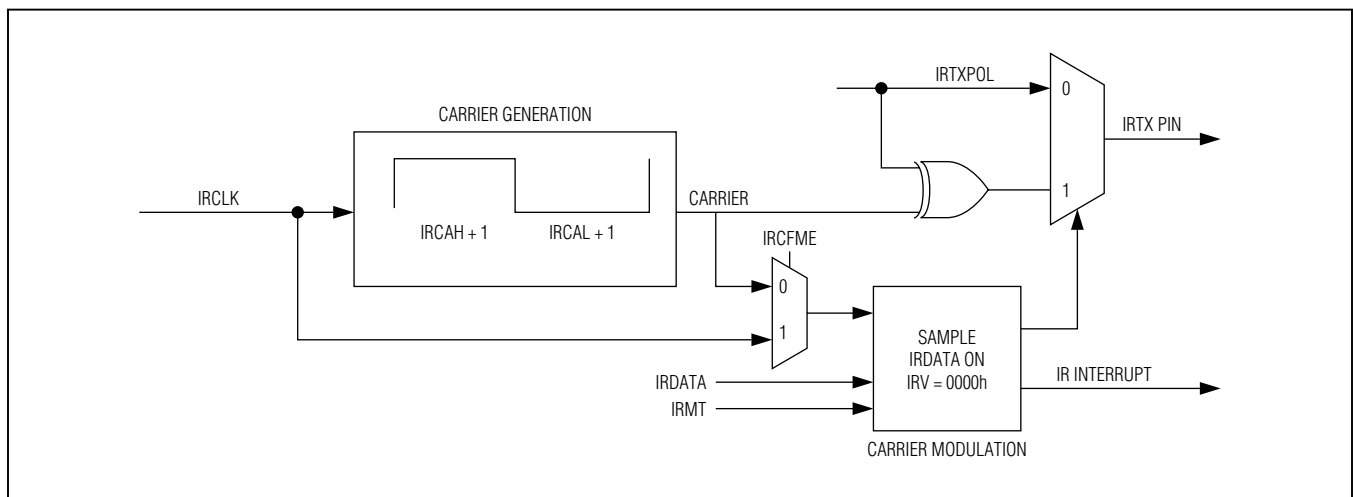

Figure 3. IR Transmit Carrier Generation and Carrier Modulator Control

Low-Voltage Microcontroller with Infrared Module

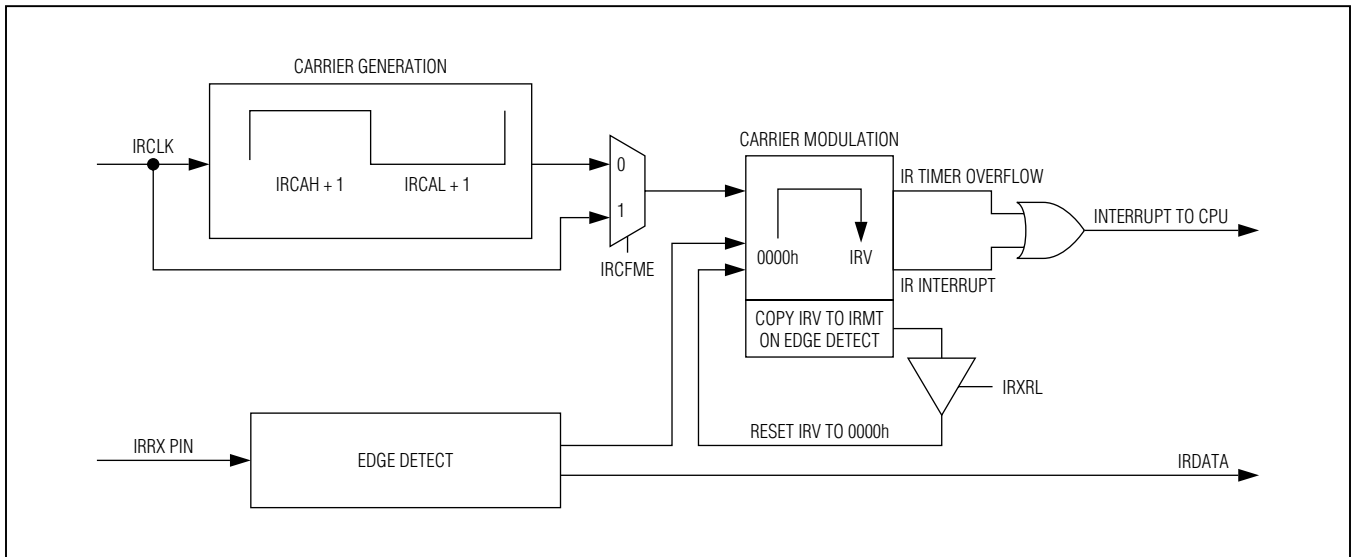

Figure 4. IR Capture

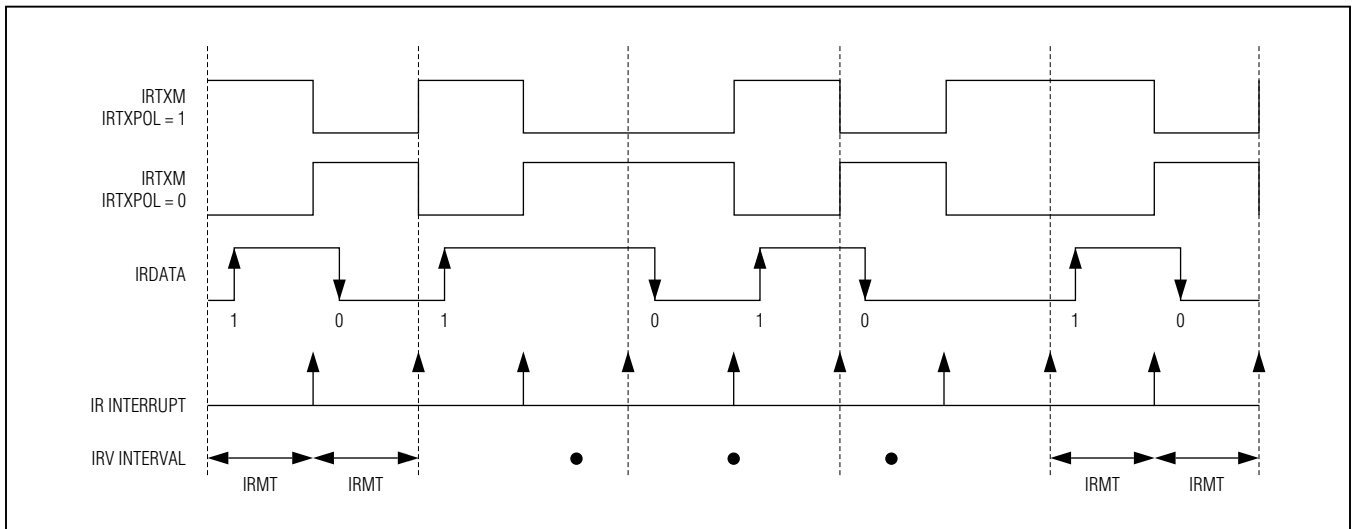

Figure 5. External IRTXM (Modulator) Output

IR Receive

When configured in receive mode ($IRMODE = 0$), the IR hardware supports the **IRRX** capture function (Figure 5). The **IRRXSEL[1:0]** bits define which edge(s) of the **IRRX** pin should trigger the IR timer capture function.

The IR module starts operating in the receive mode when $IRMODE = 0$ and $IREN = 1$. Once started, the IR timer (**IRV**) starts up counting from **0000h** when a qualified

capture event as defined by **IRRXSEL** happens. The **IRV** register is, by default, counting carrier cycles as defined by the **IRCA** register. However, the IR carrier frequency detect (**IRCFME**) bit can be set to 1 to allow clocking of the **IRV** register directly with the **IRCLK** for finer resolution. When $IRCFME = 0$, the **IRCA** defined carrier is counted by **IRV** (Figure 6). When $IRCFME = 1$, the **IRCLK** clocks the **IRV** register.

Low-Voltage Microcontroller with Infrared Module

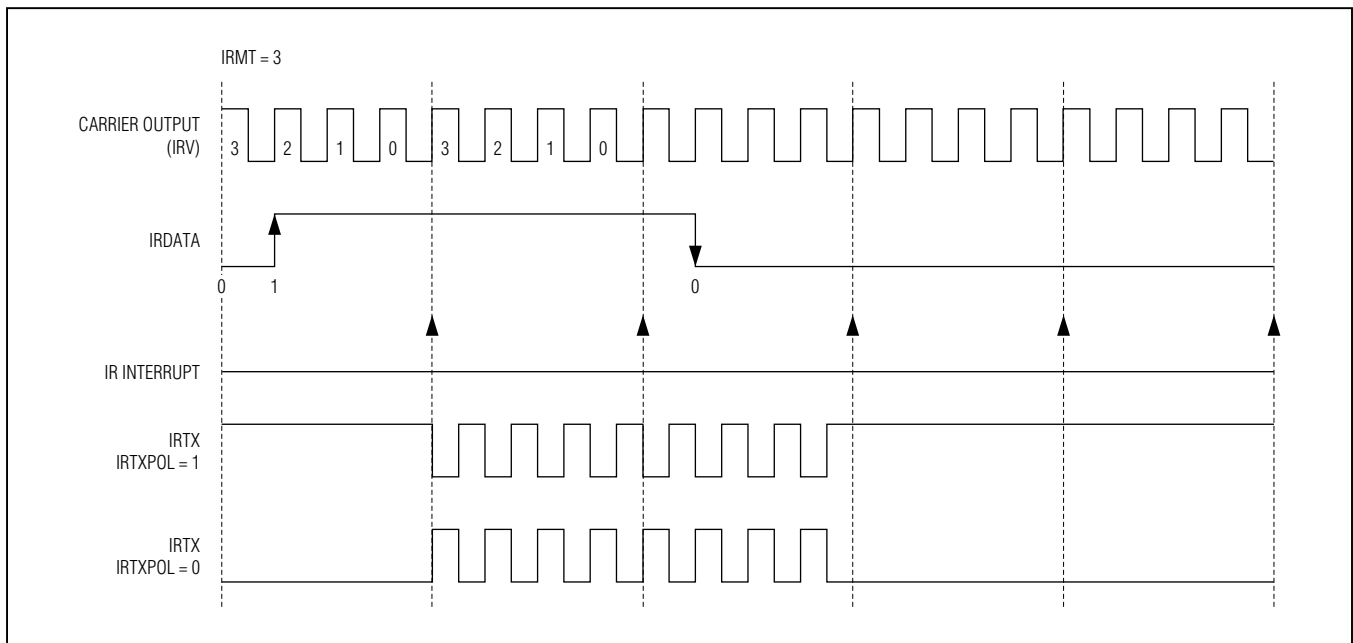

Figure 6. IR Transmission Waveform (IRCFME = 0)

On the next qualified event, the IR module does the following:

- 1) Captures the IRRX pin state and transfers its value to IRDATA. If a falling edge occurs, IRDATA = 0. If a rising edge occurs, IRDATA = 1.
- 2) Transfers its current IRV value to the IRMT.
- 3) Resets IRV content to 0000h (if IRXRL = 1).
- 4) Continues counting again until the next qualified event.

If the IR timer value rolls over from 0FFFFh to 0000h before a qualified event happens, the IR timer overflow (IROV) flag is set to 1 and an interrupt is generated, if enabled. The IR module continues to operate in receive mode until it is stopped by switching into transmit mode (IRMODE = 1) or clearing IREN = 0.

Carrier Burst-Count Mode

A special mode reduces the CPU processing burden when performing IR learning functions. Typically, when operating in an IR learning capacity, some number of carrier cycles are examined for frequency determination. Once the frequency has been determined, the IR receive function can be reduced to counting the number of

carrier pulses in the burst and the duration of the combined mark-space time within the burst. To simplify this process, the receive burst-count mode (as enabled by the RXBCNT bit) can be used. When RXBCNT = 0, the standard IR receive capture functionality is in place. When RXBCNT = 1, the IRV capture operation is disabled and the interrupt flag associated with the capture no longer denotes a capture. In the carrier burst-count mode, the IRMT register only counts qualified edges. The IRIF interrupt flag (normally used to signal a capture when RXBCNT = 0) now becomes set if two IRCA cycles elapse without getting a qualified edge. The IRIF interrupt flag thus denotes absence of the carrier and the beginning of a space in the receive signal. When the RXBCNT bit is changed from 0 to 1, the IRMT register is set to 0001h. The IRCFME bit is still used to define whether the IRV register is counting system IRCLK clocks or IRCA-defined carrier cycles. The IRXRL bit defines whether the IRV register is reloaded with 0000h on detection of a qualified edge (per the IRXSEL[1:0] bits). Figure 7 and the descriptive sequence embedded in the figure illustrate the expected usage of the receive burst-count mode.

Low-Voltage Microcontroller with Infrared Module

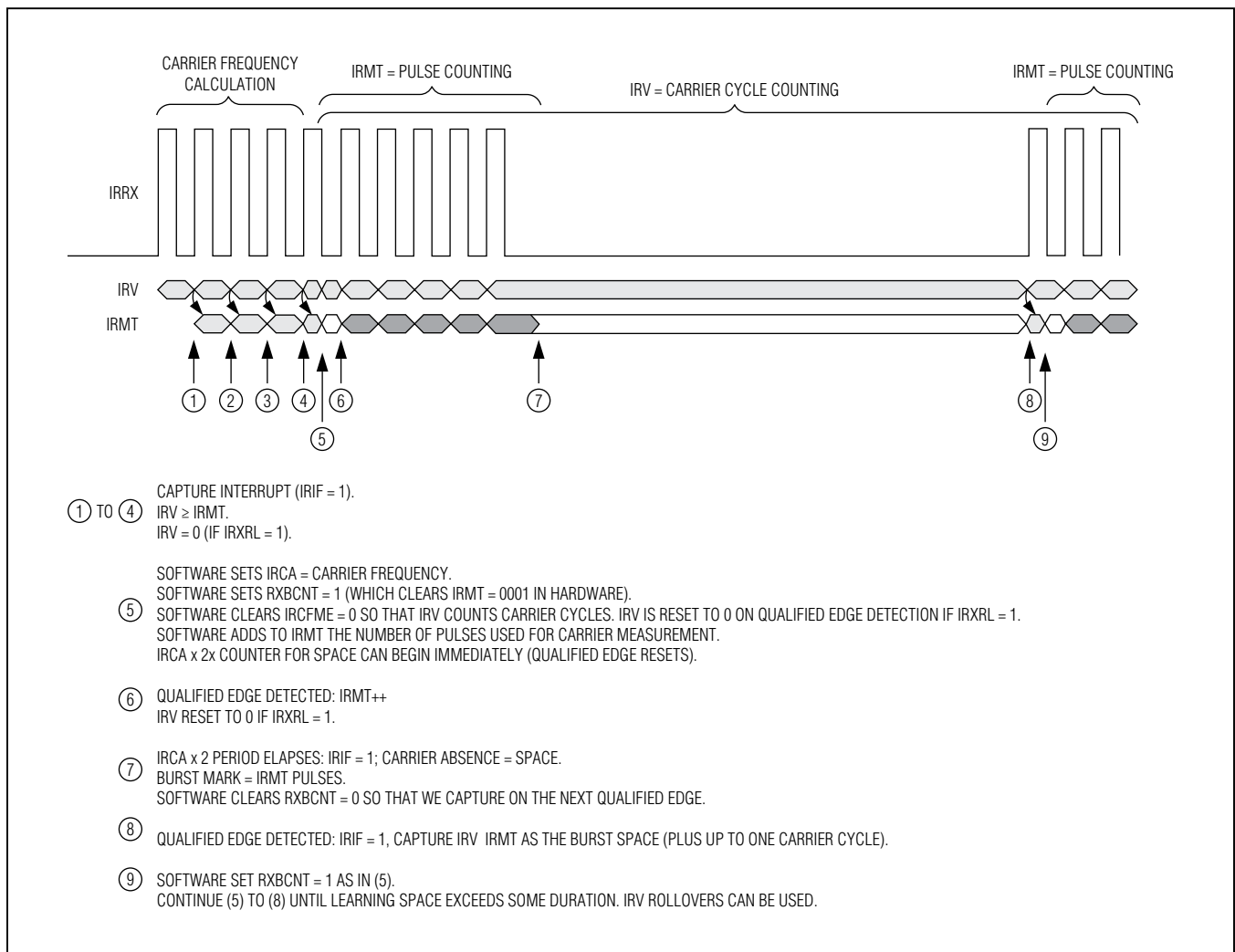

Figure 7. Receive Burst-Count Example

16-Bit Timers/Counters

The MAXQ305 provides two timers/counters that support the following functions:

- 16-bit timer/counter
- 16-bit up/down autoreload
- Counter function of external pulse
- 16-bit timer with capture
- 16-bit timer with compare
- Input/output enhancements for pulse-width modulation

- Set/reset/toggle output state on comparator match
- Prescaler with 2^n divider (for $n = 0, 2, 4, 6, 8, 10$)

USARTS

The MAXQ305 provides two Universal Synchronous/Asynchronous Receiver/Transmitter (USART) peripherals that include the following features:

- 2-wire interface
- Full-duplex operation for asynchronous data transfers
- Half-duplex operation for synchronous data transfers

Low-Voltage Microcontroller with Infrared Module

- Programmable interrupt when transmit or receive data operation completes
- Independent programmable baud-rate generator
- Optional 9th bit parity support
- Start/stop bit support

Serial Peripheral Interface (SPI)

The integrated SPI provides an independent serial communication channel that communicates synchronously with peripheral devices in a multiple master or multiple slave system. The interface allows access to a 4-wire, full-duplex serial bus, and can be operated in either master mode or slave mode. Collision detection is provided when two or more masters attempt a data transfer at the same time.

The maximum SPI master transfer rate is $\text{Sysclk}/2$. When operating as an SPI slave, the MAXQ305 can support up to a $\text{Sysclk}/4$ SPI transfer rate. Data is transferred as an 8-bit or 16-bit value, MSB first. In addition, the SPI module supports configuration of active $\overline{\text{SSEL}}$ state (active-low or active-high) through the slave active select.

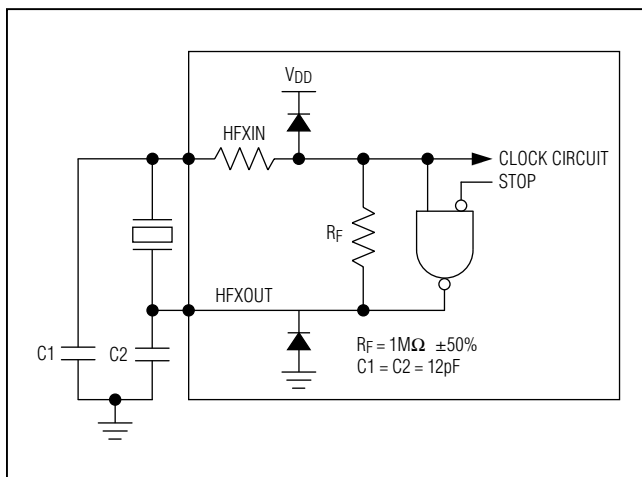

Figure 8. On-Chip Oscillator

Table 3. USART Mode Details

MODE	TYPE	START BITS	DATA BITS	STOP BITS
Mode 0	Synchronous	N/A	8	N/A
Mode 1	Asynchronous	1	8	1
Mode 2	Asynchronous	1	8 + 1	1
Mode 3	Asynchronous	1	8 + 1	1

General-Purpose I/O

The port pins have the following features:

- CMOS output drivers
- Schmitt trigger inputs
- Optional weak pullups to V_{DD} when operating in input mode (with the exception of P1.6 and P1.7)

While the microcontroller is in a reset state, all port pins become high impedance with weak pullups disabled, unless otherwise noted. From a software perspective, each port appears as a group of peripheral registers with unique addresses. Special function pins can also be used as general-purpose I/O pins when the special functions are disabled. For a detailed description of the special functions available for each pin, refer to the *MAXQ305 User's Guide*.

On-Chip Oscillator

An external quartz crystal or a ceramic resonator can be connected between HFXIN and HFXOUT on the MAXQ305, as illustrated in [Figure 8](#). Noise at HFXIN and HFXOUT can adversely affect on-chip clock timing. It is good design practice to place the crystal and capacitors near the oscillator circuitry and connect HFXIN and HFXOUT to ground with a direct short trace. The typical values of external capacitors vary with the type of crystal to be used and should be initially selected based on the load capacitance as suggested by the crystal manufacturer.

ROM Loader

The ROM loader denies access to the system, user loader, or user-application memories unless an area-specific password is provided. The ROM loader is not available in ROM-only versions.

Low-Voltage Microcontroller with Infrared Module

Loading Flash Memory

An internal bootstrap loader allows reloading over a simple JTAG interface. As a result, software can be upgraded in-system, eliminating the need for a costly hardware retrofit when updates are required. Remote software uploads are possible that enable physically inaccessible applications to be frequently updated. The interface hardware can be a JTAG connection to another microcontroller, or a connection to a PC serial port using a serial-to-JTAG converter such as the MAXQJTAG-001, available from Maxim. If in-system programmability is not required, a commercial gang programmer can be used for mass programming. Activating the JTAG interface and loading the test access port (TAP) with the system programming instruction invokes the bootstrap loader. Setting the SPE bit to one during reset through the JTAG interface executes the bootstrap-loader mode program that resides in the utility ROM. When programming is complete, the bootstrap loader can clear the SPE bit and reset the device, allowing the device to bypass the utility ROM and begin execution of the application software.

In addition, the ROM loader also enforces the memory-protection policies. Passwords that are 16 words are required to access the ROM loader interface.

Do not drive the LED or IRTX outputs while programming flash memory.

Loading memory is not possible for ROM-only versions of the device.

In-Circuit Debug and JTAG Interface

Embedded debug hardware and software are developed and integrated to provide full in-circuit debugging capability in a user-application environment. These hardware and software features include the following:

- Debug engine
- Set of registers providing the ability to set breakpoints on register, code, or data using debug service routines stored in ROM

Collectively, these hardware and software features support two modes of in-circuit debug functionality:

- Background mode:
 - CPU is executing the normal user program
 - Allows the host to configure and set up the in-circuit debugger
- Debug mode:
 - Debugger takes over the control of the CPU
 - Read/write accesses to internal registers and memory
 - Single-step of the CPU for trace operation

The interface to the debug engine is the TAP controller, as shown in [Figure 9](#). The interface allows for communication with a bus master that can either be automatic test equipment or a component that interfaces to a higher level test bus as part of a complete system. The communication operates across a 4-wire serial interface from a dedicated TAP that is compatible with the JTAG IEEE Standard 1149. The TAP provides an independent serial channel to communicate synchronously with the host system.

To prevent unauthorized access of the protected memory regions through the JTAG interface, the debug engine prevents modification of the privilege registers and disallows all access to system memory, unless memory protection is disabled. In addition, all services (such as register display or modification) are denied when code is executing inside the system area. The debugger is not available for ROM-only versions of the device.

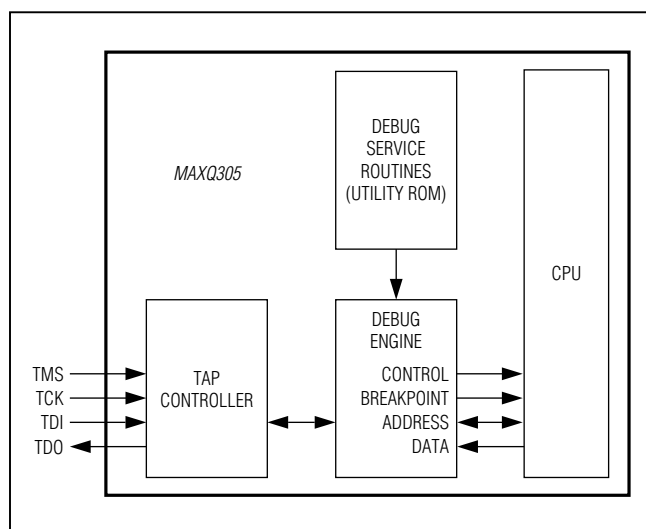

Figure 9. In-Circuit Debugger

Low-Voltage Microcontroller with Infrared Module

Operating Modes

The microcontroller has five power operating modes:

- High performance
- High voltage
- Green
- Idle
- Stop

The device is operating in high-performance mode when $V_{DD} > V_{DD_PFM}$, the internal voltage regulator is enabled ($HVREN = 1$), the high-performance bit is set ($PFMSEL = 1$), and $f_{HFXIN} = 12\text{MHz}$. In this mode $f_{SYSCLK} = 12\text{MHz}$. The high-voltage regulator generates the voltages needed for flash memory programming, which is allowed in this mode.

The device is operating in high-voltage mode when $V_{DD} > V_{DD_HV}$, $HVREN = 1$, $PFMSEL = 0$. In this mode $f_{SYSCLK} = f_{HFXIN}/3$. The high-voltage regulator generates the voltages needed for flash memory programming, which is allowed in this mode.

Green mode is the lowest power mode that allows code execution. In this mode $HVREN = PFMSEL = 0$. In this mode $f_{SYSCLK} = f_{HFXIN}/3$. Flash programming is not allowed in this mode.

Setting the IDLE bit in the CKCN register to 1 invokes the idle mode. Once in idle mode, all resources are preserved and all clocks remain active with the enabled peripherals, and power monitor continues to work, so the processor can exit the idle state using any of the interrupt sources that are enabled. The IDLE bit is cleared automatically once the idle state is exited; allowing the processor to execute the instruction that immediately follows the instruction that set the IDLE bit.

The lowest power mode of operation for the MAXQ305 is stop mode. The user software can enter stop mode any time the microcontroller is in a state where code does not need to be executed. In this mode, CPU state and memories are preserved, but the CPU is not actively running. Wake-up sources include external I/O interrupts, the power-fail warning interrupt, or a power-fail reset. The nanopower ring oscillator is an internal ultra-low-

power (400nA) 8kHz ring oscillator that can be used to drive a wake-up timer that exits stop mode. The wake-up timer is programmable by software in steps of 125 μ s up to approximately 8s.

The power-fail monitor is always on during normal operation. However, it can be selectively disabled during stop mode to minimize power consumption. This feature is enabled using the power-fail monitor disable (PFD) bit in the PWCN register. The reset default state for the PFD bit is 1, which disables the power-fail monitor function during stop mode. If power-fail monitoring is disabled ($PFD = 1$) during stop mode, the circuitry responsible for generating a power-fail warning or reset is shut down and neither condition is detected. Thus, the $V_{DD} < V_{RST}$ condition does not invoke a reset state.

Power-Fail Detection

Figure 10, Figure 11, Figure 12, and Figure 13 show the power-fail detection and response during normal and stop mode operation. If a reset is caused by a power-fail, the power-fail monitor can be set to one of the following intervals:

- Always on—continuous monitoring
- 2¹¹ nanopower ring oscillator clocks (~256ms)
- 2¹² nanopower ring oscillator clocks (~512ms)
- 2¹³ nanopower ring oscillator clocks (~1.024s)

In the case where the power-fail circuitry is periodically turned on, the power-fail detection is turned on for two nanopower ring oscillator cycles. If $V_{DD} > V_{RST}$ during detection, V_{DD} is monitored for an additional nanopower ring oscillator period. If V_{DD} remains above V_{RST} for the third nanopower ring period, the CPU exits the reset state and resumes normal operation from utility ROM at 8000h after satisfying the crystal warm-up period.

If a reset is generated by any other event, such as the RESET pin being driven low externally or the watchdog timer, then the power-fail, internal regulator, and crystal remain on during the CPU reset. In these cases, the CPU exits the reset state in less than 20 external clock cycles after the reset source is removed.

RESET state in less than 20 crystal cycles after the reset source is removed.

Low-Voltage Microcontroller with Infrared Module

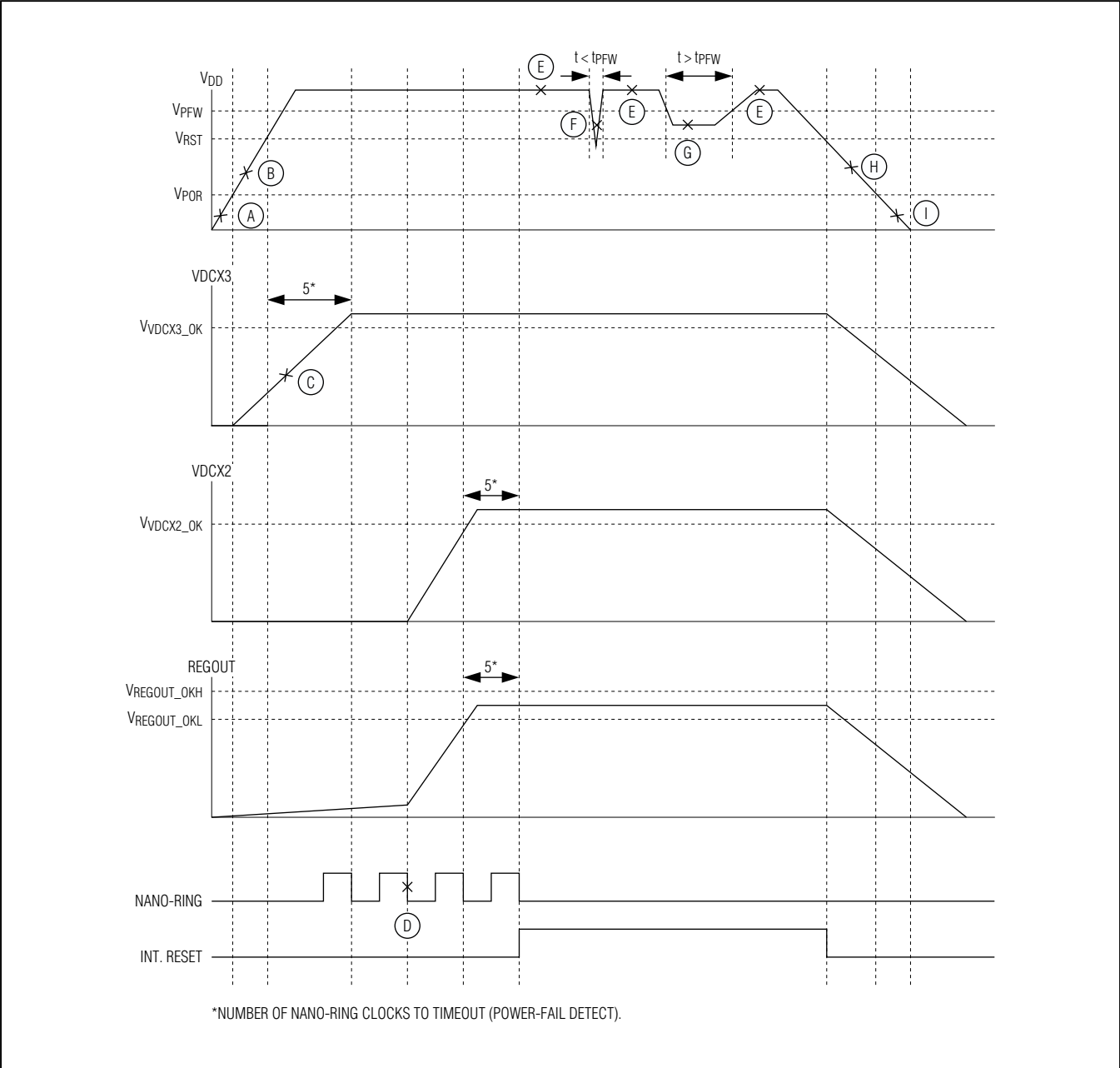

Figure 10. Power-Fail Detection During Normal Operation

Low-Voltage Microcontroller with Infrared Module

Table 4. Power-Fail Detection States During Normal Operation

STATE	POWER-FAIL DETECTOR	REGOUT LDO	BACKUP REGULATOR	CRYSTAL OSCILLATOR	SRAM DATA RETENTION	NOTES
A	OFF	OFF	ON	OFF	—	$V_{DD} < V_{POR}$
B	OFF	OFF	ON	OFF	—	$V_{POR} < V_{DD} < V_{RST}$ nano-ring clock enabled X3 charge pump enabled
C	OFF	OFF	ON	OFF	—	$V_{DCX3} < V_{DCX3_OK}$ Supply Voltage Monitor enabled
D	ON	ON	ON	ON	—	X2 charge pump enabled LDO enabled Crystal oscillator enabled
E	ON	ON	OFF	ON	—	$V_{DCX2} > V_{DCX2_OK}$ $V_{REGOUT} > V_{REGOUT_OK_L}$ Backup regulator disabled CPU assume normal operation
F	ON	ON	OFF	ON	—	Power drop too short. Power-fail not detected
G	ON	ON	OFF	ON	—	$V_{RST} < V_{DD} < V_{PFW}$ PFI is set when $V_{RST} < V_{DD} < V_{PFW}$ and maintains this state for at least t_{PFW} , at which time a power-fail interrupt is generated (if enabled). CPU continues normal operation.
H	ON (periodically)	OFF	ON	OFF	YES	$V_{POR} < V_{DD} < V_{RST}$ Power-fail detected CPU goes into reset Power-fail monitor turned on periodically
I	OFF	OFF	ON	OFF	YES	$V_{DD} < V_{POR}$ Device held in reset, no operation allowed

Low-Voltage Microcontroller with Infrared Module

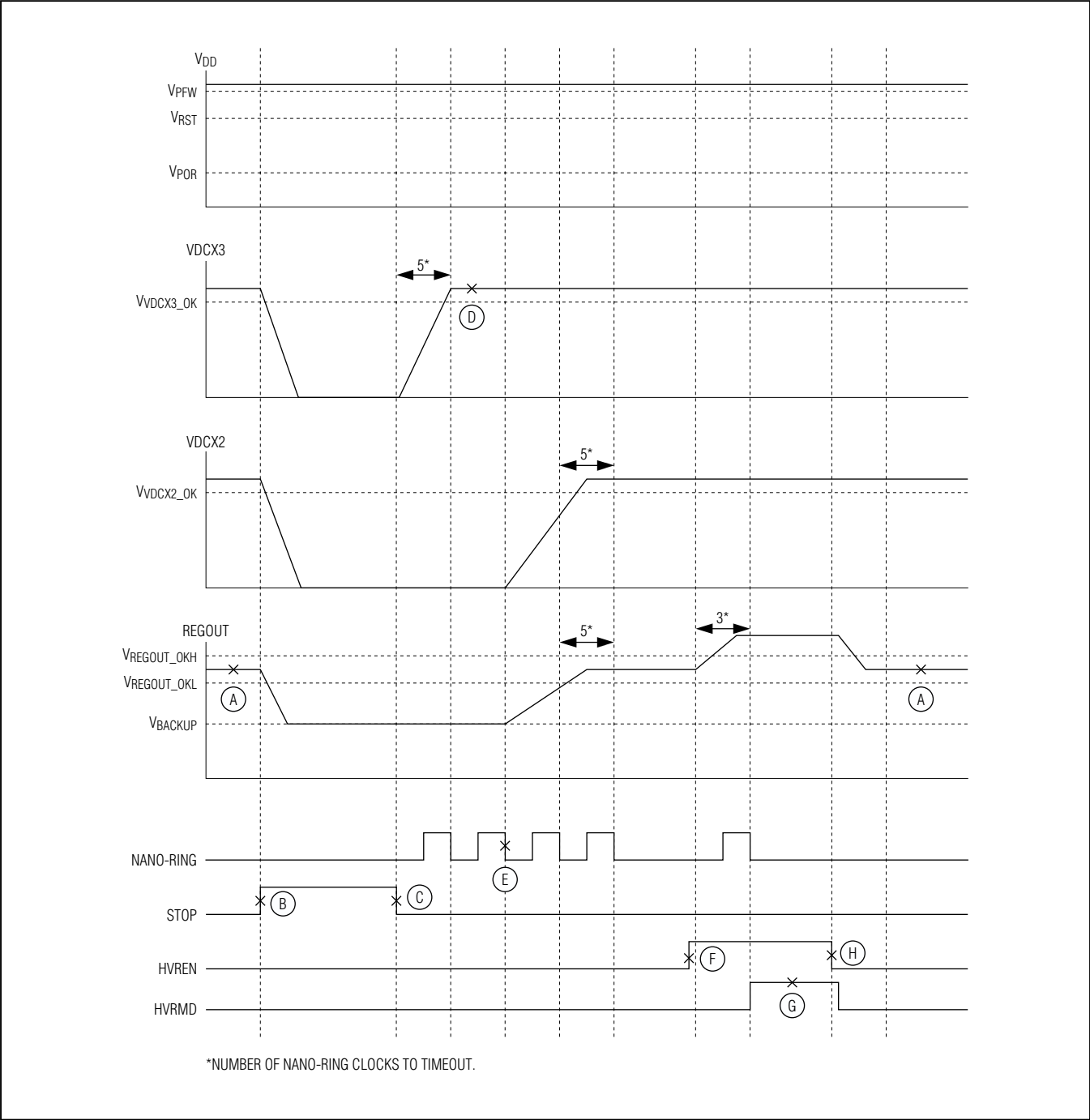

Figure 11. Stop Mode and High Voltage Mode Transition

Low-Voltage Microcontroller with Infrared Module

Table 5. Stop Mode and High Voltage Mode Transition

STATE	POWER-FAIL DETECTOR	REGOUT LDO	BACKUP REGULATOR	CRYSTAL OSCILLATOR	SRAM DATA RETENTION	NOTES
A	ON	ON	OFF	ON	—	$V_{DCX2} > V_{DCX2_OK}$ $V_{REGOUT_OK_L} < V_{REGOUT} < V_{REGOUT_OK_H}$ CPU operates normally Flash writes not allowed
B	OFF	OFF	ON	OFF	YES	Stop mode requested CPU stopped X3 charge pump, X2 charge pump, LDO, Power-fail detector and crystal oscillator disabled Backup regulator enabled
C	OFF	OFF	ON	OFF	YES	Stop mode exit requested nano-ring clock enabled X3 charge pump enabled
D	ON	OFF	ON	OFF	YES	$V_{DCX3} > V_{DCX3_OK}$ Supply Voltage Monitor enabled
E	ON	ON	ON	ON	YES	X2 charge pump enabled LDO enabled Crystal oscillator enabled
F	ON	ON	OFF	ON	—	High voltage mode requested LDO output increased Nano-ring enabled
G	ON	ON	OFF	ON	—	High voltage mode accepted Flash writes allowed
H	ON	ON	OFF	ON	—	Low voltage mode requested Flash writes not allowed

Low-Voltage Microcontroller with Infrared Module

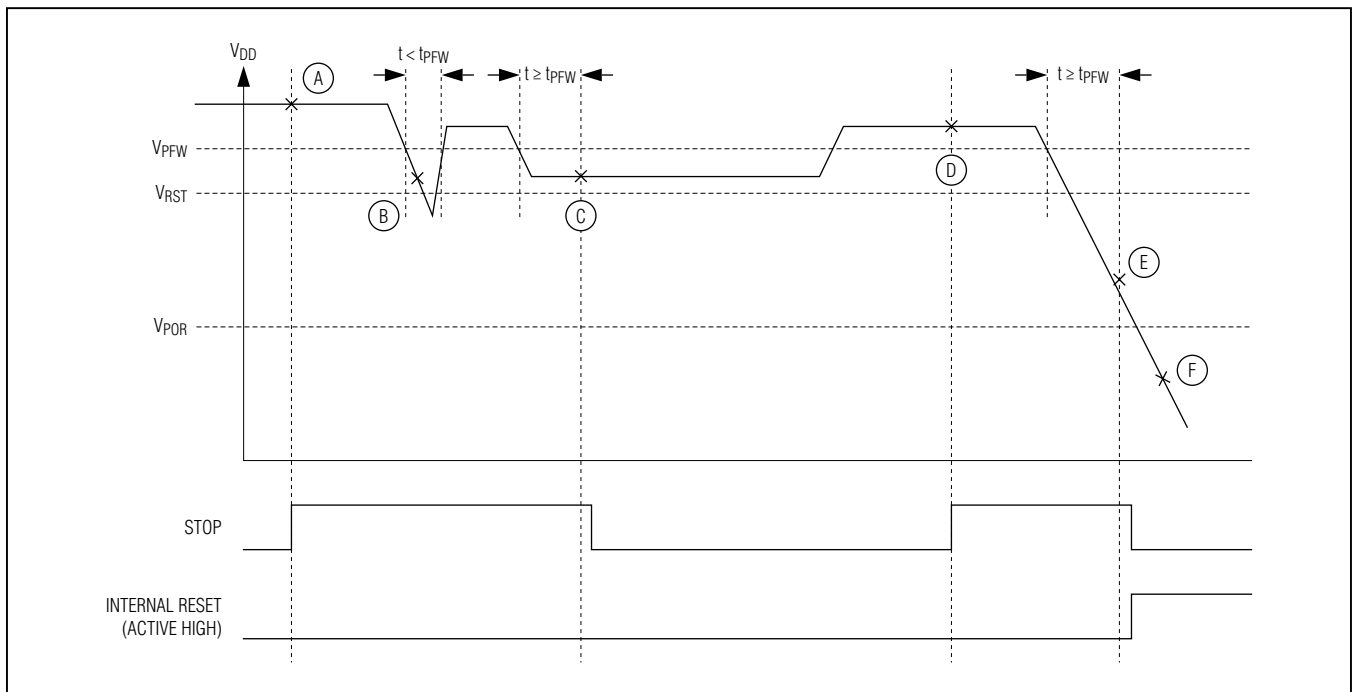

Figure 12. Stop Mode Power-Fail Detection States with Power-Fail Monitor Enabled

Table 6. Stop Mode Power-Fail Detection States with Power-Fail Monitor Enabled

STATE	POWER-FAIL	INTERNAL REGULATOR	CRYSTAL OSCILLATOR	SRAM RETENTION	COMMENTS
A	On	Off	Off	Yes	Application enters stop mode. $V_{DD} > V_{RST}$. CPU in stop mode.
B	On	Off	Off	Yes	Power drop too short. Power-fail not detected.
C	On	On	On	Yes	$V_{RST} < V_{DD} < V_{PFW}$. Power-fail warning detected. Turn on regulator and crystal. Crystal warmup time, t_{XTAL_RDY} . Exit stop mode.
D	On	Off	Off	Yes	Application enters stop mode. $V_{DD} > V_{RST}$. CPU in stop mode.
E	On (Periodically)	Off	Off	Yes	$V_{POR} < V_{DD} < V_{RST}$. Power-fail detected. CPU goes into reset. Power-fail monitor turns on periodically.
F	Off	Off	Off	—	$V_{DD} < V_{POR}$. Device held in reset. No operation allowed.

Low-Voltage Microcontroller with Infrared Module

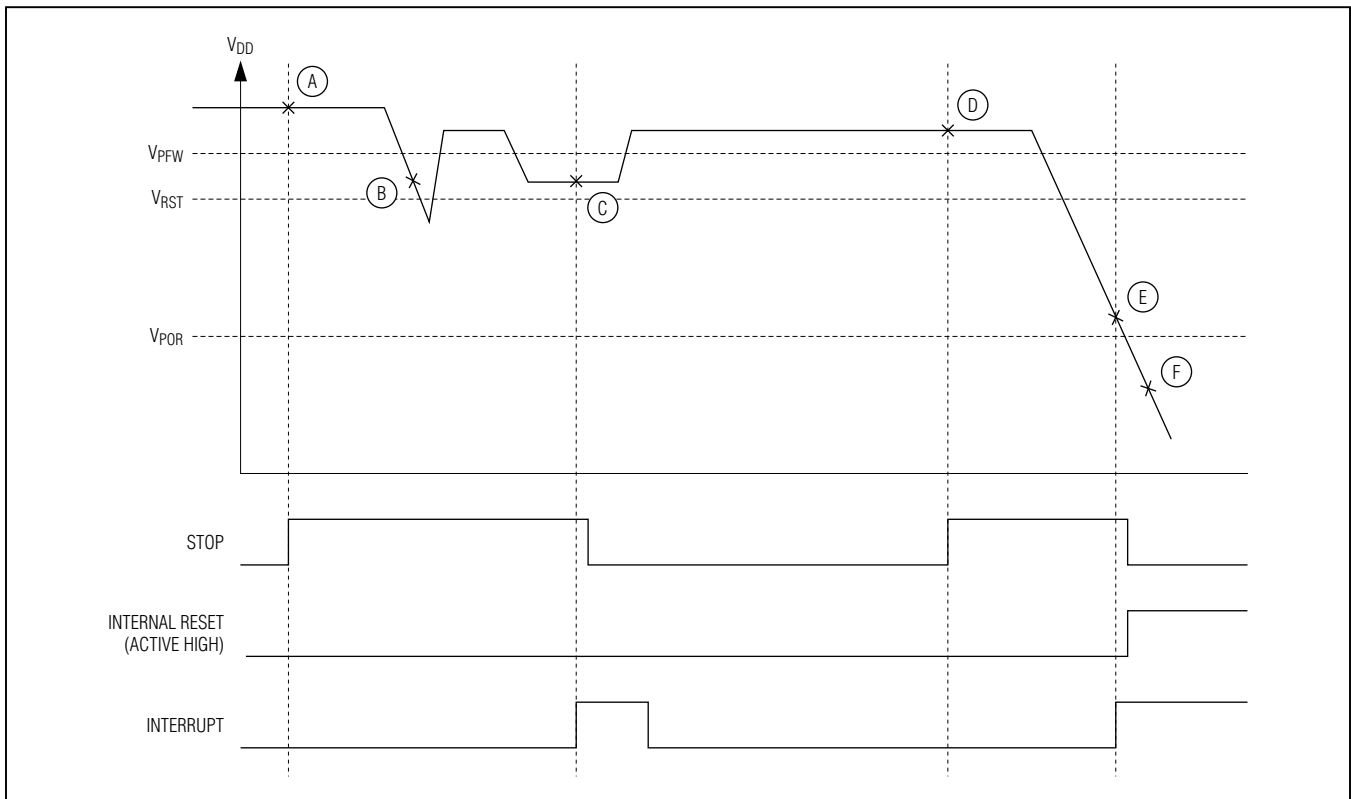

Figure 13. Stop Mode Power-Fail Detection States with Power-Fail Monitor Disabled

Table 7. Stop Mode Power-Fail Detection States with Power-Fail Monitor Disabled

STATE	POWER-FAIL	INTERNAL REGULATOR	CRYSTAL OSCILLATOR	SRAM RETENTION	COMMENTS
A	Off	Off	Off	Yes	Application enters stop mode. $V_{DD} > V_{RST}$. CPU in stop mode.
B	Off	Off	Off	Yes	$V_{DD} < V_{PFW}$. Power-fail not detected because power-fail monitor is disabled.
C	On	On	On	Yes	$V_{RST} < V_{DD} < V_{PFW}$. An interrupt occurs that causes the CPU to exit stop mode. Power-fail monitor is turned on, detects a power-fail warning, and sets the power-fail interrupt flag. Turn on regulator and crystal. Crystal warmup time, t_{XTAL_RDY} . On stop mode exit, CPU vectors to the higher priority of power-fail and the interrupt that causes stop mode exit.

Low-Voltage Microcontroller with Infrared Module

Table 7. Stop Mode Power-Fail Detection States with Power-Fail Monitor Disabled (continued)

STATE	POWER-FAIL	INTERNAL REGULATOR	CRYSTAL OSCILLATOR	SRAM RETENTION	COMMENTS
D	Off	Off	Off	Yes	Application enters stop mode. $V_{DD} > V_{RST}$. CPU in stop mode.
E	On (Periodically)	Off	Off	Yes	$V_{POR} < V_{DD} < V_{RST}$. An interrupt occurs that causes the CPU to exit stop mode. Power-fail monitor is turned on, detects a power-fail, and puts CPU in reset. Power-fail monitor is turned on periodically.
F	Off	Off	Off	—	$V_{DD} < V_{POR}$. Device held in reset. No operation allowed.

Applications Information

The low-power, high-performance RISC architecture of this device makes it an excellent fit for many portable or battery-powered applications. It is ideally suited for applications such as universal remote controls that require the cost-effective integration of IR transmit/receive capability.

Grounds and Bypassing

Careful PCB layout significantly minimizes system-level digital noise that could interact with the microcontroller or peripheral components. The use of multilayer boards is essential to allow the use of dedicated power planes. The area under any digital components should be a continuous ground plane if possible. Keep bypass capacitor leads short for best noise rejection and place the capacitors as close to the leads of the devices as possible.

CMOS design guidelines for any semiconductor require that no pin be taken above V_{DD} or below GND. Violation of this guideline can result in a hard failure (damage to the silicon inside the device) or a soft failure (unintentional modification of memory contents). Voltage spikes above or below the device's absolute maximum ratings can potentially cause a devastating IC latchup.

Microcontrollers commonly experience negative voltage spikes through either their power pins or general-

purpose I/O pins. Negative voltage spikes on power pins are especially problematic as they directly couple to the internal power buses. Devices such as keypads can conduct electrostatic discharges directly into the microcontroller and seriously damage the device. System designers must protect components against these transients that can corrupt system memory.

Additional Documentation

Designers must have the following documents to fully use all the features of this device. This data sheet contains pin descriptions, feature overviews, and electrical specifications. Errata sheets contain deviations from published specifications. User guides contain detailed descriptions of device features and peripherals from a programming perspective. The following documents can be downloaded from www.maximintegrated.com/microcontrollers:

- This MAXQ305 data sheet, which contains electrical/timing specifications, package information, and pin descriptions.
- The MAXQ305 revision-specific errata sheet (www.maximintegrated.com/errata)
- The MAXQ305 User's Guide, which contains detailed information and programming guidelines for core features and peripherals.

MAXQ305

Low-Voltage Microcontroller with Infrared Module

Development and Technical Support

Maxim and third-party suppliers provide a variety of highly versatile, affordably priced development tools, including the following:

- Compilers
- Integrated Development Environments (IDEs)

- Serial-to-JTAG and USB-to-JTAG interface boards for programming and debugging (for microcontrollers with rewriteable memory)

A partial list of development tool vendors can be found at www.maximintegrated.com/MAXQ_tools.

Technical support is available at <https://support.maximintegrated.com/micro>.

Ordering Information/Selector Guide

PART	TEMP RANGE	PIN-PACKAGE	OPERATING VOLTAGE (V)	PROGRAM MEMORY (KB)	DATA MEMORY (KB)	GPIO
MAXQ305J-0000+	0°C to +70°C	44 TQFN-EP*	0.9 to 3.6	80 flash	2	32
MAXQ305X-0000+**	0°C to +70°C	Bare die	0.9 to 3.6	80 flash	2	32

Note: Contact factory for information about masked ROM devices.

+Denotes a lead(Pb)-free/RoHS-compliant package.

*EP = Exposed pad.

**Contact factory for availability.

Package Information

For the latest package outline information and land patterns (footprints), go to www.maximintegrated.com/packages. Note that a "+", "#", or "-" in the package code indicates RoHS status only. Package drawings may show a different suffix character, but the drawing pertains to the package regardless of RoHS status.

PACKAGE TYPE	PACKAGE CODE	OUTLINE NO.	LAND PATTERN NO.
44 TQFN-EP	T4477+2	21-0144	90-0127

MAXQ305

Low-Voltage Microcontroller with Infrared Module

Revision History

REVISION NUMBER	REVISION DATE	DESCRIPTION	PAGES CHANGED
0	10/12	Initial release	—



Maxim Integrated cannot assume responsibility for use of any circuitry other than circuitry entirely embodied in a Maxim Integrated product. No circuit patent licenses are implied. Maxim Integrated reserves the right to change the circuitry and specifications without notice at any time. The parametric values (min and max limits) shown in the Electrical Characteristics table are guaranteed. Other parametric values quoted in this data sheet are provided for guidance.

Maxim Integrated 160 Rio Robles, San Jose, CA 95134 USA 1-408-601-1000

29