

May.1.2023 Copyright 2023 HIROSE ELECTRIC CO., LTD. All Rights Reserved.
In case of consideration for using Automotive equipment / device which demand high reliability, kindly contact our sales window correspondents.

COUNT	DESCRIPTION OF REVISIONS	BY	CHKD	DATE	COUNT	DESCRIPTION OF REVISIONS	BY	CHKD	DATE
△				..	△				..
△				..	△				..
△				..	△				..

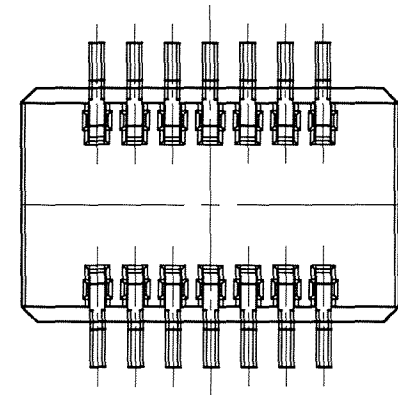
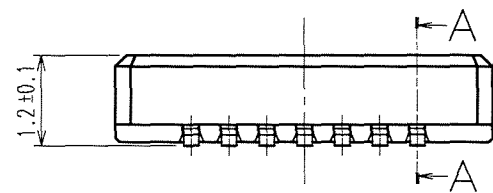
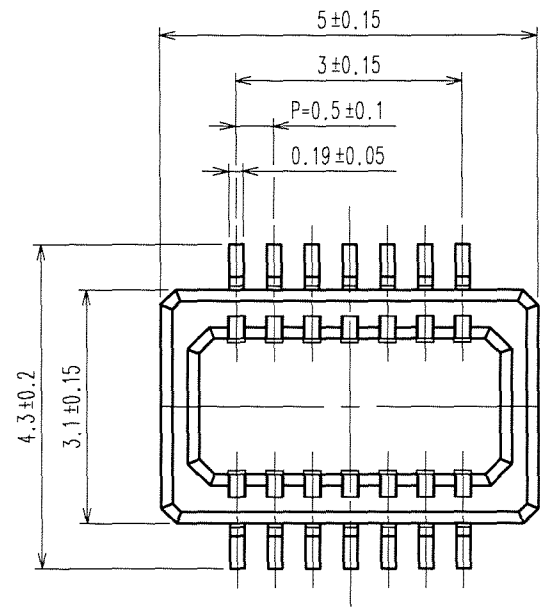
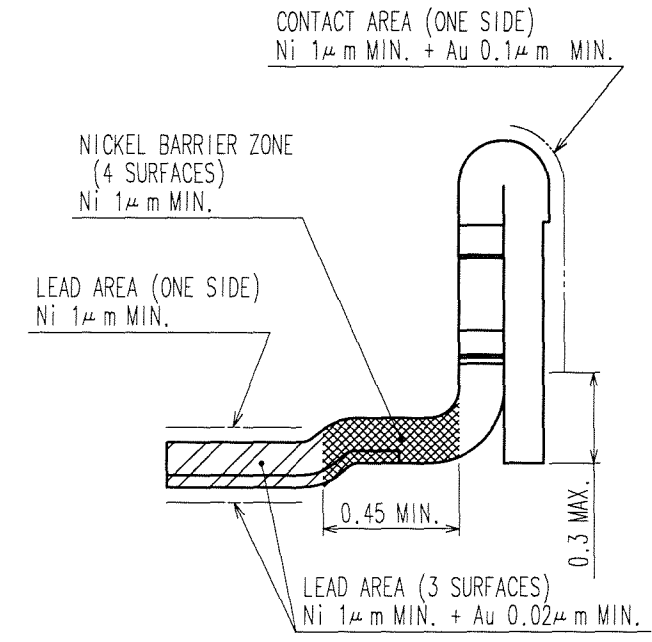
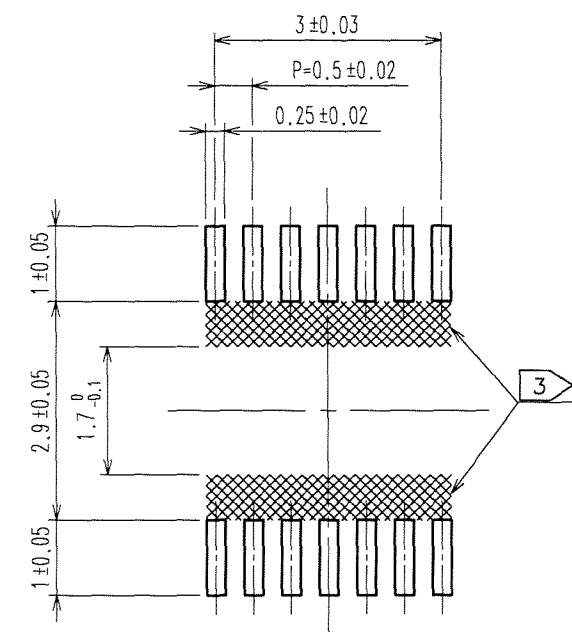

Fig.1 : RECOMMENDED PATTERN

Fig.2 : PLATING SPECIFICATION (40:1)



OTHERS : Ni 1µm MIN. + Au FLASH

Fig.4 : MATING VIEW

HRS DRAWING FOR REFERENCE

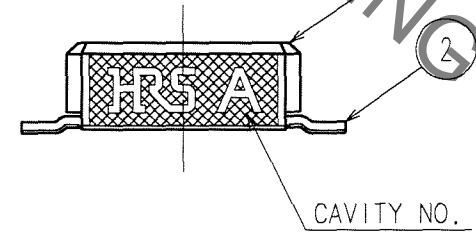
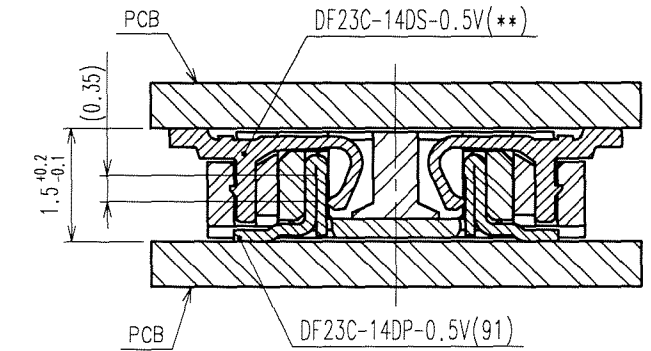
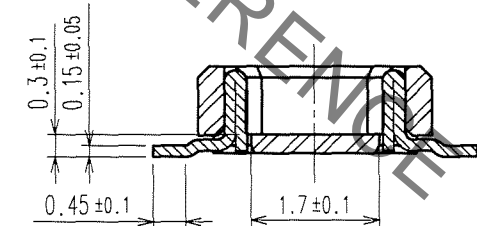

Fig.3 : A-A CROSS SECTION VIEW



- NOTES 1 LEAD CO-PLANARITY SHALL BE 0.1mm MAX.
 2 REFER TO Fig.2
 3 WHEN A PART MARKED WITH [Hatched Box] HAS A PATTERN BUT NO RESIST ON IT, TAKE CARE TO PREVENT THE CONNECTOR FROM TOUCHING IT.
 4 THE DIMENSIONS IN PARENTHESES ARE FOR REFERENCE.

2	PHOSPHOR BRONZE	2	4	POLYESTER	CLEAR(COVER TAPE)
1	LCP	BLACK,UL94V-0	3	PS	CLEAR(EMBOSSED CARRIER TAPE)
NO.	MATERIAL	FINISH, REMARKS	NO.	MATERIAL	FINISH, REMARKS
CODE NO. (OLD)		DRAWN	DESIGNED	CHECKED	APPROVED
		A.Aoyagi	J. Yamamoto	T. Niigaki	M. Kobayashi
		'07. 6. 6	07. 6. 6	07.06.07	07.06.07
DRAWING NO.		PART NO.			
EDC3-163722-03		DF23C-14DP-0.5V(91)			
SCALE		CODE NO.			
10 : 1		CL688-0800-5-91		1/2	
UNITS		HIROSE ELECTRIC CO., LTD			
mm					

TO

May.1.2023 Copyright 2023 HIROSE ELECTRIC CO., LTD. All Rights Reserved.
In case of consideration for using Automotive equipment / device which demand high reliability, kindly contact our sales window correspondents.

Fig.6 :STYLE AND DIMENSIONS OF REEL(FREE)

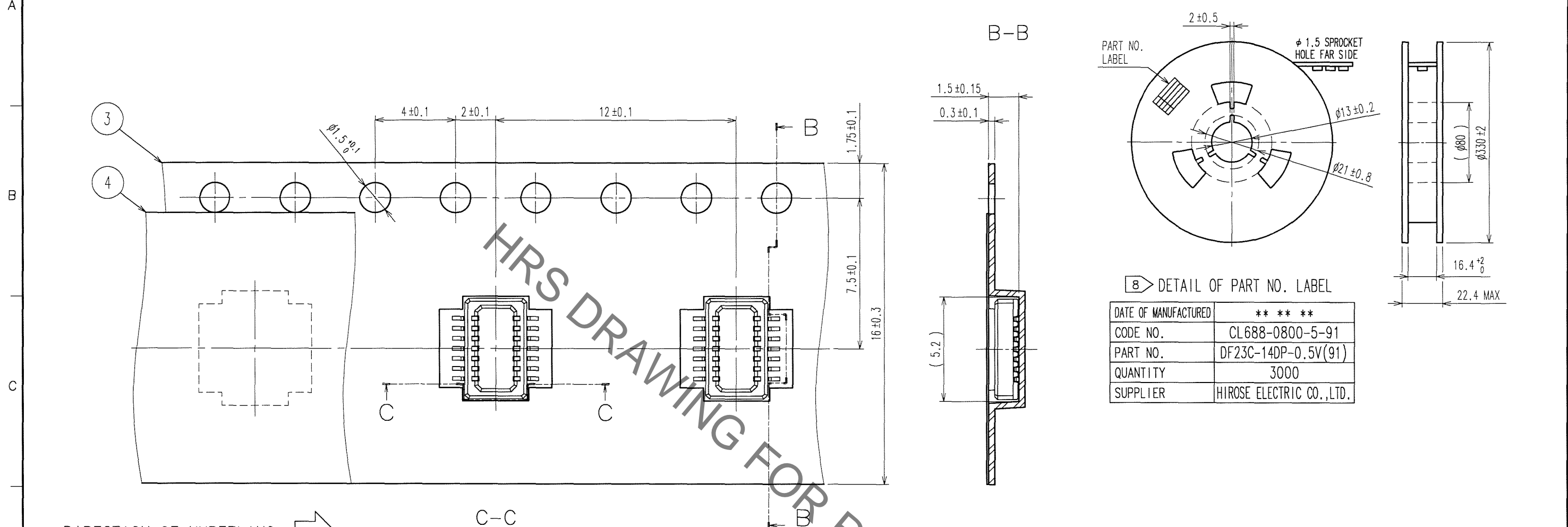

DETAIL OF PART NO. LABEL

DATE OF MANUFACTURED	** * * *
CODE NO.	CL688-0800-5-91
PART NO.	DF23C-14DP-0.5V(91)
QUANTITY	3000
SUPPLIER	HIROSE ELECTRIC CO., LTD.

Fig.7 : PACKAGING SPECIFICATION (FREE)

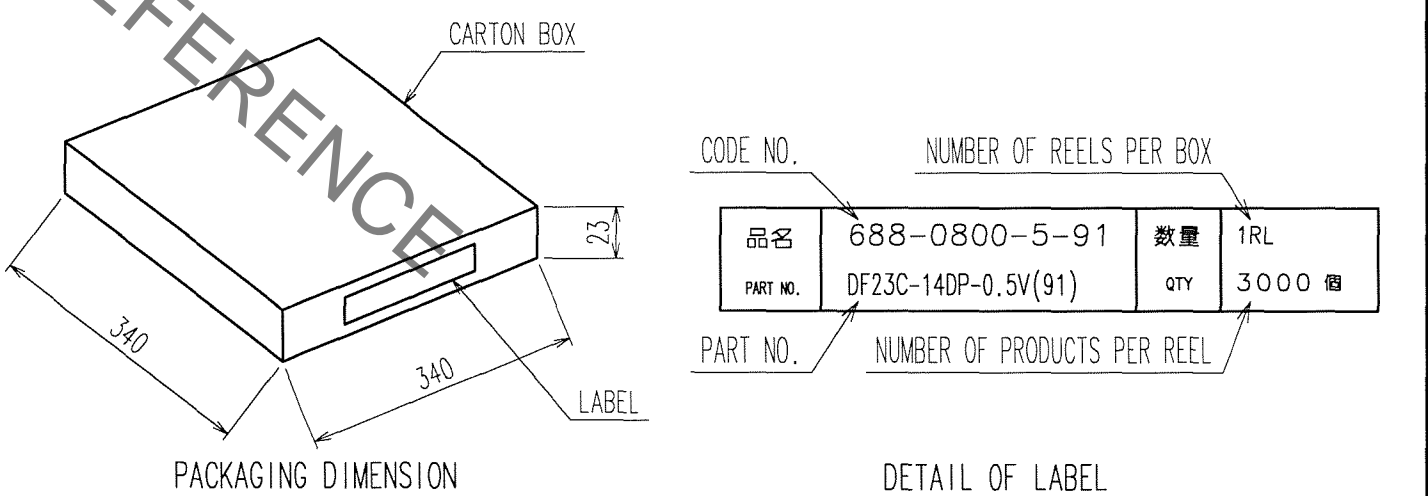

DIRECTION OF UNREELING →

Fig.5 : TAPING (FREE)

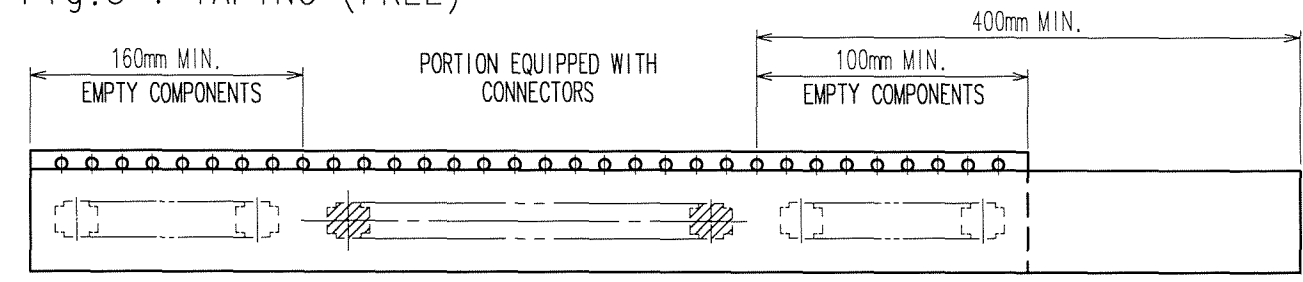

- NOTES
- PER REEL 3000 CONNECTORS
 - THE DIMENSIONS IN PARENTHESES ARE FOR REFERENCE.
 - REFER TO JIS C 0806 (PACKAGING OF COMPONENTS FOR AUTOMATIC HANDLING)
 - DETAIL OF PART NO. LABEL IS WRITTEN IN JAPANESE.

CODE NO. (OLD)	DRAWN	DESIGNED	CHECKED	APPROVED	RELEASED
	A. Aoyagi	J. Yamamoto	T. Miyajima	M. Ishikawa	
	'07. 6. 6	'07. 6. 6	'07. 06. 07	'07. 06. 07	
SCALE	DRAWING NO.	PART NO.			
5 : 1	EDC3-163722-03	DF23C-14DP-0.5V(91)			
UNITS	HIROSE ELECTRIC CO., LTD	CODE NO.			
mm		CL688-0800-5-91			

TO