



EVQ6528-V-00A

5V to 60V, H-Bridge Gate Driver Evaluation Board, AEC-Q100 Qualified

DESCRIPTION

The EVQ6528-V-00A is an evaluation board designed for the MPQ6528, an H-bridge gate driver.

The EVQ6528-V-00A operates from a supply voltage of up to 60V. It is configured to drive two half-bridges consisting of four N-channel power MOSFETs. The driving control signals are generated by the external controller (e.g. MCU or FPGA).

The MPQ6528 is available in a QFN-28 (4mmx5mm) package.

ELECTRICAL SPECIFICATIONS

Parameter	Symbol	Value	Units
Input voltage	V_{IN}	5 to 60	V
OC_REF voltage	V_{OC_REF}	0.125 to 2.4	V
VCC voltage	V_{CC}	3.3 or 5	V

FEATURES

- Wide 5V to 60V Input Voltage Range
- Configurable OCP Threshold
- Supports 100% Duty Cycle Operation
- Over-Current Protection (OCP), Over-Temperature Protection (OTP)
- Fault Indication Output
- Available in a QFN-28 (4mmx5mm) Package
- AEC-Q100 Grade 1

APPLICATIONS

- DC Brush Motors
- Automotive Actuators
- Power Converters
- Gate Openers

All MPS parts are lead-free, halogen-free, and adhere to the RoHS directive. For MPS green status, please visit the MPS website under Quality Assurance. "MPS", the MPS logo, and "Simple, Easy Solutions" are trademarks of Monolithic Power Systems, Inc. or its subsidiaries.

EVQ6528-V-00A EVALUATION BOARD

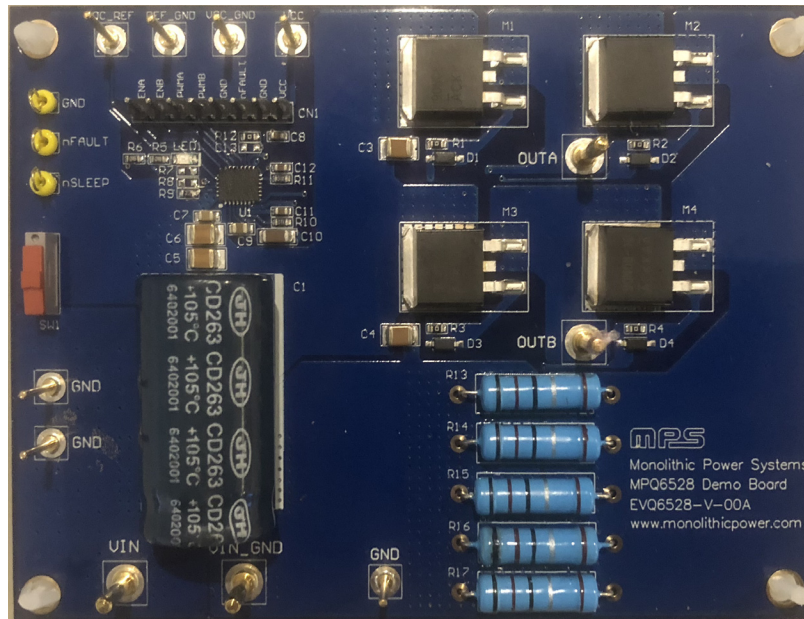

LxW (10.3cmx7.8cm)

Board Number	MPS IC Number
EVQ6528-V-00A	MPQ6528GV

QUICK START GUIDE

1. Attach the input voltage ($5V \leq V_{IN} \leq 60V$) to the VIN connector, and attach input ground to the GND connector.
2. Attach the VCC voltage (3.3V or 5V) to the VCC connector, then switch SW1 to the bottom side (position 1) to enable the chip.
3. To set the over-current protection (OCP) threshold, attach the OC_REF voltage ($0.125V \leq V_{OC_REF} \leq 2.4V$) to the OC_REF connector.
4. Attach the driving control signals generated by the external controller to the CN1 connector.

EVALUATION BOARD SCHEMATIC

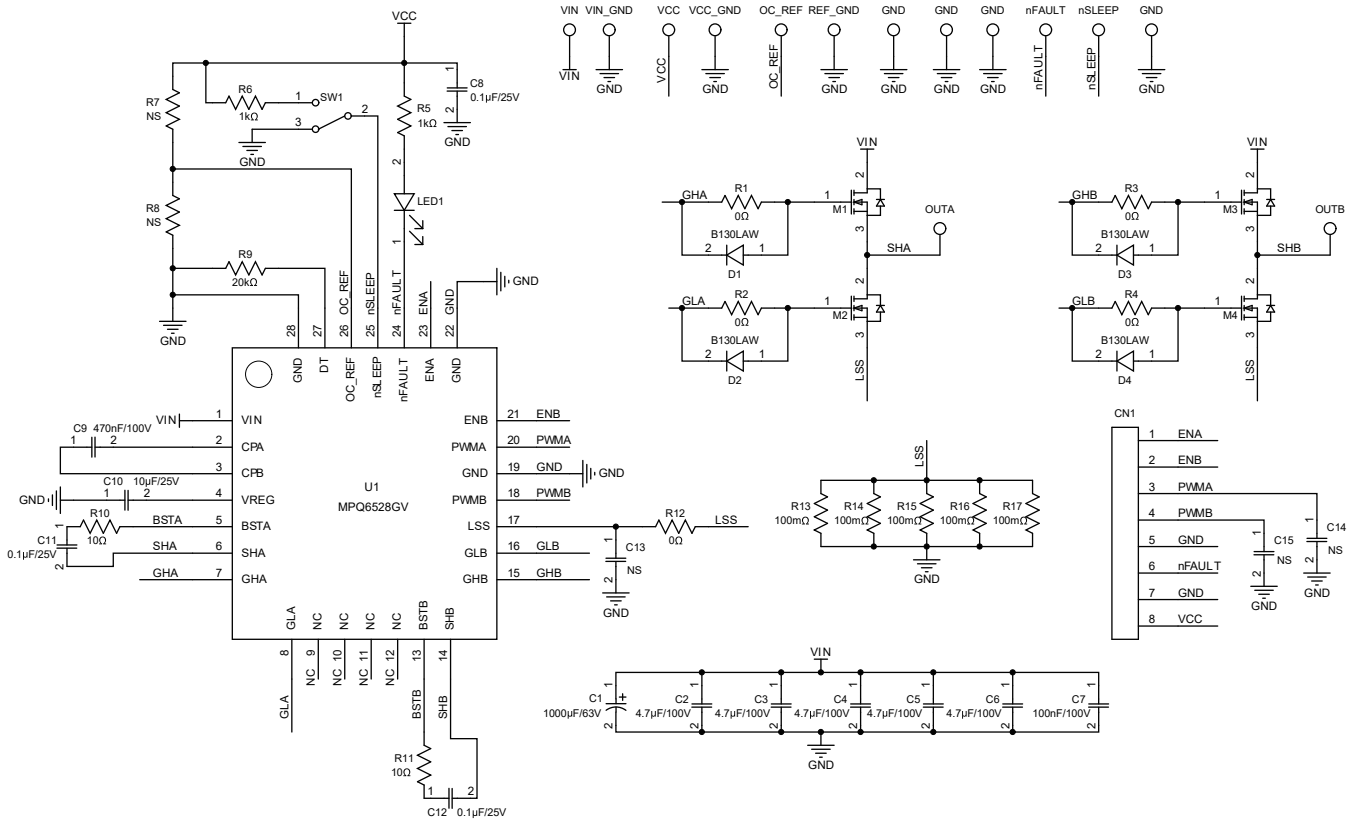

Figure 1: Evaluation Board Schematic

EVQ6528-V-00A BILL OF MATERIALS

Qty	Ref	Value	Description	Package	Manufacturer	Manufacturer P/N
1	C1	1000 μ F	Electrolytic capacitor, 63V	DIP	Jianghai	CD263-63V1000
5	C2, C3, C4, C5, C6	4.7 μ F	Ceramic capacitor, 100V, X7S	1210	Murata	GRJ32DC72A475KE11L
1	C7	100nF	Ceramic capacitor, 100V, X7R	0805	Murata	GRM21BR72A104KAC4L
3	C8, C11, C12	100nF	Ceramic capacitor, 25V, X8R	0603	Murata	GCM188R91E104KA37D
1	C9	470nF	Ceramic capacitor, 100V, X7R	0805	Murata	GRM21BR72A474KA73L
1	C10	10 μ F	Ceramic capacitor, 25V, X5R	1206	TDK	C3216X5R1E106K
3	C13, C14, C15	NS				
5	R1, R2, R3, R4, R12	0 Ω	Film resistor, 1%	0603	Yageo	RC0603FR-070RL
2	R5, R6	1k Ω	Film resistor, 1%	0603	Yageo	RC0603FR-071KL
2	R7, R8	NS				
1	R9	20k Ω	Film resistor, 1%	0603	Yageo	RC0603FR-0720KL
2	R10, R11	10 Ω	Film resistor, 1%	0603	Yageo	RC0603FR-0710RL
5	R13, R14, R15, R16, R17	100m Ω	Resistor, 1%, 2W	DIP	Any	
4	D1, D2, D3, D4	30V, 1A	Schottky diode	SOD-123	Diodes	B130LAW
4	M1, M2, M3, M4	80V, 90A	N-channel MOSFET, 80V, 90A, $Q_G = 60nC$, 11m Ω when $V_{GS} = 10V$	TO-263	Analog Power	AM90N08-10B-T1-PE
1	LED1	Red	LED	0805	Baihong	BL-HUE35A-AV-TRB
1	SW1	SPDT	Button	DIP	Wurth	450301014042
1	CN1	8-bits/ 2.54mm	Connector	DIP	Any	
4	VIN, VIN_GND, OUTA, OUTB	$\Phi = 2mm$	Connector	DIP	Any	
7	VCC, VCC_GND, OC_REF, REF_GND, GND_GND, GND	$\Phi = 1mm$	Connector	DIP	Any	
3	nFAULT, nSLEEP, GND	Yellow	Test point	DIP	Any	
1	U1	MPQ6528	60V, H-bridge gate driver	QFN-28 (4mmx5mm)	MPS	MPQ6528GV

PCB LAYOUT

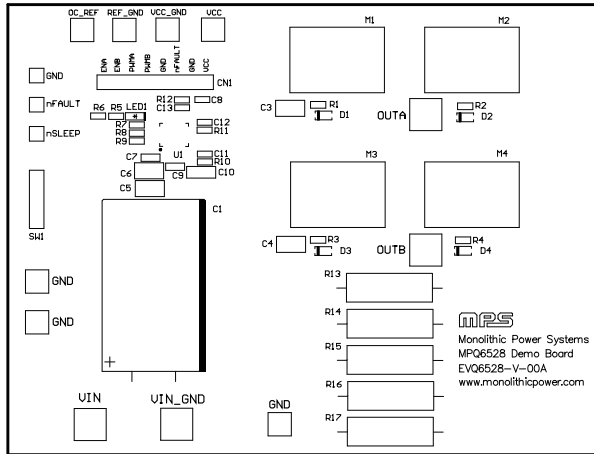

Figure 2: Top Silk Layer

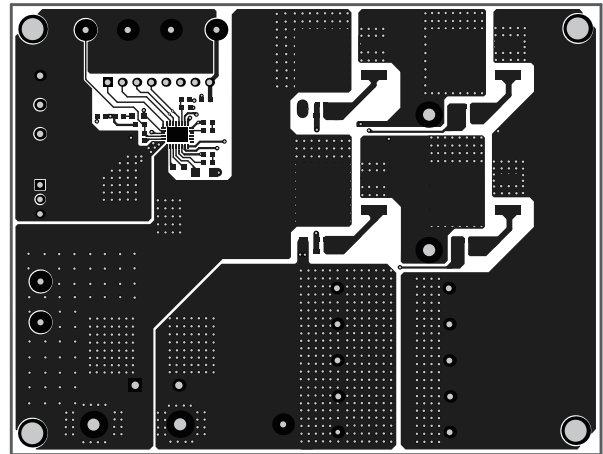

Figure 3: Top Layer

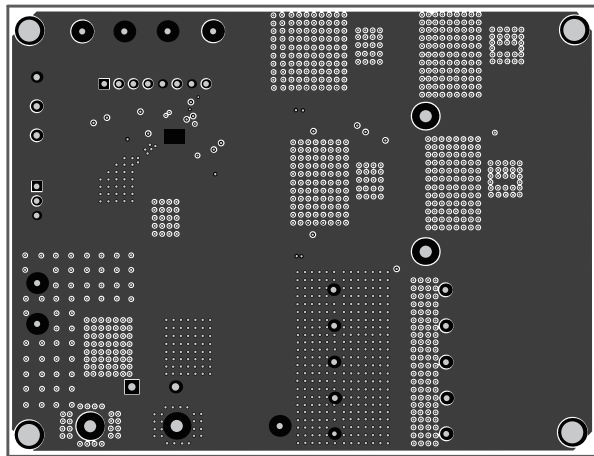

Figure 4: Inner Layer 1

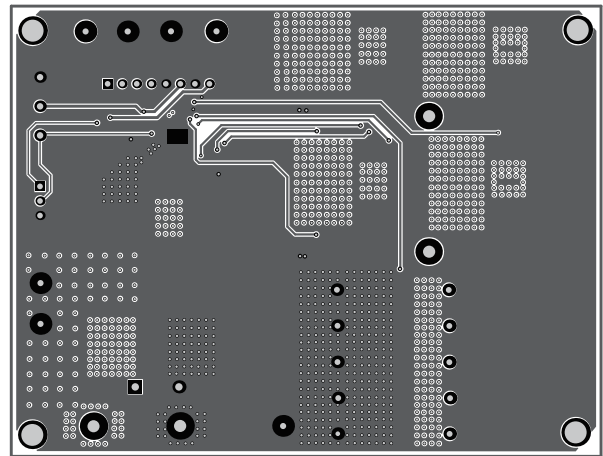

Figure 5: Inner Layer 2

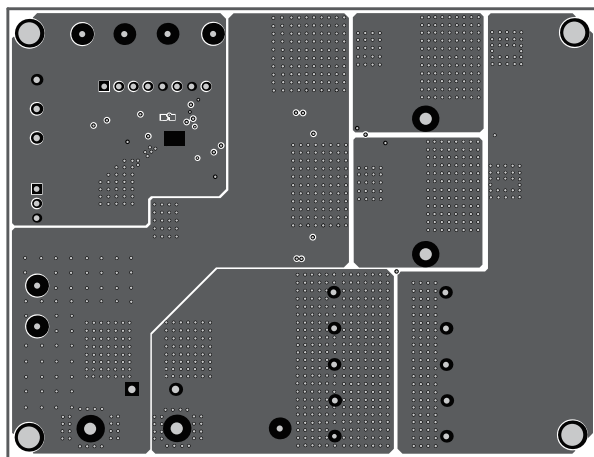

Figure 6: Bottom Layer

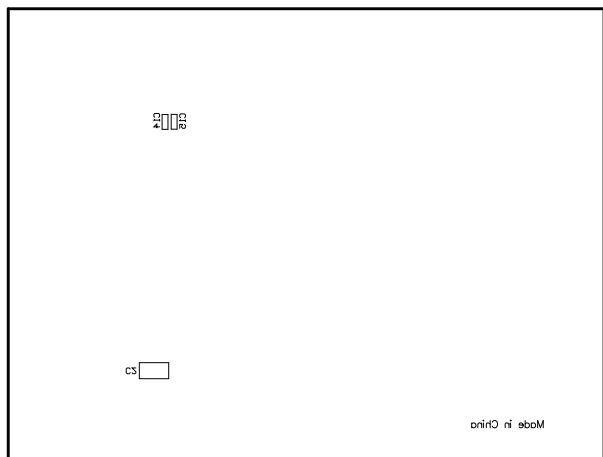

Figure 7: Bottom Silk Layer



REVISION HISTORY

Revision #	Revision Date	Description	Pages Updated
1.0	4/15/2021	Initial Release	-

Notice: The information in this document is subject to change without notice. Please contact MPS for current specifications. Users should warrant and guarantee that third-party Intellectual Property rights are not infringed upon when integrating MPS products into any application. MPS will not assume any legal responsibility for any said applications.