

May.1.2023 Copyright 2023 HIROSE ELECTRIC CO., LTD. All Rights Reserved.
In case of consideration for using Automotive equipment / device which demand high reliability, kindly contact our sales window correspondents.

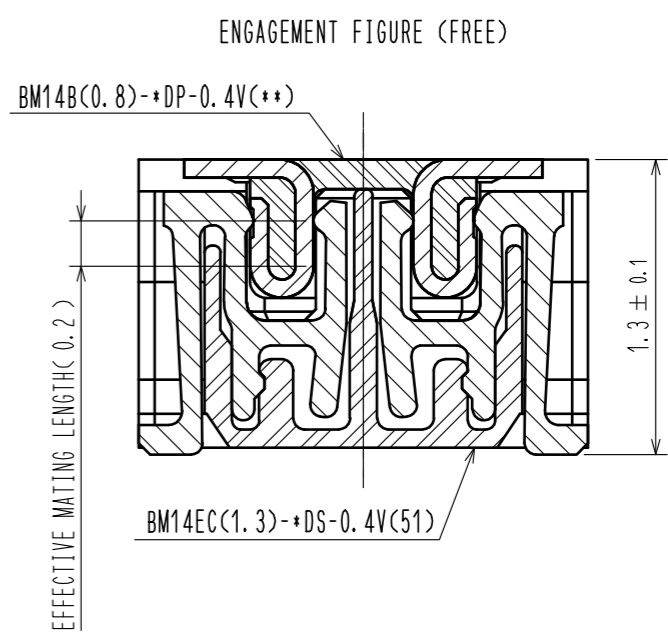
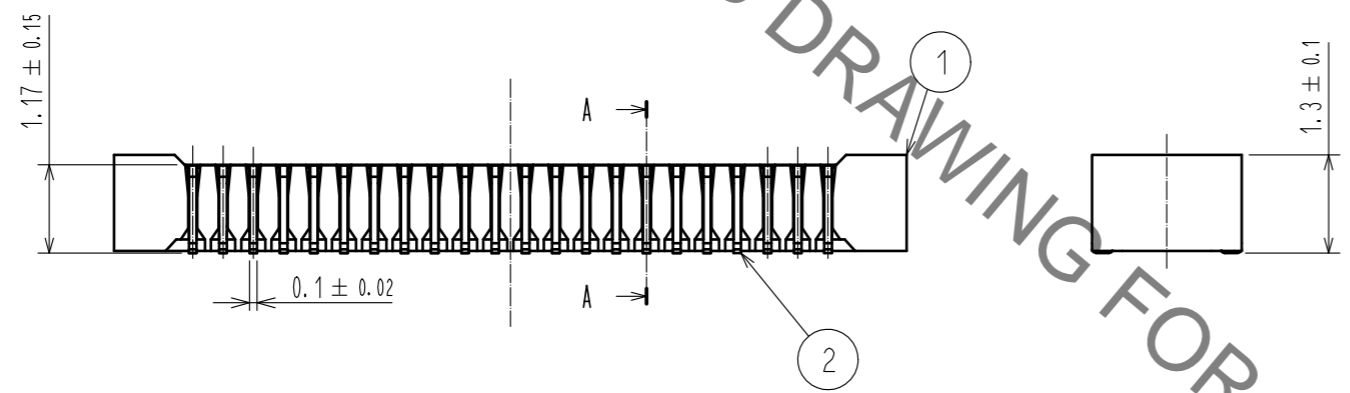
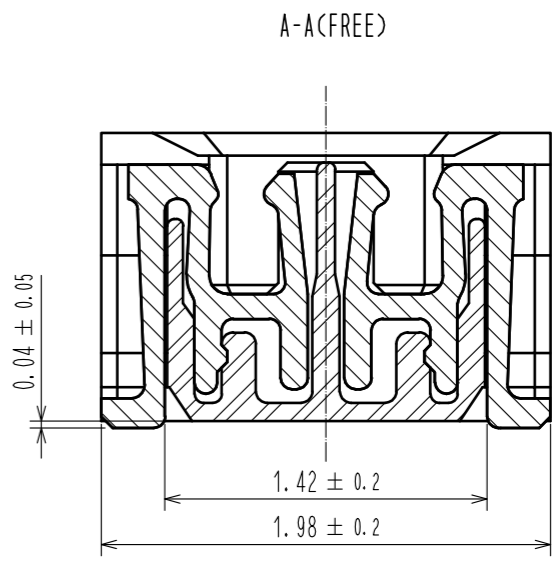
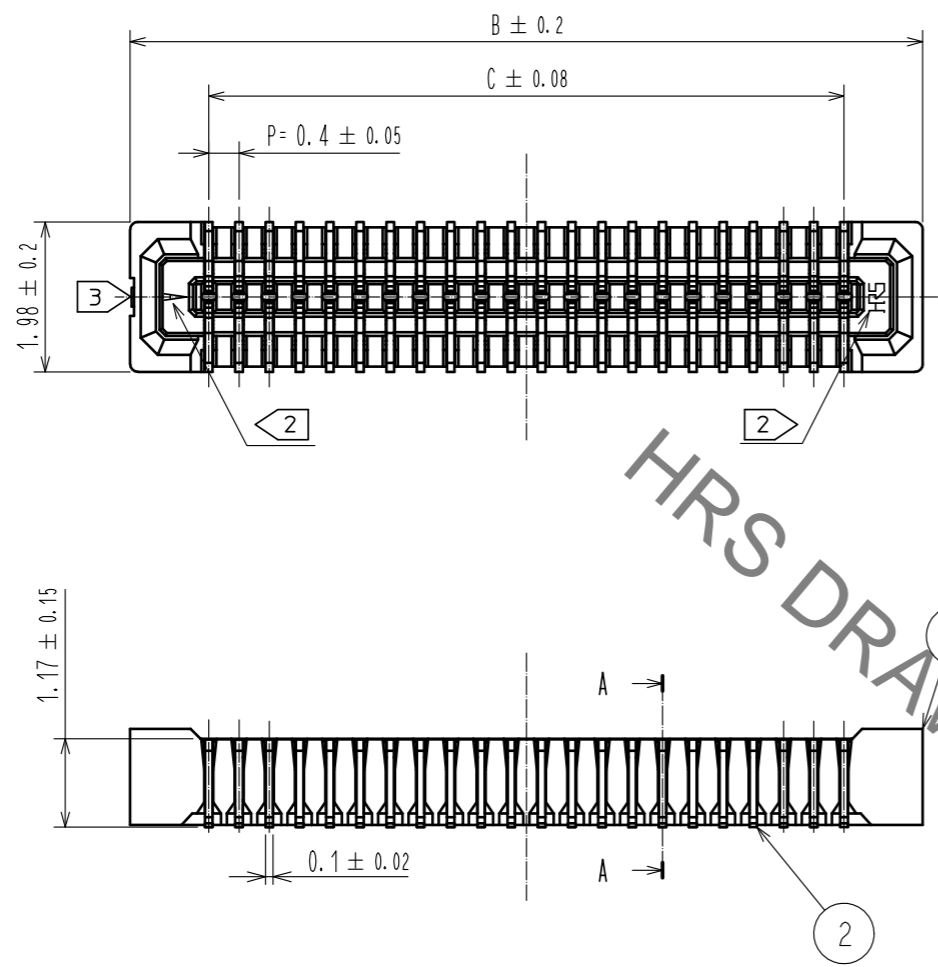

NOTE) 1 . ALL LEAD CO-PLANARITY SHALL BE 0.08mm MAX
 2 HRS MARK AND CAV NO. ARE INDICATED IN APPROX POSITION SHOWN.
 3 GATE POSITION IS INDICATED IN APPROX POSITION SHOWN.

PART No.	CODE No.	B	C
BM14EC(1.3)-14DS-0.4V(51)	-	4.48	2.4
BM14EC(1.3)-16DS-0.4V(51)	CL684-8180-0-51	4.88	2.8
BM14EC(1.3)-24DS-0.4V(51)	-	6.48	4.4
BM14EC(1.3)-28DS-0.4V(51)	-	7.28	5.2
BM14EC(1.3)-34DS-0.4V(51)	-	8.48	6.4
BM14EC(1.3)-44DS-0.4V(51)	CL684-8155-3-51	10.48	8.4
BM14EC(1.3)-54DS-0.4V(51)	CL684-8157-9-51	12.48	10.4
BM14EC(1.3)-64DS-0.4V(51)	-	14.48	12.4

NO.	MATERIAL	FINISH	REMARKS	NO.	MATERIAL	FINISH	REMARKS
2	PHOSPHOR BRONZE		CONTACT AREA : GOLD 0.05 μm MIN. SMT LEAD : GOLD 0.05 μm MIN. UNDERPLATING : NICKEL 1 μm MIN.	6	PS		CLEAR (REINFORCEMENT COLLAR)
				5	PS		BLACK (PLASTIC REEL)
				4	POLYESTER		CLEAR (COVER TAPE)
1	LCP		UL94 V-0, BLACK	3	PS		CLEAR (EMBOSSED CARRIER TAPE)

UNITS	SCALE	COUNT	DESCRIPTION OF REVISIONS	DESIGNED	CHECKED	DATE
mm	10:1	3	DIS-H-00002669	NY.YAMASHIRO	TS.MIYAZAKI	17.03.07

APPROVED	CHECKED	DESIGNED	DRAWN	DRAWING NO.	PART NO.	CODE NO.
KH.IKEDA	TS.MIYAZAKI	TR.YUNOKI	YN.SAKAMOTO	EDC3-327823-01	BM14EC(1.3)-*DS-0.4V(51)	CL684
10.04.23	10.04.23	10.04.23	10.04.22			

May.1.2023 Copyright 2023 HIROSE ELECTRIC CO., LTD. All Rights Reserved.
In case of consideration for using Automotive equipment / device which demand high reliability, kindly contact our sales window correspondents.

◆ RECOMMENDED PCB LAYOUT

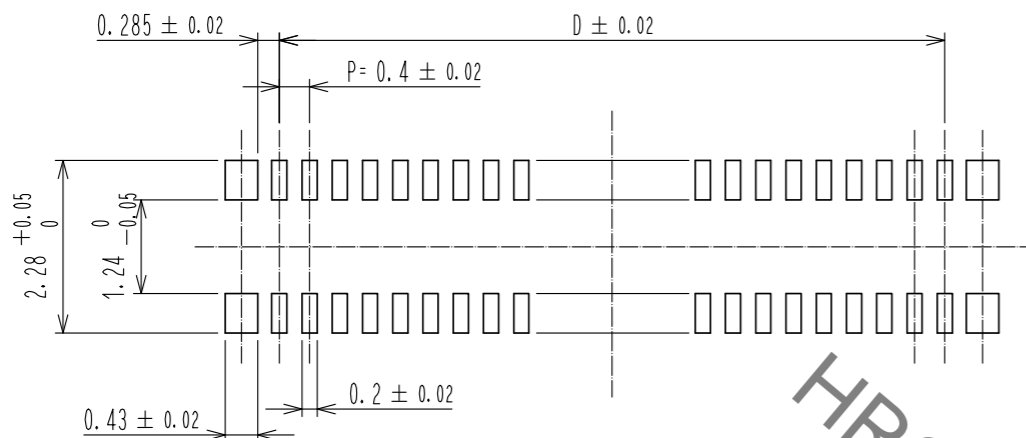

◆ RECOMMENDED METAL MASK DIMENSIONS

METAL MASK THICKNESS : 100 μm

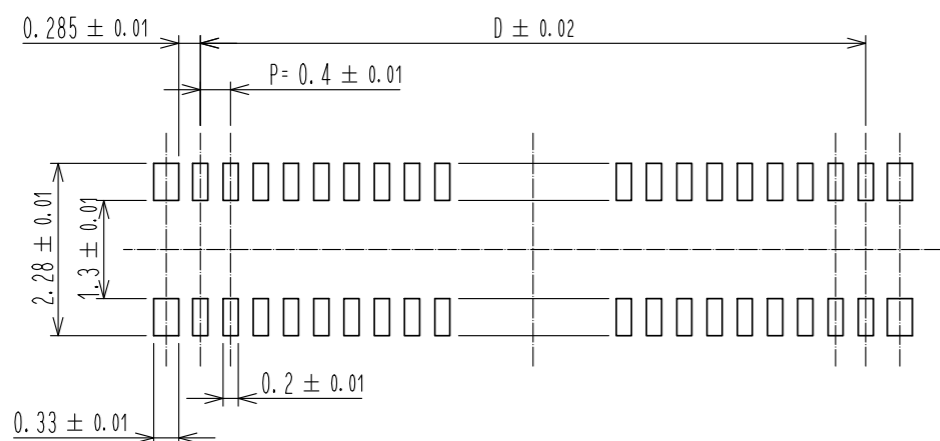

PART No.	D
BM14EC(1.3)-14DS-0.4V(51)	1.6
BM14EC(1.3)-16DS-0.4V(51)	2.0
BM14EC(1.3)-24DS-0.4V(51)	3.6
BM14EC(1.3)-28DS-0.4V(51)	4.4
BM14EC(1.3)-34DS-0.4V(51)	5.6
BM14EC(1.3)-44DS-0.4V(51)	7.6
BM14EC(1.3)-54DS-0.4V(51)	9.6
BM14EC(1.3)-64DS-0.4V(51)	11.6

4 RECOMMENDED REFLOW TEMPERATURE PROFILE USING LEAD-FREE SOLDER PASTE.

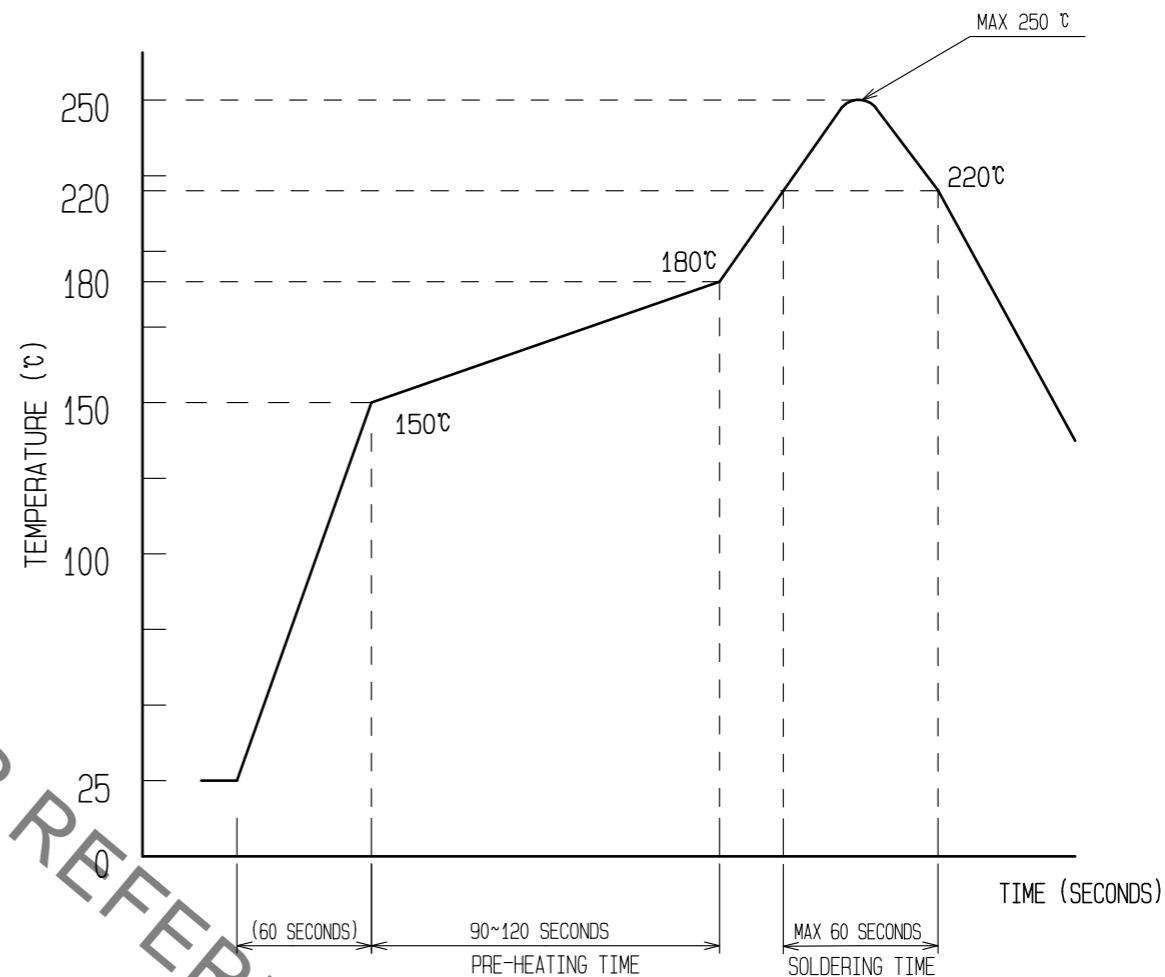

REFLOW METHOD: IR REFLOW
 NUMBER OF REFLOW CYCLES: 2 CYCLES MAX.
 1) REFLOW TIME
 DURATION ABOVE 220°C, 60 SEC. MAX.
 (PEAK TEMPERATURE: 250°C MAX)
 2) PRE-HEAT TIME
 PRE-HEAT TEMPERATURE(MIN): 150°C
 PRE-HEAT TEMPERATURE(MAX): 180°C
 PRE-HEAT TIME: 90-120 sec.

4 THIS TEMPERATURE PROFILE IS PER THE CONDITIONS SHOWN ABOVE. ADDITIONAL FACTORS, SUCH AS SOLDER PASTE TYPE, PCB SIZE AND OTHER MOUNTED COMPONENTS COULD AFFECT THE PROFILE, THEREFORE, A THOROUGH EVALUATION OF MOUNTING CONDITION IS REQUIRED PRIOR TO PRODUCTION. TEMPERATURE IS MEASURED AT CONTACT LEAD.

HRS	DRAWING NO.	EDC3-327823-01
	PART NO.	BM14EC(1.3)-*DS-0.4V(51)
	CODE NO.	CL684
		2/3

May.1.2023 Copyright 2023 HIROSE ELECTRIC CO., LTD. All Rights Reserved.
In case of consideration for using Automotive equipment / device which demand high reliability, kindly contact our sales window correspondents.

EMBOSSED CARRIER TAPE PACKAGING (5:1)

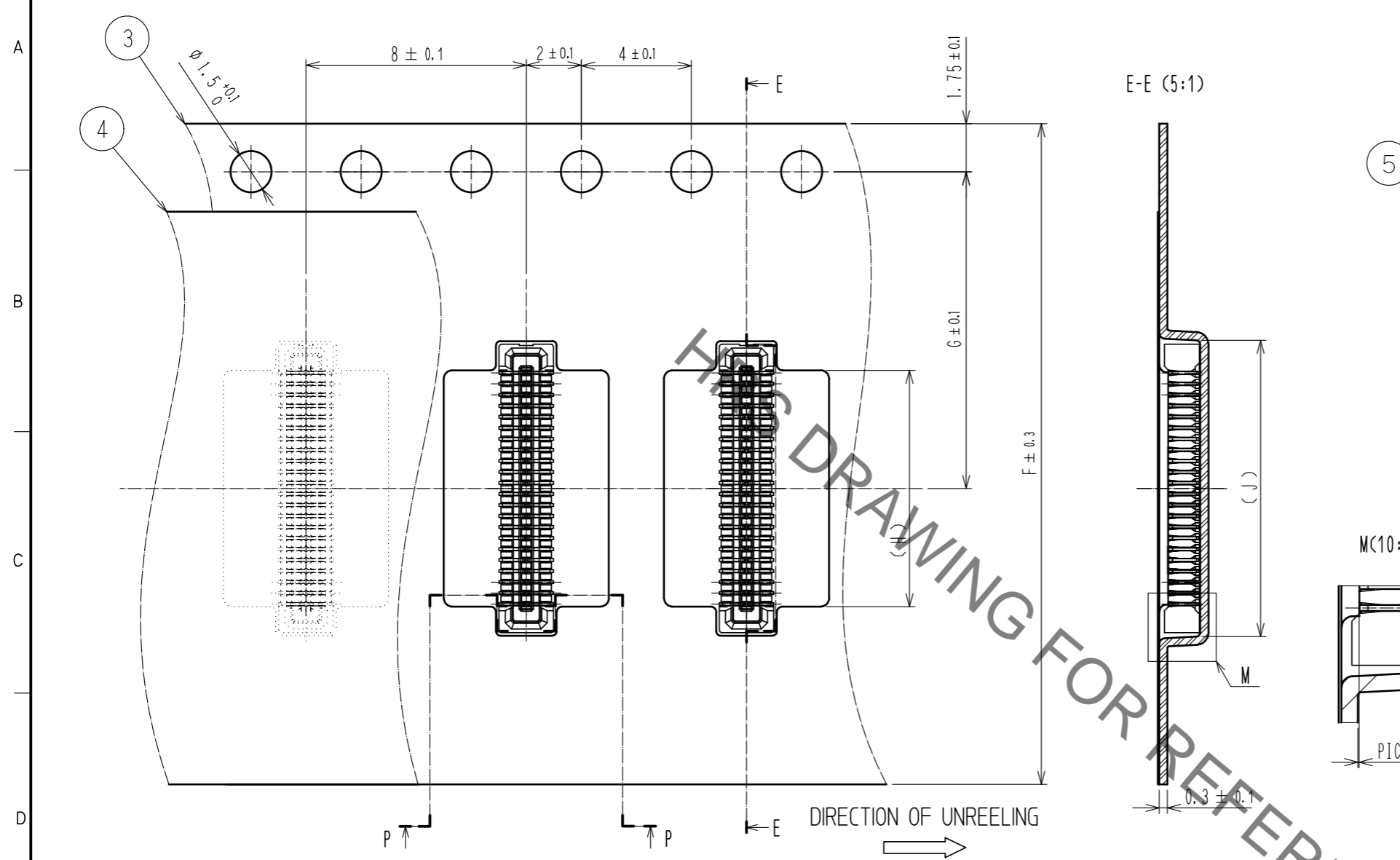

STYLE AND DIMENTION OF REEL (FREE)

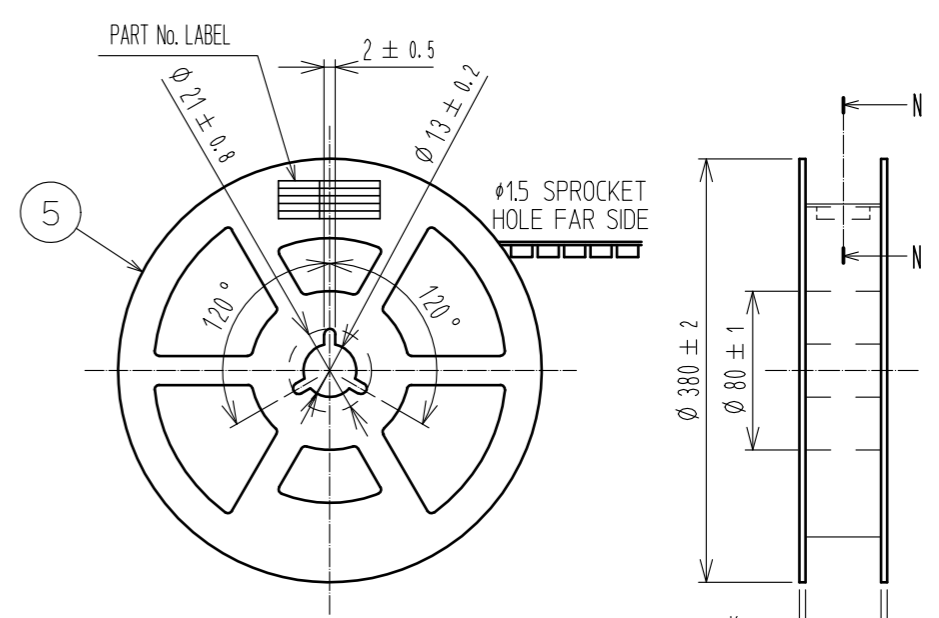

DETAIL OF PART No. LABEL

M(10:1)

PICK UP AREA(0.02)

SUPPLIER	
QUANTITY	
PART No.	
CODE No.	
DATE OF MANUFACTURED	
製造年月日	** ** *
製品コード	CL684-****-51
製品名	BM14EC(1.3)-*DS-0.4V(51)
数量	5,000
納入者	ヒロセ電機(株)

N-N (FREE)

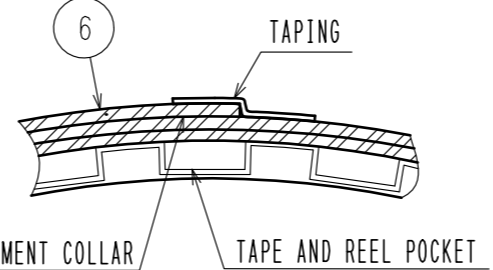

P-P(5:1)

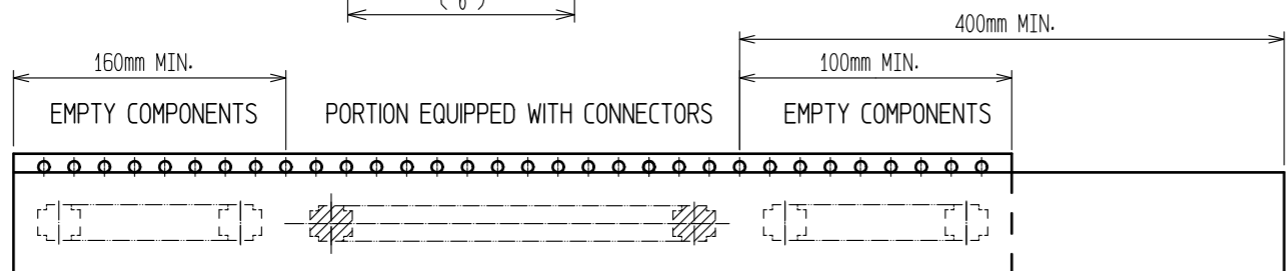
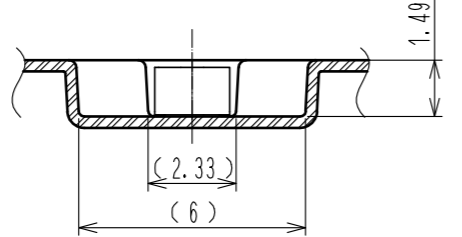

PART No.	F	G	H	J	K	L
BM14EC(1.3)-14DS-0.4V(51)	16	7.5	2.58	4.7	17.5	21.5
BM14EC(1.3)-16DS-0.4V(51)	16	7.5	2.98	5.1	17.5	21.5
BM14EC(1.3)-24DS-0.4V(51)	16	7.5	4.58	6.7	17.5	21.5
BM14EC(1.3)-28DS-0.4V(51)	16	7.5	5.38	7.5	17.5	21.5
BM14EC(1.3)-34DS-0.4V(51)	24	11.5	6.58	8.7	25.5	29.5
BM14EC(1.3)-44DS-0.4V(51)	24	11.5	8.58	10.7	25.5	29.5
BM14EC(1.3)-54DS-0.4V(51)	24	11.5	10.58	12.7	25.5	29.5
BM14EC(1.3)-64DS-0.4V(51)	24	11.5	12.58	14.7	25.5	29.5

- 5. PER REEL 5000 CONNECTORS.
- 6. THE DIMENSIONS IN PARENTHESES ARE FOR REFERENCE.
- 7 REFER TO JIS C 0806 AND IEC 60286-3 (PACKAGING OF COMPONENTS FOR AUTOMATIC HANDING)
- 8 <DELETED>
- 9 AFTER PACKAGING, ROLL 2 METERS OF THE REINFORCEMENT COLLAR TO OUTER CIRCUMFERENCE OF TAPE AND REEL POCKET, AND TAPE DOWN AT THE END THE COLLAR.

HRS	DRAWING NO.	EDC3-327823-01
	PART NO.	BM14EC(1.3)-*DS-0.4V(51)
	CODE NO.	CL684