

Order Number
200222-0100



Application Tooling Specification

FEATURES

- This extractor tool is for the removal of crimped terminals from housing series 160014, 160027, 160028 and 160029

SCOPE

Products: stAK50h Connector System.

Housing Series No.	Housing Order No.				Terminal Series No.	Terminal Order No.				
160014	160014-0001	160014-0002	160014-0003	160014-0004	200096	200096-3101	200096-3161	200096-3201	200096-3261	
160027	160027-0001	160027-0002	160027-0003	160027-0004						
	160027-0005	160027-0006	160027-0007	160027-0008						
160028	160028-0001	160028-0002	160028-0003	160028-0004						
	160028-0005	160028-0006	160028-0007	160028-0008						
160029	160029-0001	160029-0002	160029-0003	160029-0004						

Description: This one-piece extraction tool is 30.0 mm (1.20 in.) long by 6.00mm (.240 in.) wide.

OPERATION

When removing a damaged crimped terminal from the stAK50h housing, follow the steps below:

1. Position the extractor tool blade into the small rectangular slot (in line with the terminal to be removed) in the front face of the housing. See Figure 1.

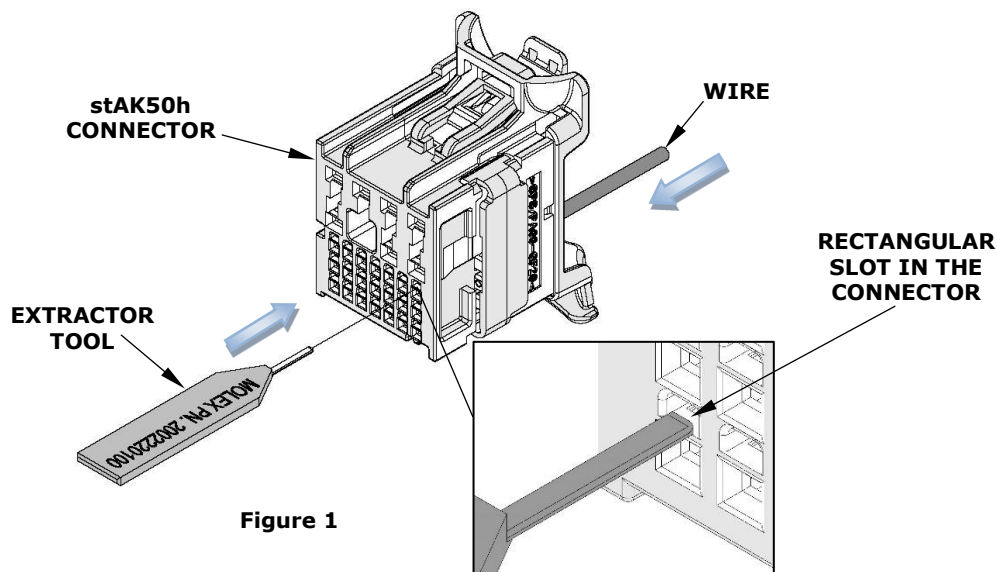

Figure 1

Extractor Tool for stAK50h Crimp Terminals

2. Push the crimped wire forward in the arrow direction before using the extractor tool.
3. Continue to push the extractor tool into the square slot until it clicks or comes to a stop.
4. This should separate the latch from the terminal. Do not force the extractor tool any further; otherwise, it may damage the housing.
5. Holding the extractor tool against the housing, gently pull the crimped wire out of the connector. See Figure 2.

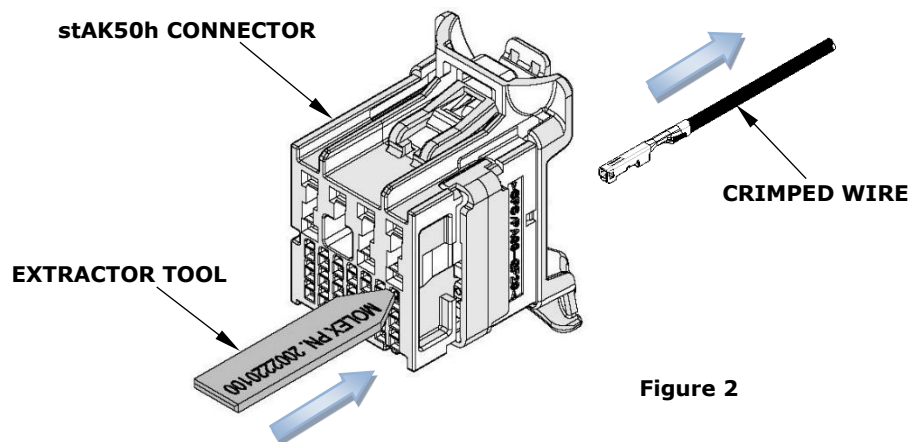

Figure 2

CAUTION: This extractor tool should be used to extract the terminal only. Using it for unintended purposes may cause injury or damage to parts. Be careful not to deform the end of the terminal.

CAUTION: Molex specifications are valid only when used with Molex terminals, applicators and tooling.

Application Tooling Support

Phone: (402) 458-TOOL (8665)

E-Mail: applicationtooling@molex.com

Website: www.molex.com/applicationtooling

Molex is a registered trademark of Molex, LLC in the United States of America and may be registered in other countries; all other trademarks listed herein belong to their respective owners.